

SPECIFICATIONS:

MODEL NUMBER: 8090-911-250
PUMP DESIGN: Positive Displacement 3 Chamber Diaphragm Pump
CAM: 2.0 Degree
MOTOR: Permanent Magnet, P/N 11-160-00, Thermally Protected
VOLTAGE: 230 VAC Nominal
PRESSURE SWITCH: None
LIQUID TEMPERATURE: 180 Degrees Fahrenheit (82 Degrees Centigrade) Max.
PRIME: Self-Priming Up To 8.0 Ft. Vertical,
 Max. Inlet Pressure 30 PSI (2.1 Bar)
PORTS: 3/8"-18 NPT Female
MATERIAL OF CONSTRUCTION:
 PLASTICS- Nylon
 VALVES- EPDM
 DIAPHRAGM- Santoprene
 FASTENERS- Zinc Plated Steel
NET WEIGHT: 3.85 Lbs (1.75 Kg)
DUTY CYCLE: Intermittent (See Temperature Rise Chart)
TYPICAL APPLICATIONS: Soil Extraction
BYPASS: 65 PSI Max.
APPROVALS: VDE Approved

DIMENSIONS:

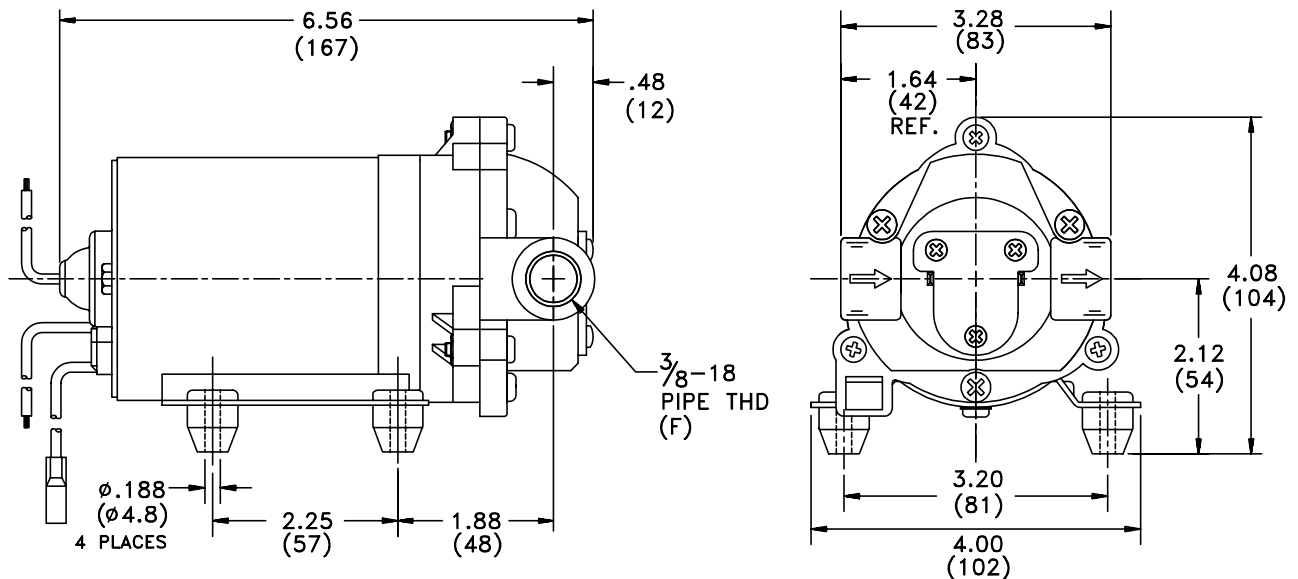

TEMPERATURE RISE

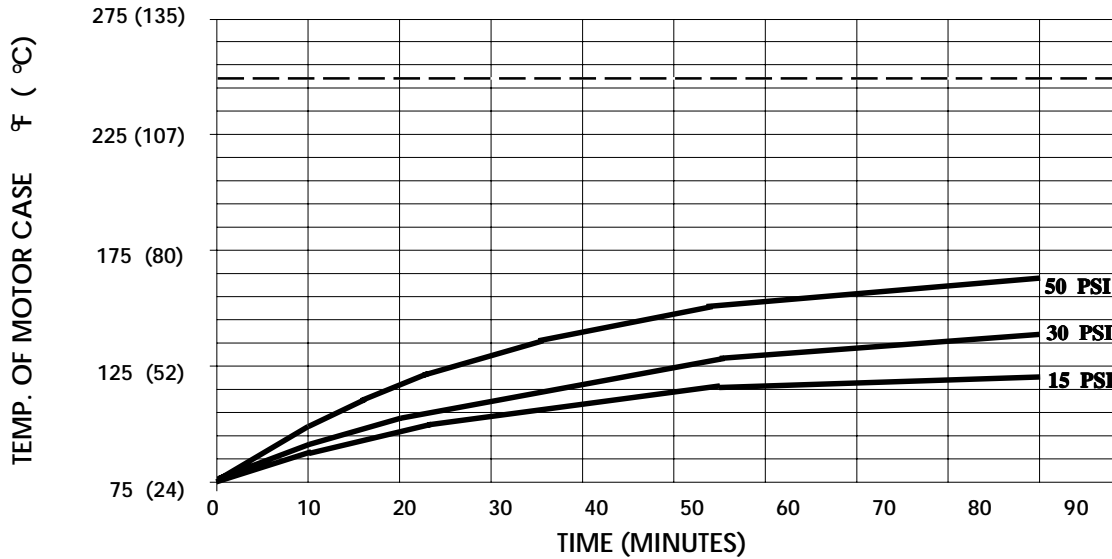

THIS GRAPH IS FOR USE AS A DESIGN GUIDE. IT IS BASED ON RUNNING CONTINUOUSLY WITH AN AMBIENT TEMPERATURE OF 75°F IN STILL AIR. THE THERMAL BREAKER WILL OPEN WHEN THE CASE TEMPERATURE REACHES 250°F.

[----- TRIP POINT OF THERMAL PROTECTOR]

TYPICAL PERFORMANCE

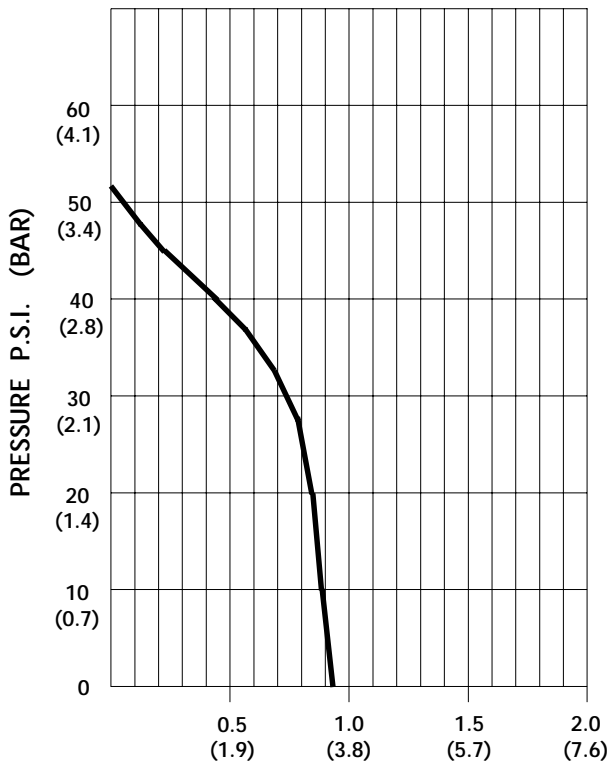

PRESSURE (PSI)	FLOW (GPM/LIT)	RPM MIN/MAX	CURRENT (AMPS)	VOLTAGE (VOLTS)
OPEN	0.92/3.5	2405/2480	0.11	230VAC
10	0.87/3.3	2280/2405	0.12	"
20	0.85/3.2	2120/2290	0.14	"
30	0.76/2.9	2030/2190	0.16	"
40	0.43/1.6	1995/2115	0.18	"

FLOW - GALLONS PER MINUTE (LITERS PER MINUTE)

-SPECIFICATIONS SUBJECT TO CHANGE WITHOUT NOTICE.

-ALL DATA BASED ON TESTING WITH WATER AT AMBIENT TEMPERATURE.