

SPECIFICATIONS:

MODEL NUMBER: 8005-952-220

PUMP DESIGN: Positive Displacement 3 Chamber Diaphragm Pump

CAM: 2.5 Degree

MOTOR: Permanent Magnet, P/N 11-147-10, Thermally Protected

VOLTAGE: 24 VDC Nominal

PRESSURE SWITCH: None

LIQUID TEMPERATURE: 170 Degrees Fahrenheit (77 Degrees Centigrade) Max.

PRIME: Self-Priming Up To 5 Ft. Vertical,
Max. Inlet Pressure 30 PSI (2.1 Bar)

PORTS: 3/8"-18 NPT Female

MATERIAL OF CONSTRUCTION:

PLASTICS- Nylon

VALVES- EPDM

DIAPHRAGM- Santoprene

FASTENERS- Zinc Plated Steel

NET WEIGHT: 4.8 Lbs (2.18 Kg)

DUTY CYCLE: Intermittent (See Temperature Rise Chart)

APPROVALS: NSF Listed

TYPICAL APPLICATIONS: R.O. Booster Pump

BYPASS: 60 PSI Springs

DIMENSIONS:

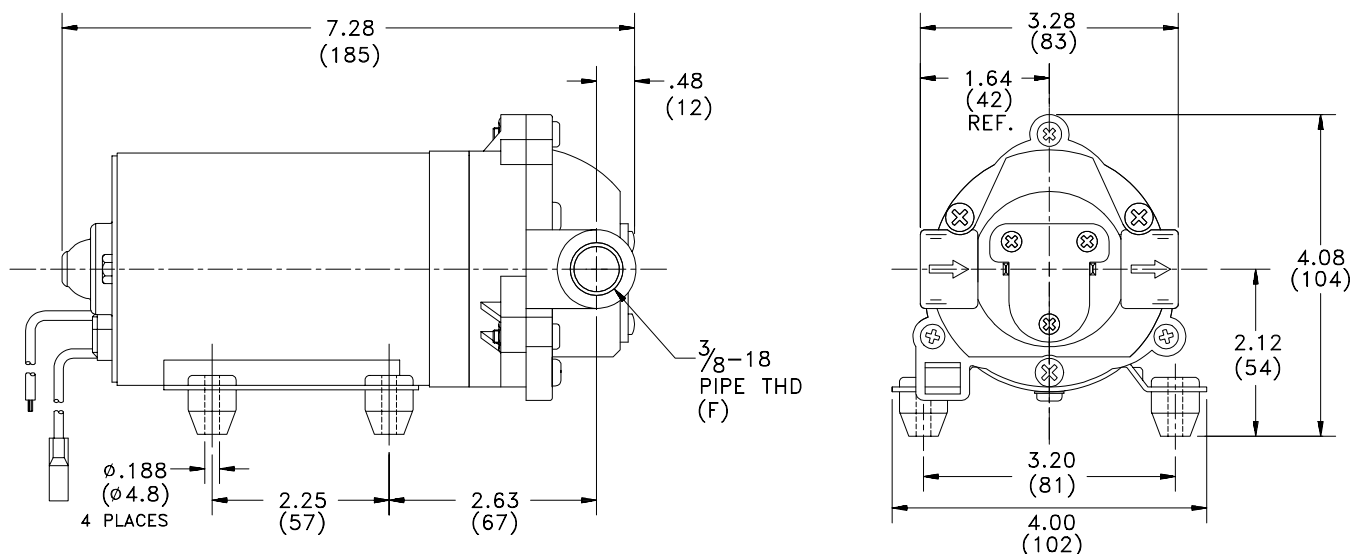

TEMPERATURE RISE

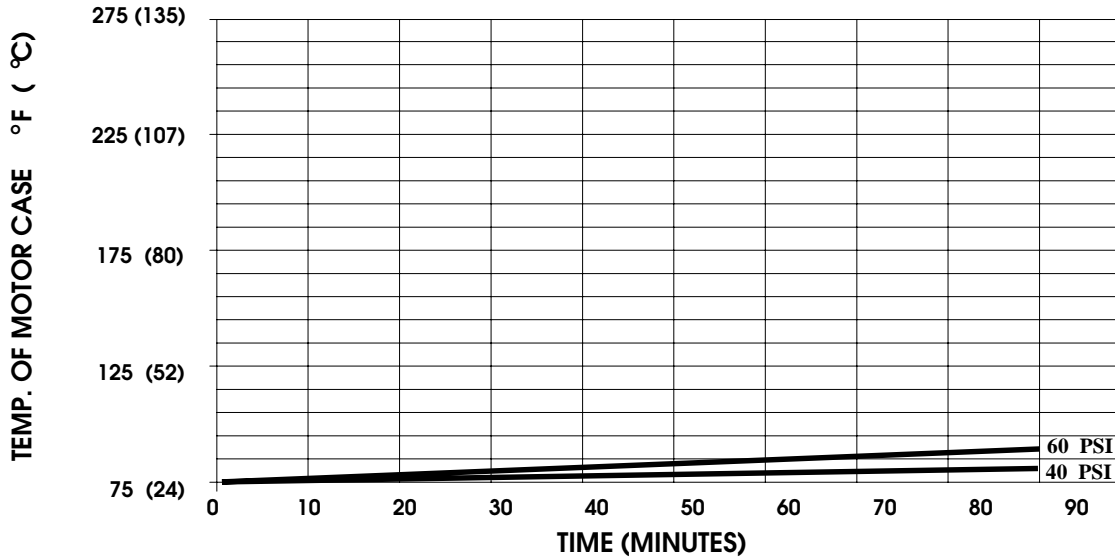

THIS GRAPH IS FOR USE AS A DESIGN GUIDE. IT IS BASED ON RUNNING CONTINUOUSLY WITH AN AMBIENT TEMPERATURE OF 70° F IN STILL AIR.

TYPICAL PERFORMANCE

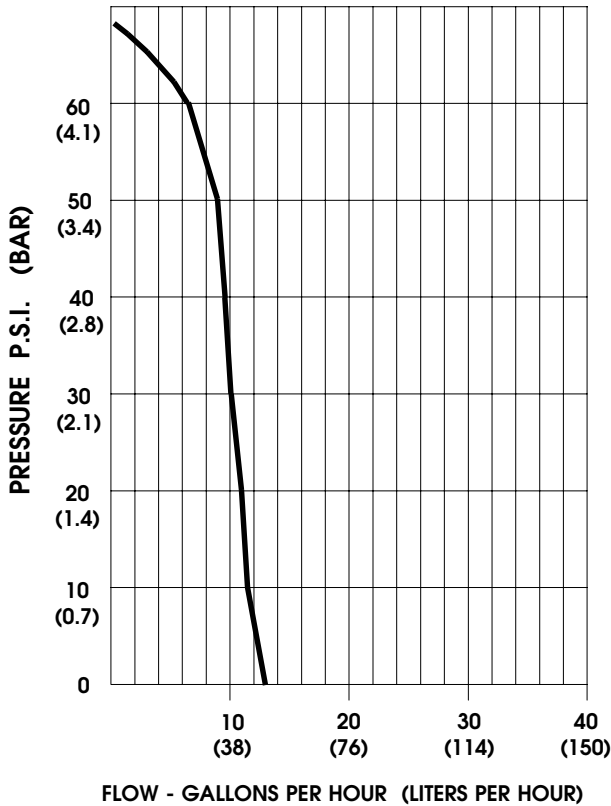

PRESSURE (PSI)	FLOW (GPH/LIT)	RPM MIN/MAX	CURRENT (AMPS)	VOLTAGE (VOLTS)
OPEN	13.0/49.2	410/425	0.14	24 VDC
10	11.5/43.5	410/420	0.17	"
20	10.9/41.2	390/400	0.22	"
30	10.1/38.2	375/380	0.27	"
40	9.6/36.3	365/370	0.32	"
50	8.9/33.7	345/355	0.36	"
60	6.6/25.0	330/340	0.41	"
70	0.0/0.0	320/330	0.44	"

-SPECIFICATIONS SUBJECT TO CHANGE WITHOUT NOTICE.

-ALL DATA BASED ON TESTING WITH WATER.