

SPECIFICATIONS:

MODEL NUMBER: 8005-951-260
PUMP DESIGN: Positive Displacement 3 Chamber Diaphragm Pump
CAM: 2.0 Degree
MOTOR: Permanent Magnet, P/N 11-196-00
VOLTAGE: 24VDC Nominal
PRESSURE SWITCH: None
LIQUID TEMPERATURE: 180 Degrees Fahrenheit (82 Degrees Centigrade) Max.
PORTS: 3/8"-18 NPT Female
MATERIAL OF CONSTRUCTION:
 PLASTICS- Nylon
 VALVES- EPDM
 DIAPHRAGM- Santoprene
 FASTENERS- Stainless Steel
NET WEIGHT: 5.6 Lbs (2.5 Kg)
DUTY CYCLE: Continuous (See Temperature Rise Chart)
APPROVALS: NSF Listed
TYPICAL APPLICATIONS: R.O. Booster Pump
BYPASS: 100 PSI

DIMENSIONS:

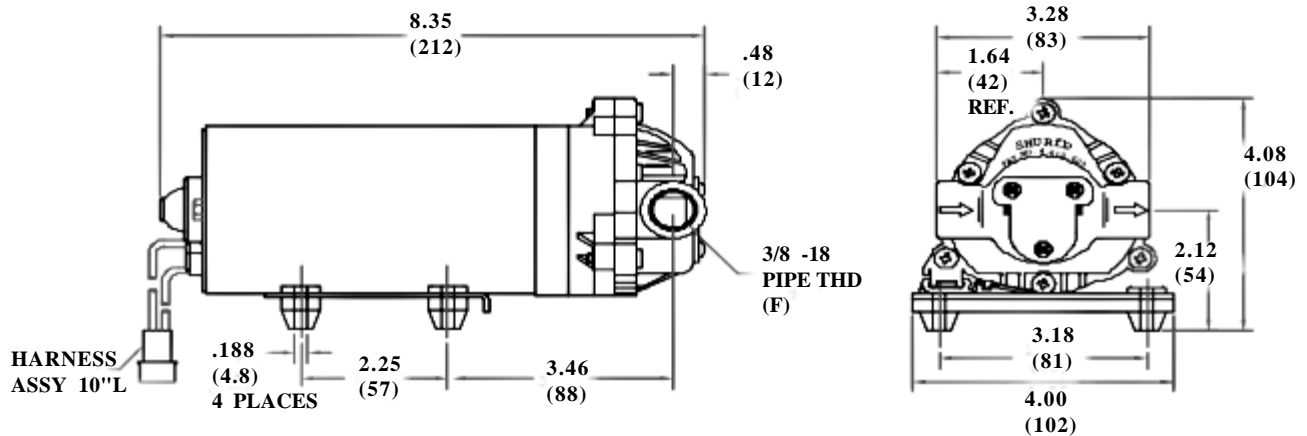

TEMPERATURE RISE

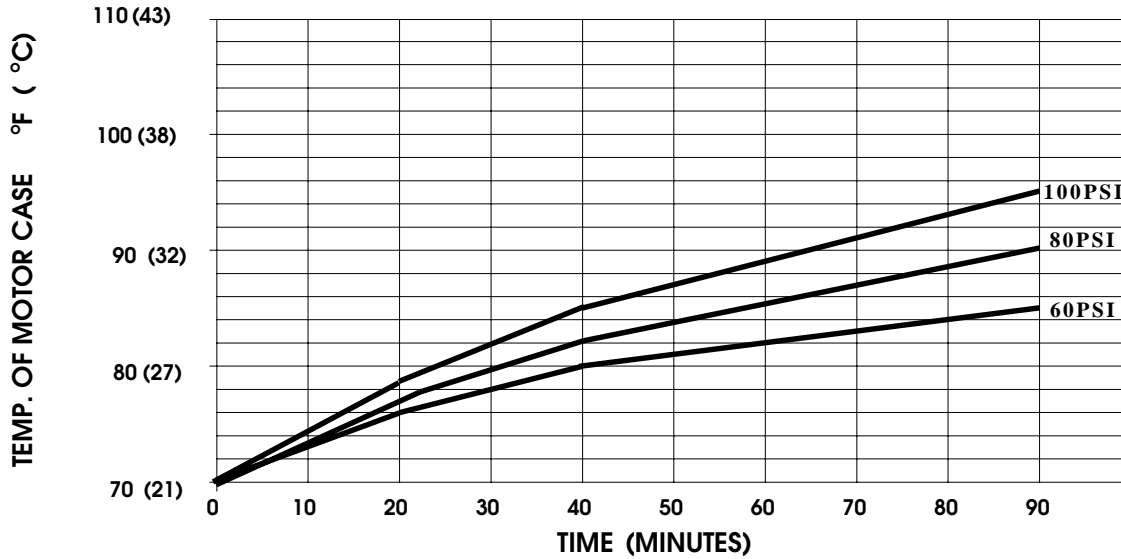

THIS GRAPH IS FOR USE AS A DESIGN GUIDE. IT IS BASED ON RUNNING CONTINUOUSLY WITH AN AMBIENT TEMPERATURE OF 75° F IN STILL AIR.

TYPICAL PERFORMANCE

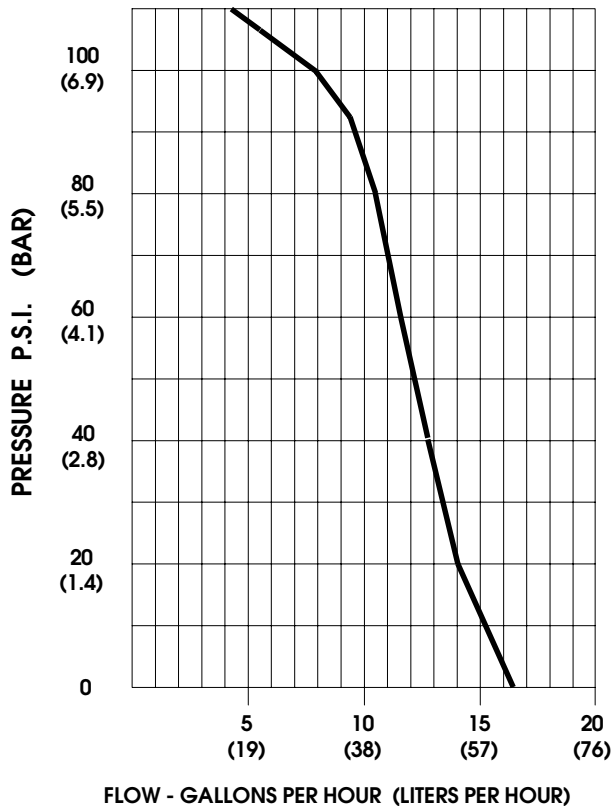

PRESSURE (PSI)	FLOW (GPH/LIT)	RPM MIN/MAX	CURRENT (AMPS)	VOLTAGE (VOLTS)
OPEN	16.3/61.7	620/640	0.24	24VDC
10	14.7/55.6	610/630	0.29	"
20	13.9/52.6	600/615	0.35	"
30	13.3/50.3	590/605	0.40	"
40	12.7/48.1	575/590	0.46	"
50	12.0/45.4	570/580	0.52	"
60	11.5/43.5	555/565	0.57	"
70	10.9/41.2	545/560	0.63	"
80	10.4/39.3	535/545	0.67	"
90	9.8/37.1	530/540	0.72	"
100	8.1/30.6	525/530	0.74	"

-SPECIFICATIONS SUBJECT TO CHANGE WITHOUT NOTICE.

-ALL DATA BASED ON TESTING WITH WATER AT AMBIENT TEMPERATURE.