

### SPECIFICATIONS:

**MODEL NUMBER:** 8005-932-260

**PUMP DESIGN:** Positive Displacement 3 Chamber Diaphragm Pump

**CAM:** 2.5 Degree

**MOTOR:** Permanent Magnet, P/N 11-150-00

**VOLTAGE:** 115 VAC Nominal

**PRESSURE SWITCH:** None

**LIQUID TEMPERATURE:** 180 Degrees Fahrenheit (82 Degrees Centigrade) Max.

**PRIME:** Self-Priming Up To 14 Ft. Vertical,  
Max. Inlet Pressure 30 PSI (2.1 Bar)

**PORTS:** 3/8"-18 NPT Female

**MATERIAL OF CONSTRUCTION:**

**PLASTICS-** Nylon

**VALVES-** EPDM

**DIAPHRAGM-** Santoprene

**FASTENERS-** Zinc Plated Steel

**NET WEIGHT:** 4.75 Lbs (2.15 Kg)

**DUTY CYCLE:** Intermittent (See Temperature Rise Chart)

**APPROVALS:** NSF Listed

**TYPICAL APPLICATIONS:** Carbonator

**BYPASS:** 120 PSI

### DIMENSIONS:

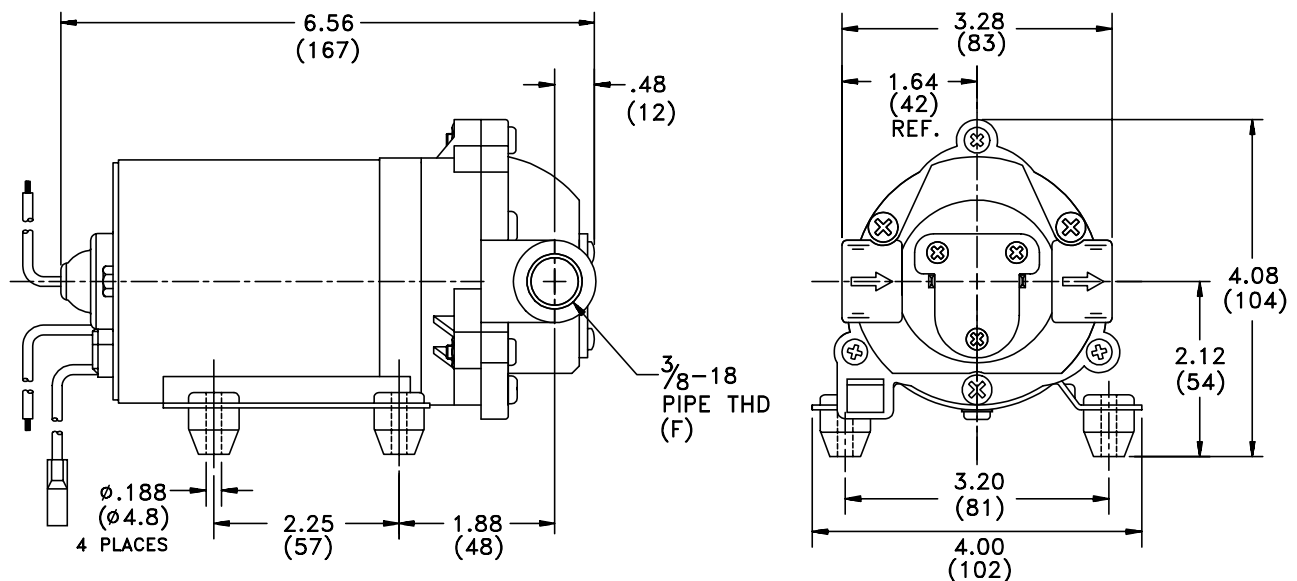

**TEMPERATURE RISE**

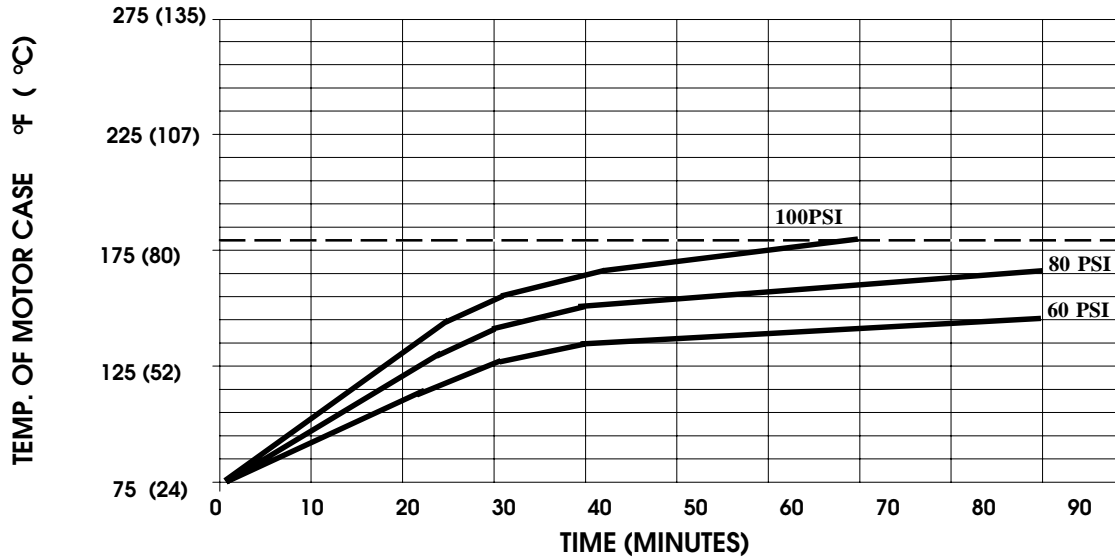

THIS GRAPH IS FOR USE AS A DESIGN GUIDE. IT IS BASED ON RUNNING CONTINUOUSLY WITH AN AMBIENT TEMPERATURE OF 70°F IN STILL AIR. THE THERMAL BREAKER WILL OPEN WHEN THE CASE TEMPERATURE REACHES 180° F.

[----- TRIP POINT OF THERMAL BREAKER]

**TYPICAL PERFORMANCE**

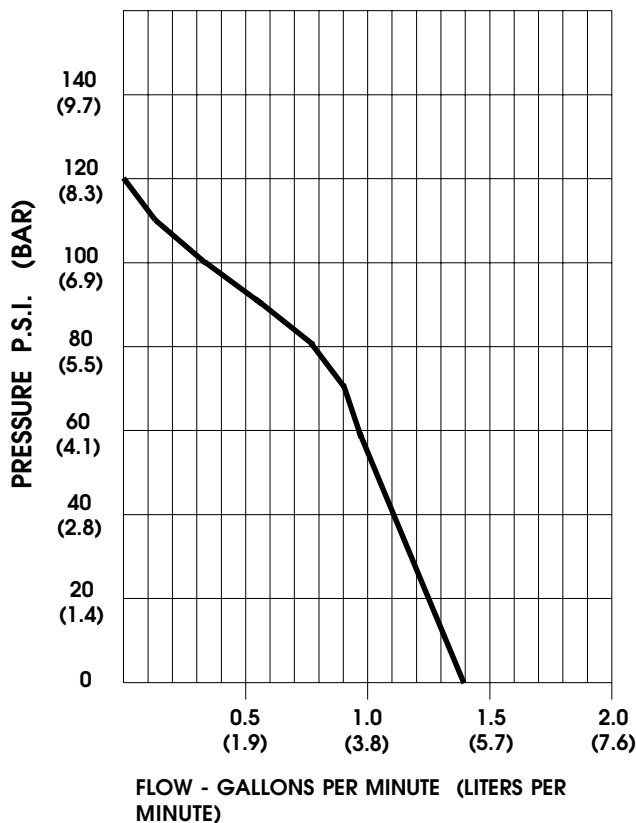

PRESSURE (PSI)	FLOW (GPM/LIT)	RPM MIN/MAX	CURRENT (AMPS)	VOLTAGE (VOLTS)
OPEN	1.39/5.3	2315/2370	0.36	115 VAC
10	1.32/5.0	2255/2280	0.40	"
20	1.17/4.4	2115/2150	0.47	"
30	1.07/4.0	2025/2035	0.53	"
40	0.98/3.7	1925/1935	0.60	"
50	0.93/3.5	1815/1845	0.66	"
60	0.87/3.3	1725/1755	0.71	"
70	0.83/3.1	1650/1675	0.76	"
80	0.76/2.9	1585/1610	0.81	"
90	0.64/2.4	1535/1565	0.85	"
100	0.36/1.4	1490/1530	0.91	"

*-SPECIFICATIONS SUBJECT TO CHANGE WITHOUT NOTICE.  
-ALL DATA BASED ON TESTING WITH WATER.*