

SPECIFICATIONS:

MODEL NUMBER: 8005-233-236

PUMP DESIGN: Positive Displacement 3 Chamber Diaphragm Pump

CHECK VALVE: (2-Way Op.) Prevents Reverse Flow & 6 Ft. Head Forward Flow

CAM: 3.0 Degree

MOTOR: Permanent Magnet, P/N 11-150-00, Thermally Protected

VOLTAGE: 115 VAC Nominal

PRESSURE SWITCH: Adjustable Shut-Off (Range 40-60 PSI)

Factory Set @ 60 PSI, Turn On 45 PSI ± 5 PSI

LIQUID TEMPERATURE: 170 Degrees Fahrenheit (77 Degrees Centigrade) Max.

PRIME: Self-Priming Up To 8.0 Ft. Vertical,
Max. Inlet Pressure 30 PSI (2.1 Bar)

PORTS: 3/8"-18 NPT Female

MATERIAL OF CONSTRUCTION:

PLASTICS- Polypropylene

VALVES- EPDM

DIAPHRAGM- Santoprene

FASTENERS- Zinc Plated Steel

NET WEIGHT: 3.8 Lbs (1.72 Kg)

DUTY CYCLE: Intermittent (See Temperature Rise Chart)

APPROVALS: UL/CSA Recognized Component, NSF Listed

TYPICAL APPLICATIONS: Soil Extraction, Water Delivery

DIMENSIONS:

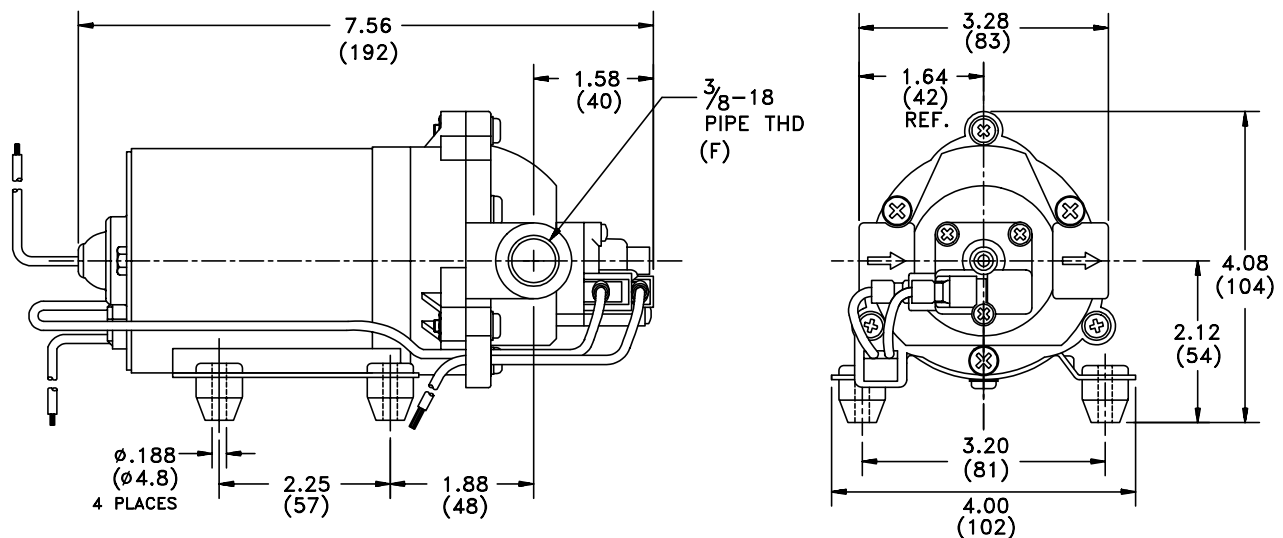

TEMPERATURE RISE

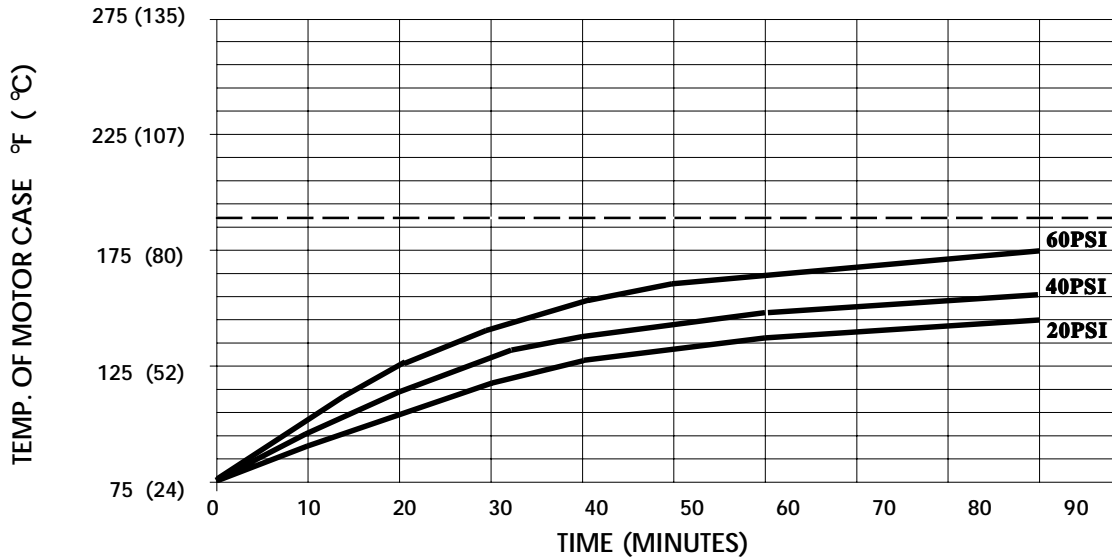

THIS GRAPH IS FOR USE AS A DESIGN GUIDE. IT IS BASED ON RUNNING CONTINUOUSLY WITH AN AMBIENT TEMPERATURE OF 75° F IN STILL AIR. THE THERMAL BREAKER WILL OPEN WHEN THE CASE TEMPERATURE REACHES 190° F.

[----- TRIP POINT OF THERMAL PROTECTOR]

TYPICAL PERFORMANCE

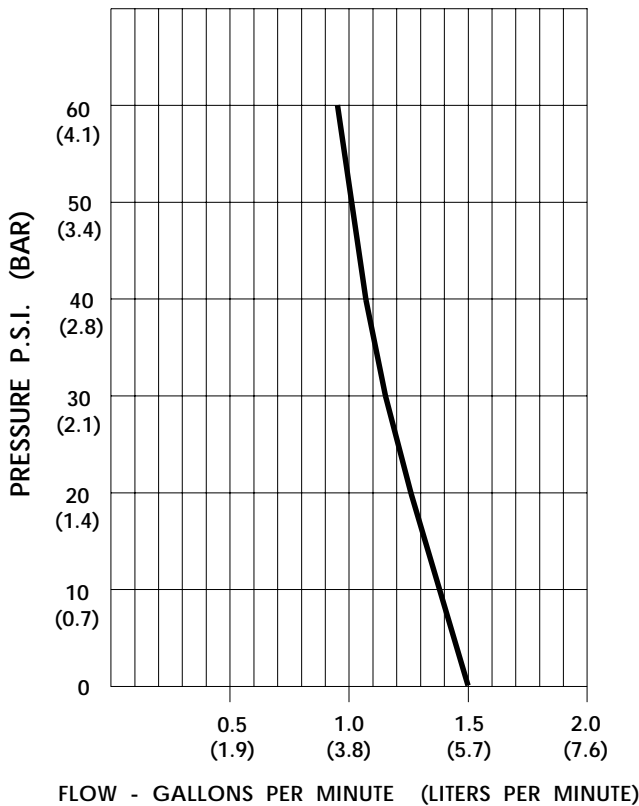

PRESSURE (PSI)	FLOW (GPM/LIT)	RPM MIN/MAX	CURRENT (AMPS)	VOLTAGE (VOLTS)
OPEN	1.51/5.7	2140/2160	0.36	115VAC
10	1.37/5.2	2025/2035	0.41	"
20	1.26/4.7	1895/1935	0.47	"
30	1.16/4.4	1765/1835	0.52	"
40	1.07/4.0	1675/1735	0.57	"
50	0.99/3.7	1595/1655	0.61	"
60	0.94/3.5	1520/1585	0.66	"

-SPECIFICATIONS SUBJECT TO CHANGE WITHOUT NOTICE.

-ALL DATA BASED ON TESTING WITH WATER.