

SPECIFICATIONS:

MODEL NUMBER: 8000-883-138

PUMP DESIGN: Positive Displacement 3 Chamber Diaphragm Pump

CHECK VALVE: (1-Way Operation) Prevents Reverse Flow

CAM: 3.0 Degree

MOTOR: Permanent Magnet, P/N 11-179-00

VOLTAGE: 36 VDC Nominal

PRESSURE SWITCH: Adjustable Shut-Off (Range 80-100 PSI)

Factory Set @100 PSI, Turn On 75 PSI \pm 5 PSI

LIQUID TEMPERATURE: 180 Degrees Fahrenheit (82 Degrees Centigrade) Max.

PRIME: Self-Priming Up To 10 Ft. Vertical,

Max. Inlet Pressure 30 PSI (2.1 Bar)

PORTS: 1/2"-14 Male Parallel Thread

MATERIAL OF CONSTRUCTION:

PLASTICS- Nylon

VALVES- Viton

DIAPHRAGM- Santoprene

FASTENERS- Zinc Plated Steel

NET WEIGHT: 4.85 Lbs (2.2 Kg)

DUTY CYCLE: Intermittent (See Temperature Rise Chart)

TYPICAL APPLICATIONS: Soil Extraction

DIMENSIONS:

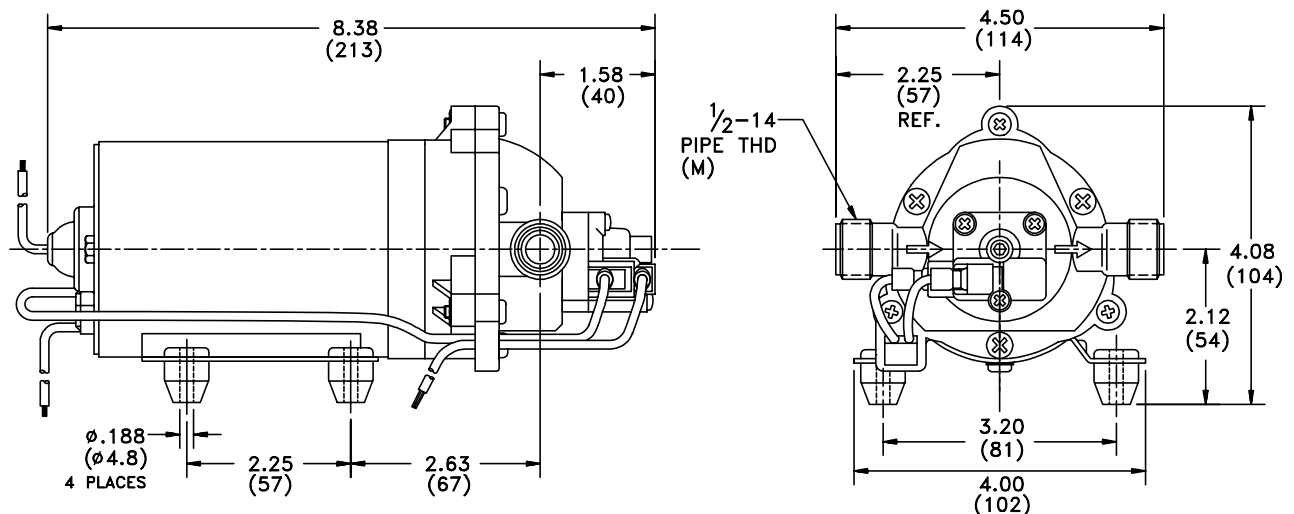

TEMPERATURE RISE

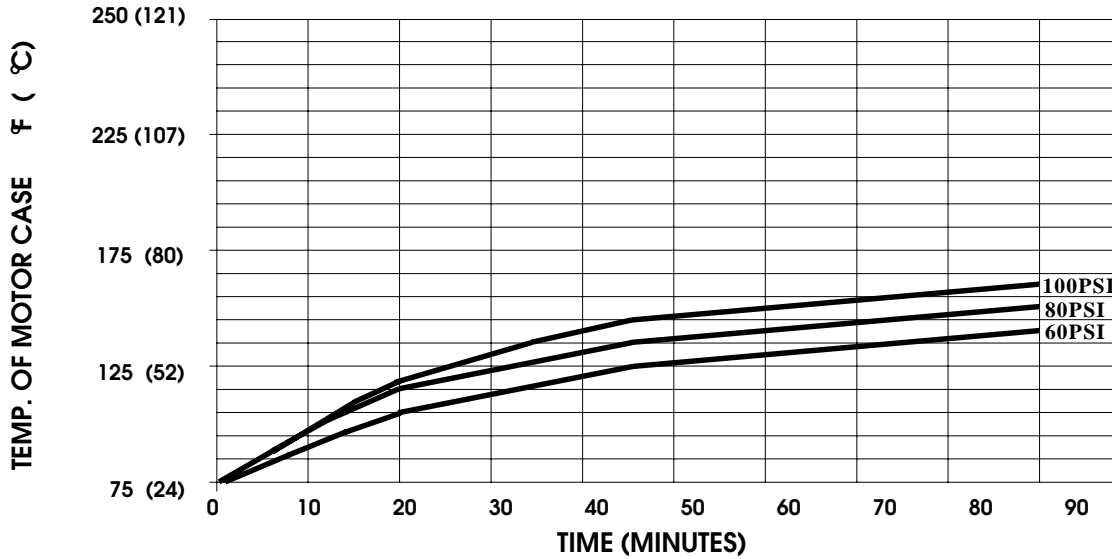

THIS GRAPH IS FOR USE AS A DESIGN GUIDE. IT IS BASED ON RUNNING CONTINUOUSLY WITH AN AMBIENT TEMPERATURE OF 75° F IN STILL AIR.

TYPICAL PERFORMANCE

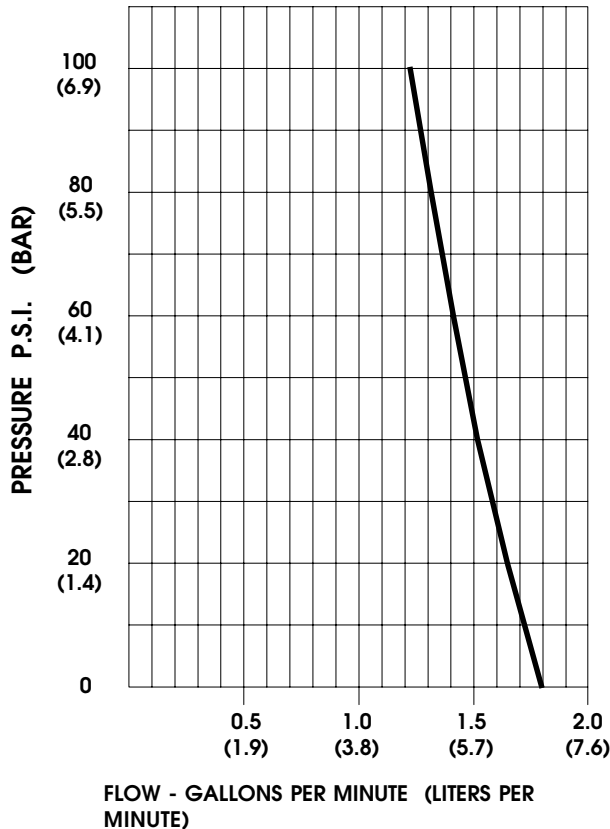

PRESSURE (PSI)	FLOW (GPM/LIT)	RPM MIN/MAX	CURRENT (AMPS)	VOLTAGE (VOLTS)
OPEN	1.80/6.8	2400/2435	1.25	36 VDC
10	1.73/6.5	2370/2415	1.50	"
20	1.65/6.2	2345/2390	1.70	"
30	1.58/6.0	2330/2365	1.95	"
40	1.52/5.8	2300/2345	2.20	"
50	1.46/5.5	2280/2330	2.40	"
60	1.41/5.3	2260/2310	2.55	"
70	1.35/5.1	2240/2290	2.75	"
80	1.31/5.0	2220/2275	2.85	"
90	1.26/4.8	2195/2250	3.10	"
100	1.22/4.6	2180/2230	3.30	"

-SPECIFICATIONS SUBJECT TO CHANGE WITHOUT NOTICE.

-ALL DATA BASED ON TESTING WITH WATER AT AMBIENT TEMPERATURE.