

SPECIFICATIONS:

MODEL NUMBER: 8000-853-138

PUMP DESIGN: Positive Displacement 3 Chamber Diaphragm Pump

CHECK VALVE: (1-Way Operation) Prevents Reverse Flow

CAM: 3.0 Degree

MOTOR: Permanent Magnet, P/N 11-127-10

VOLTAGE: 24 VDC Nominal

PRESSURE SWITCH: Adjustable Shut-Off (Range 80-100 PSI)

Factory Set @ 100 PSI, Turn On 85 PSI ± 5 PSI

LIQUID TEMPERATURE: 180 Degrees Fahrenheit (82 Degrees Centigrade) Max.

PRIME: Self-Priming Up To 9 Ft. Vertical,

Max. Inlet Pressure 30 PSI (2.1 Bar)

PORTS: 1/2"-14 Male Parallel Thread

MATERIAL OF CONSTRUCTION:

PLASTICS- Nylon

VALVES- Viton

DIAPHRAGM- Santoprene

FASTENERS- Zinc Plated Steel

NET WEIGHT: 4.7 Lbs (2.13 Kg)

DUTY CYCLE: Intermittent (See Temperature Rise Chart)

TYPICAL APPLICATIONS: Soil Extraction

DIMENSIONS:

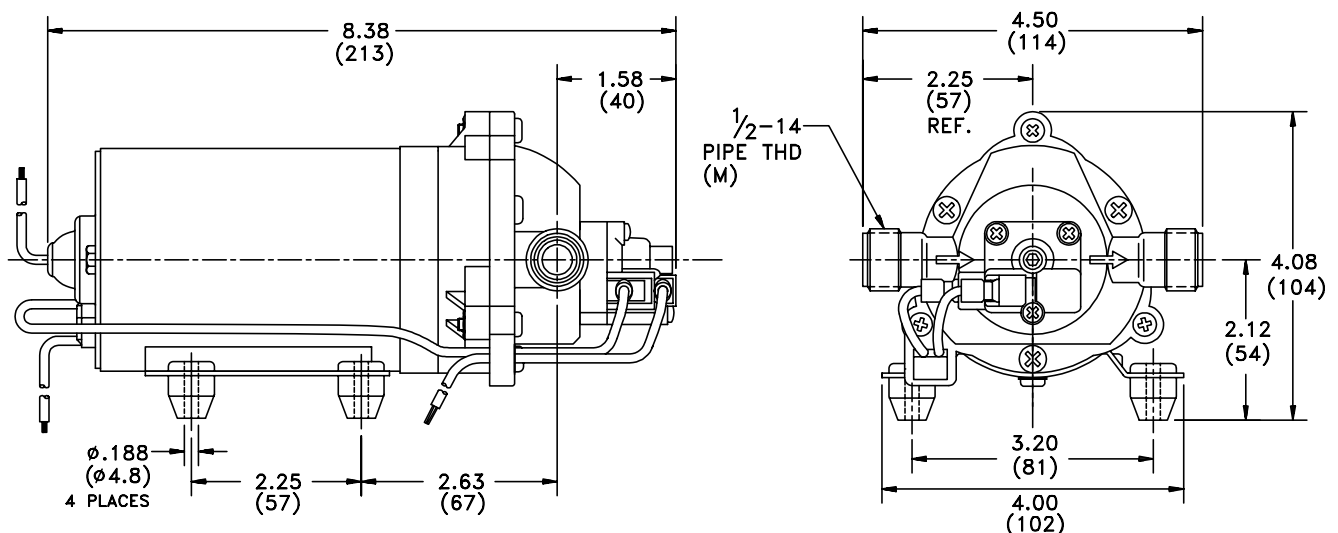

TEMPERATURE RISE

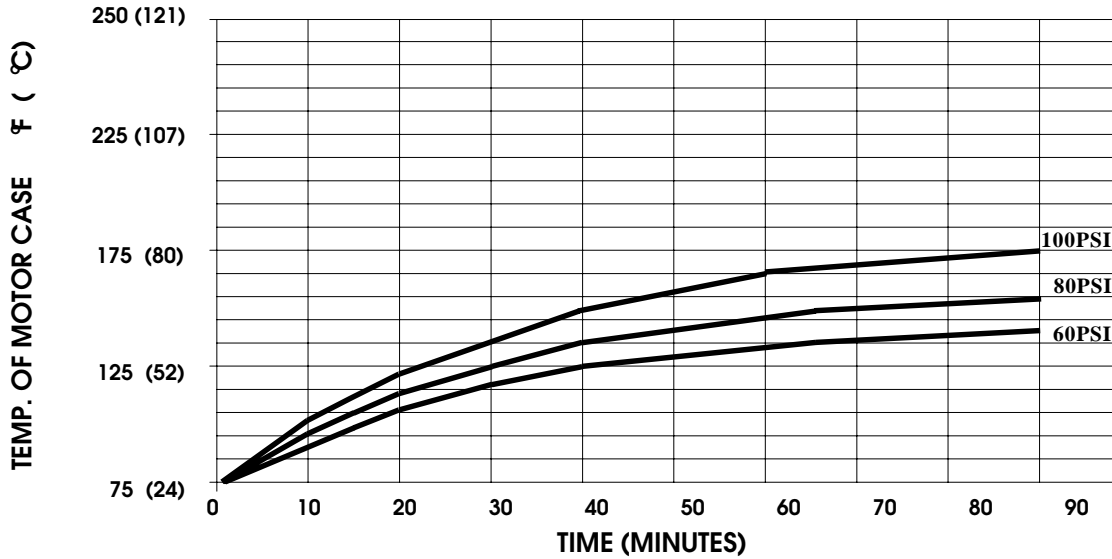

THIS GRAPH IS FOR USE AS A DESIGN GUIDE. IT IS BASED ON RUNNING CONTINUOUSLY WITH AN AMBIENT TEMPERATURE OF 70° F IN STILL AIR.

TYPICAL PERFORMANCE

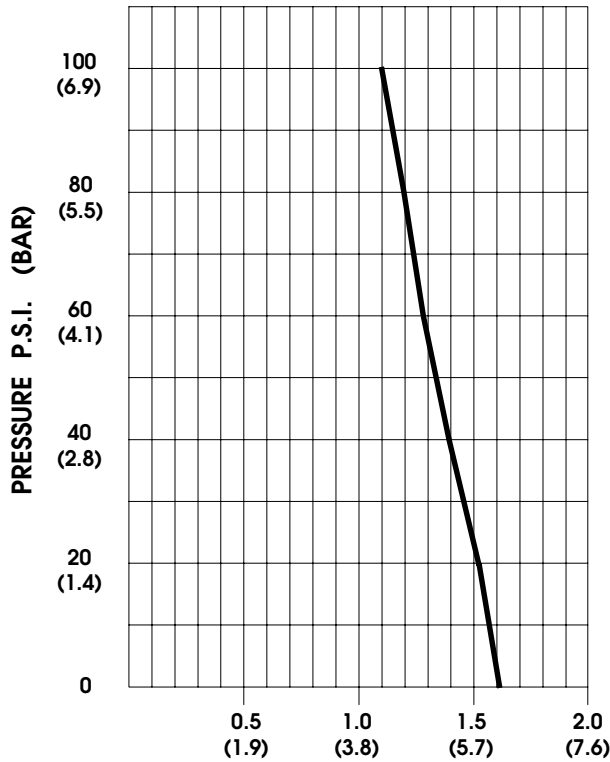

PRESSURE (PSI)	FLOW (GPM/LIT)	RPM MIN/MAX	CURRENT (AMPS)	VOLTAGE (VOLTS)
OPEN	1.58/6.0	2305/2320	1.8	24VDC
10	1.57/5.9	2280/2295	2.1	"
20	1.53/5.8	2240/2265	2.4	"
30	1.46/5.5	2200/2240	2.7	"
40	1.39/5.3	2145/2218	3.0	"
50	1.33/5.0	2115/2190	3.3	"
60	1.28/4.8	2090/2160	3.5	"
70	1.24/4.7	2065/2132	3.8	"
80	1.20/4.5	2030/2110	4.1	"
90	1.15/4.4	2000/2080	4.3	"
100	1.11/4.2	1970/2050	4.5	"

-SPECIFICATIONS SUBJECT TO CHANGE WITHOUT NOTICE.

-ALL DATA BASED ON TESTING WITH WATER AT AMBIENT TEMPERATURE.