

SPECIFICATIONS:

MODEL NUMBER: 8000-053-210
PUMP DESIGN: Positive Displacement 3 Chamber Diaphragm Pump
CAM: 3.0 Degree
MOTOR: Permanent Magnet, P/N 11-181-00
VOLTAGE: 24 VDC Nominal
PRESSURE SWITCH: None
LIQUID TEMPERATURE: 180 Degrees Fahrenheit (82 Degrees Centigrade) Max.
PORTS: 3/8"-18 NPT Female
PRIME: Self-Priming Up To 10 Ft. Vertical,
 Max. Inlet Pressure 30 PSI (2.1 Bar)
MATERIAL OF CONSTRUCTION:
PLASTICS- Nylon
VALVES- Viton
DIAPHRAGM- Geolast
FASTENERS- Steel (Zinc Plated)
NET WEIGHT: 5.80 Lbs (2.6 Kg)
DUTY CYCLE: Continuous (See Temperature Rise Chart)
TYPICAL APPLICATIONS: Road Roller Equipment
BYPASS: 35 PSI

DIMENSIONS:

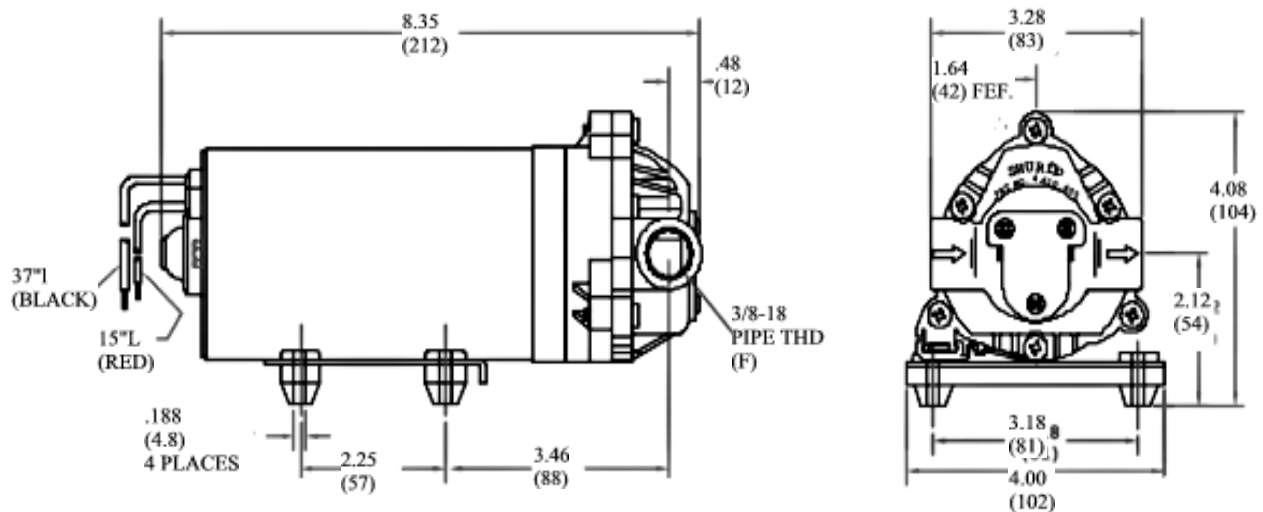

TEMPERATURE RISE

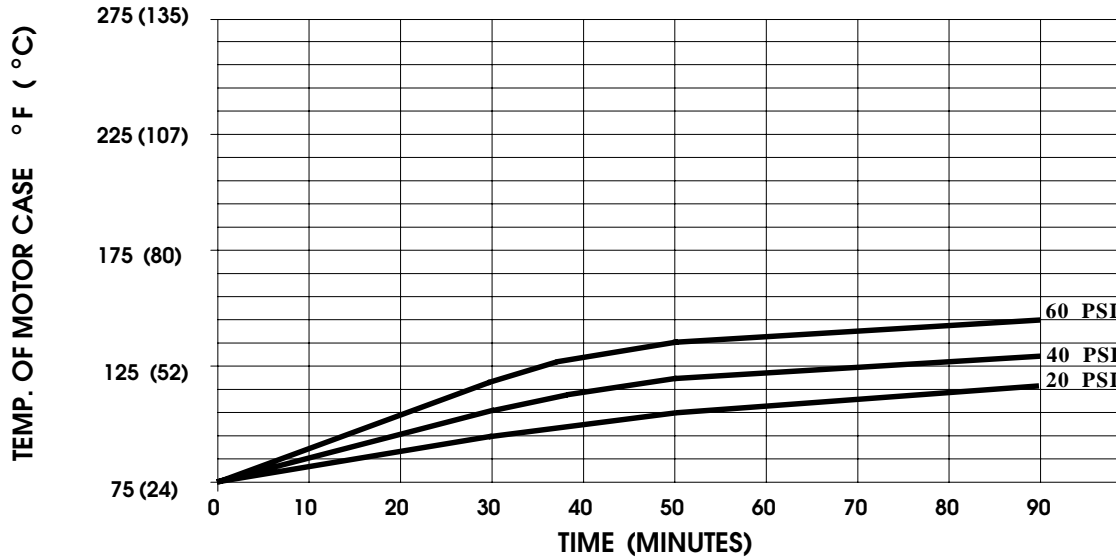

THIS GRAPH IS FOR USE AS A DESIGN GUIDE. IT IS BASED ON RUNNING CONTINUOUSLY WITH AN AMBIENT TEMPERATURE OF 70 ° F IN STILL AIR.

TYPICAL PERFORMANCE

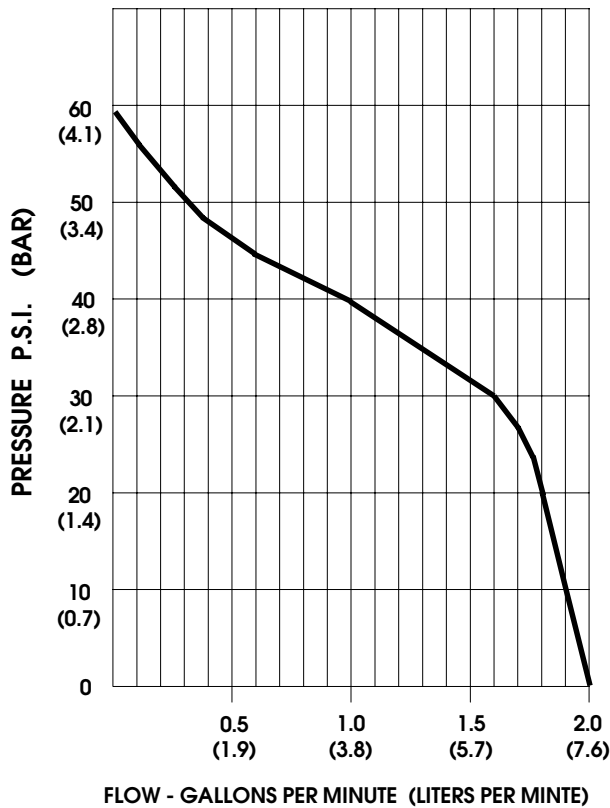

PRESSURE (PSI)	FLOW (GPM/LIT)	RPM MIN/MAX	CURRENT (AMPS)	VOLTAGE (VOLTS)
OPEN	2.0/7.6	2475/2550	2.2	24 VDC
10	1.9/7.2	2470/2540	2.4	"
20	1.8/6.8	2445/2515	2.7	"
30	1.6/6.0	2425/2500	3.0	"
40	1.0/3.8	2420/2485	3.2	"
50	0.3/1.1	2395/2470	3.5	"
60	.01/0.3	2390/2465	3.6	"

-SPECIFICATIONS SUBJECT TO CHANGE WITHOUT NOTICE.

-ALL DATA BASED ON TESTING WITH WATER AT AMBIENT TEMPERATURE.