

# ~~Extreme~~ Series



## MARINE PRODUCT DATA SHEET

OEM: 5902-3202  
 AFTERMARKET: 5902-3212

The most advance system available, this fully-automatic, quit unit pumps tasteless, odorless water smoothly and consistently. Corrosion resistance and NSF certified tank.

### TYPICAL APPLICATIONS

Multi-fixture marine fresh water installations. Other uses may included 24V DC pressurized water systems in cabins This pump may be used for general water transfer. For other applications, contact SHURflo.

### PUMP

Type: 5 Chamber Diaphragm  
 Ports: Quick Connect Fittings.  
 Liquid: 130 °F [54 °C] Max  
 Prime: 6 feet [1.82 M]  
 Inlet PSI: 30 PSI [2.1 Bar] Max  
 Run Dry: Yes

### ELECTRICAL

Motor: 24VDC Permanent Magnet, Intermittent Duty  
 Protection: Thermal Overload, Automatic Restart  
 Leads: 14 AWG, 16" [40 cm] Red +, 13" [33 cm] Black -  
 Fuse: 10 Amp Recommended  
 Control: Adjustable Switch. Shut-Off 45 PSI [3.1 Bar] ± 5 PSI [0.4 Bar]  
 Restart 25 PSI [1.8 Bar] ± 5 PSI [0.4 Bar]

### MATERIALS

Housing: Nylon  
 Valves: EPDM  
 Diaphragm: Santoprene  
 Hardware: Stainless Steel

### APPROVALS

Ignition Protected, CE, ISO 8846

### WARRANTY

3 Year Limited Warranty  
 See SB-1041 & SB-1050 For Full Warranty Details

### SHIPPING

Net Weight (Boxed): 21 Lb [9.5 Kg] each  
 Carton Weight: each Lb [Kg]  
 Carton Size: 18"L x16 "W x17 "H  
 [45.7 cm x40.6 cm x43.1 cm]

### RELATED DOCUMENTS

Catalog: MS-030-140  
 Installation Manual: 911-670  
 Maintenance: 911-670  
 Applications Spec Guide: MS-020-005  
 Warranty: SB-1050

**Replacement Kits**

Number	Description	Part Number
1	Housing / Switch	94-069-00
2	Valve Assembly	94-030-01
3	Drive Assembly	94-030-02
4	Motor	77-009-17
No shown	SS Tank	3400-002



PERFORMANCE @ 24V DC

PRESSURE		FLOW		CURRENT
BAR	PSI	GPM	LPM	AMPS
0.0	0	5.5	20.8	3.05
0.7	10	5.0	18.9	3.85
1.4	20	4.4	16.6	4.75
2.1	30	3.8	14.3	5.60
2.8	40	3.2	12.1	6.60

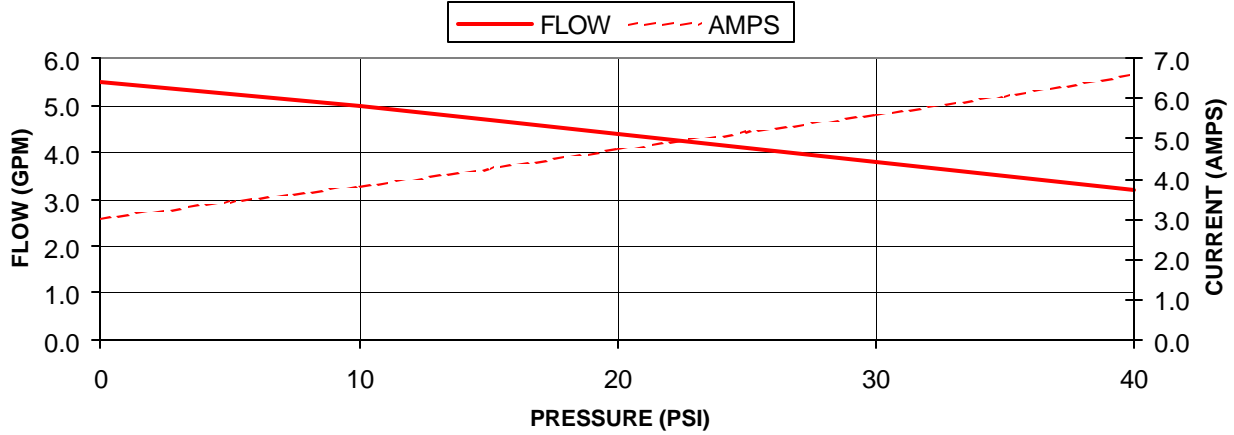

DIMENSIONS [mm]

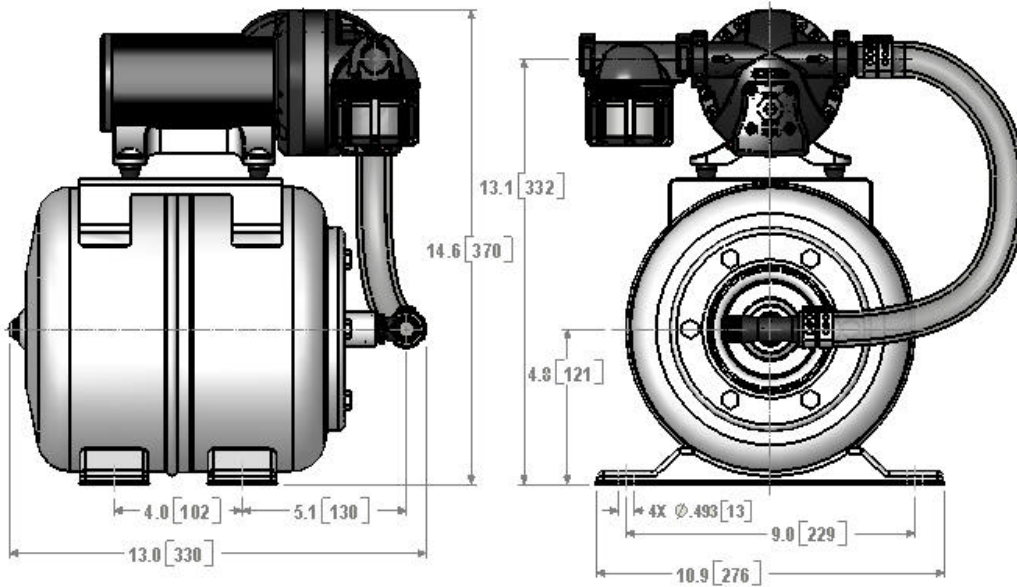

\*ISO Registered Facility SHURflo reserves the right to update specifications, prices, or make substitutions.

SHURflo \*  
5900A Katella Ave.  
Cypress, Ca. 90630  
(800) 854-3218 (562) 795-5200  
FAX (562) 795-7554  
Shipping/UPS: 5900C Katella Ave.  
Cypress, Ca. 90630

SHURflo East  
52748 Park Six Court  
Elkhart, IN 46514-5427  
(800) 762-809 (574) 262-0478  
FAX (574) 264-2169  
Http://www.shurflo.com  
©2001

SHURflo Ltd. \*  
Unit 5 Sterling Park  
Gatwick Road, Crawley  
West Sussex, RH10 2QT  
United Kingdom  
+44 1293 424000  
FAX +44 1293 421880

