

~~Extreme~~ Series



MARINE PRODUCT DATA SHEET

OEM: 5901-2202
AFTERMARKET: 5901-2212

The Extreme Pro Blaster delivers over 5 GPM and pressure up to 45 psi, giving you the ultimate in washdown capabilities. This high volume pump will clean your deck quickly and easily. The corrosion resistant coated seamless motor shell with sealed switch provides excellent protection against the harsh marine environment. The Extreme Pro Blaster is designed for the toughest washdown applications.

TYPICAL APPLICATIONS

Marine washdown installations. Other uses may included 12V DC pressurized water systems in cabins This pump may be used for general water transfer. For other applications, contact SHURflo.

PUMP

Type: 5 Chamber Diaphragm
Ports: Quick Connect Fittings.
Liquid: 130 °F [54 °C] Max
Prime: 6 feet [1.82 M]
Inlet PSI: 30 PSI [2.1 Bar] Max
Run Dry: Yes

ELECTRICAL

Motor: 12VDC Permanent Magnet, Intermittent Duty
Protection: Thermal Overload, Automatic Restart
Leads: 14 AWG, 16" [40 cm] Red +, 13" [33 cm] Black -
Fuse: 20 Amp Recommended
Control: Adjustable Switch. Shut-Off 45 PSI [3.1 Bar] ± 5 PSI [0.4 Bar]
Restart 25 PSI [1.8 Bar] ± 5 PSI [0.4 Bar]

MATERIALS

Housing: Nylon
Valves: EPDM
Diaphragm: Santoprene
Hardware: Stainless Steel

APPROVALS

Ignition Protected, CE, ISO 8846

WARRANTY

3 Year Limited Warranty
See SB-1041 & SB-1050 For Full Warranty Details

SHIPPING

Net Weight (Boxed): 8.5 Lb [3.9Kg] each
Carton Weight: 6 each, 51 Lb [24 Kg]
Carton Size: 25"L x 19"W x 8"H
[63cm x 49cm x21cm]

RELATED DOCUMENTS

Catalog: MS-030-140
Installation Manual: 911-622
Maintenance: 911-622
Applications Spec Guide: MS-020-005
Warranty: SB-1050

Replacement Kits

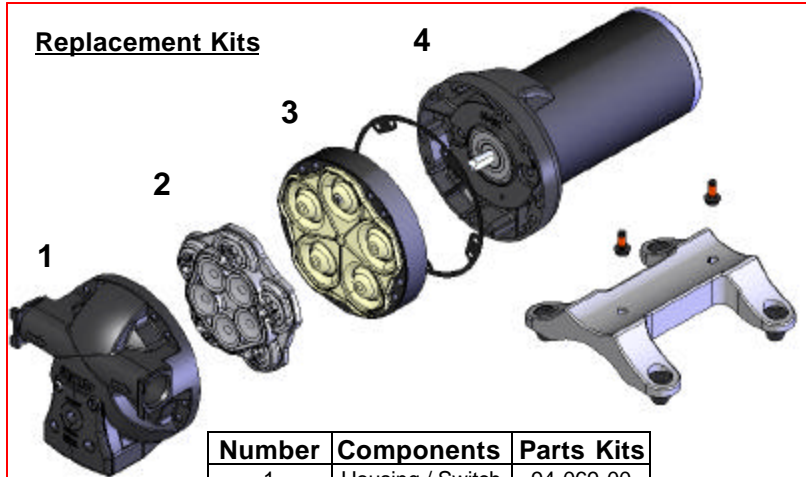

Number	Components	Parts Kits
1	Housing / Switch	94-069-00
2	Valve Assembly	94-030-01
3	Drive Assembly	94-030-02
4	Motor	77-007-17



PERFORMANCE @ 12V DC

PRESSURE		FLOW		CURRENT
BAR	PSI	GPM	LPM	AMPS
0.0	0	5.5	20.8	5.2
0.7	10	4.0	15.1	7.5
1.4	20	3.5	13.2	9.2
2.1	30	2.8	10.5	11
2.8	40	2.2	8.3	12.4

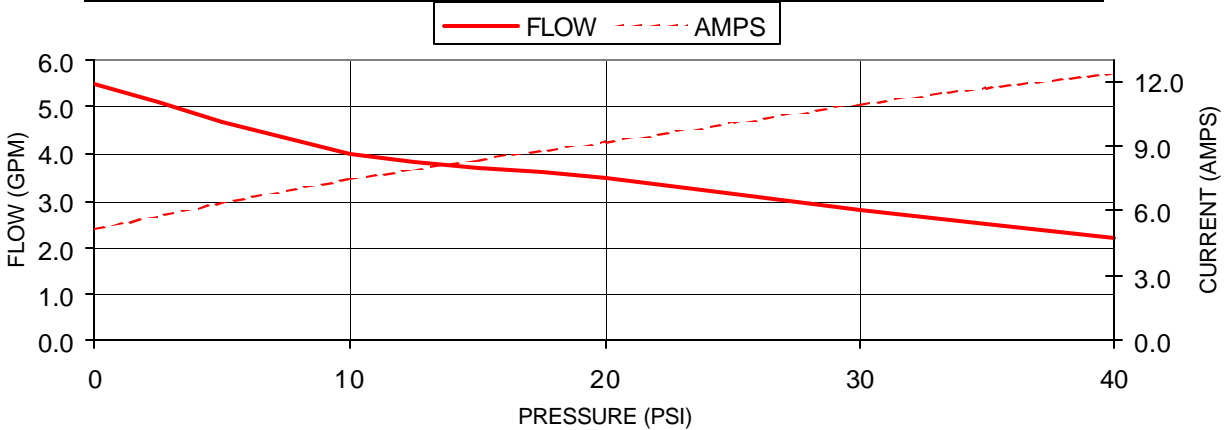

DIMENSIONS [mm]

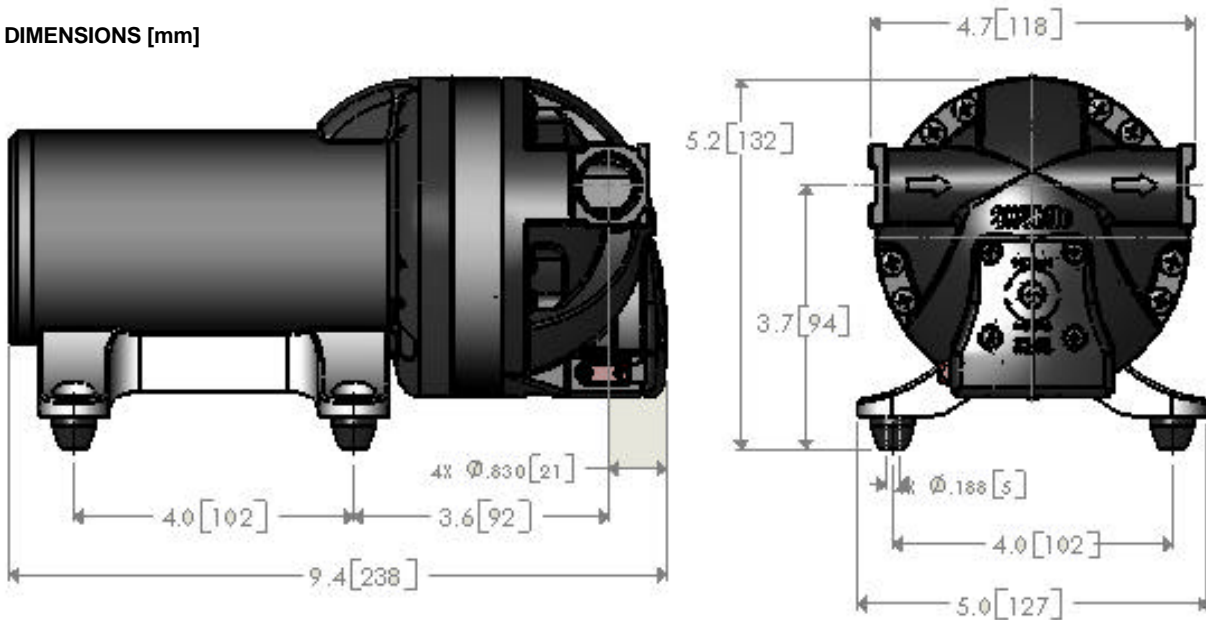

*ISO Registered Facility SHURflo reserves the right to update specifications, prices, or make substitutions.

SHURflo *
 5900A Katella Ave.
 Cypress, Ca. 90630
 (800) 854-3218 (562) 795-5200
 FAX (562) 795-7554
 Shipping/UPS: 5900C Katella Ave.
 Cypress, Ca. 90630

SHURflo East
 52748 Park Six Court
 Elkhart, IN 46514-5427
 (800) 762-809 (574) 262-0478
 FAX (574) 264-2169
 Http://www.shurflo.com
 ©2001

SHURflo Ltd. *
 Unit 5 Sterling Park
 Gatwick Road, Crawley
 West Sussex, RH10 2QT
 United Kingdom
 +44 1293 424000
 FAX +44 1293 421880

