

# PRO Blaster™



## MARINE PRODUCT DATA SHEET

OEM: 4901-4292  
AFTERMARKET: 4901-4282

Perfect for tough washdown applications, such as fish box, scaling, and anchor chain cleaning, these rugged self-priming pump deliver high lift, can run dry without damage, and won't overheat with extended use. Pump is ignition protected and switch is sealed against water damage.

### TYPICAL APPLICATIONS

Marine fresh or salt water wash down installations. Other uses may include 12 VDC pressurized water systems. This pump may be used for general water transfer. For other applications, contact SHURflo.

### PUMP

Type: 4 Chamber Diaphragm  
Ports: 1/2"-14 NPSM-Male.  
Liquid: 130 °F [54 °C] Max  
Prime: 6 feet [1.82 M]  
Inlet PSI: 30 PSI [2.1 Bar] Max  
Run Dry: Yes

### ELECTRICAL

Motor: 12VDC Permanent Magnet, Intermittent Duty  
Protection: Thermal Overload, Automatic Restart  
Leads: 14 AWG, 16" [40 cm] Red +, 13" [33 cm] Black -  
Fuse: 15 Amp Recommended  
Control: Adjustable Switch. Shut-Off 45 PSI [3.1 Bar] ± 5 PSI [0.4 Bar]  
Restart 25 PSI [1.8 Bar] ± 5 PSI [0.4 Bar]

### MATERIALS

Housing: Nylon  
Valves: EPDM  
Diaphragm: Santoprene  
Hardware: Stainless Steel

### APPROVALS

Ignition Protected, CE, ISO 8846

### WARRANTY

2 Year Limited Warranty  
See SB-1041 & SB-1050 For Full Warranty Details

### SHIPPING

Net Weight (Boxed): Lb [Kg] each  
Carton Weight: 6 each, 42 Lb [ 19 Kg]  
Carton Size: 24"L x 18"W x 6"H  
[61 cm x 46 cm x 15 cm]

### RELATED DOCUMENTS

Catalog: MS-030-140  
Installation Manual: 911-741  
Maintenance: 911-741  
Applications Spec Guide: MS-020-005  
Warranty: SB-1050

### Replacement Kits

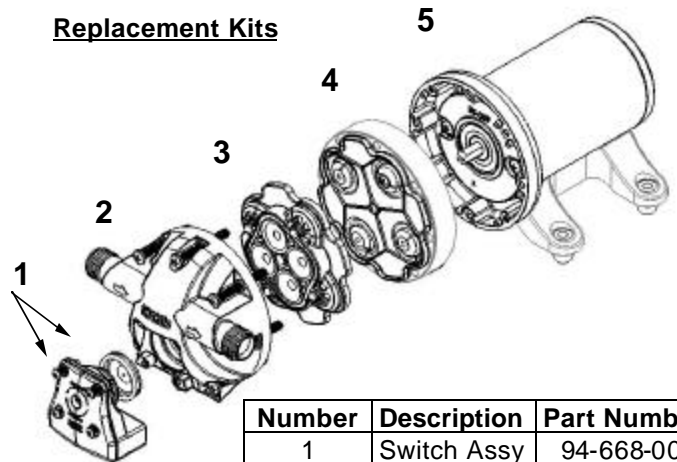

Number	Description	Part Number
1	Switch Assy	94-668-00
2	Upper Hsg	94-670-01
3	Valve Assy	94-669-00
4	Drive Assy	94-670-00
5	Motor	77-013-17



**TYPICAL PERFORMANCE @ 12V DC**

PRESSURE		FLOW		CURRENT
BAR	PSI	GPM	LPM	AMPS
0.0	0	4.0	15.1	4.1
0.7	10	3.3	12.5	6.3
1.4	20	2.9	10.1	7.6
2.1	30	2.7	10.2	8.8
2.8	40	2.4	9.0	10.0

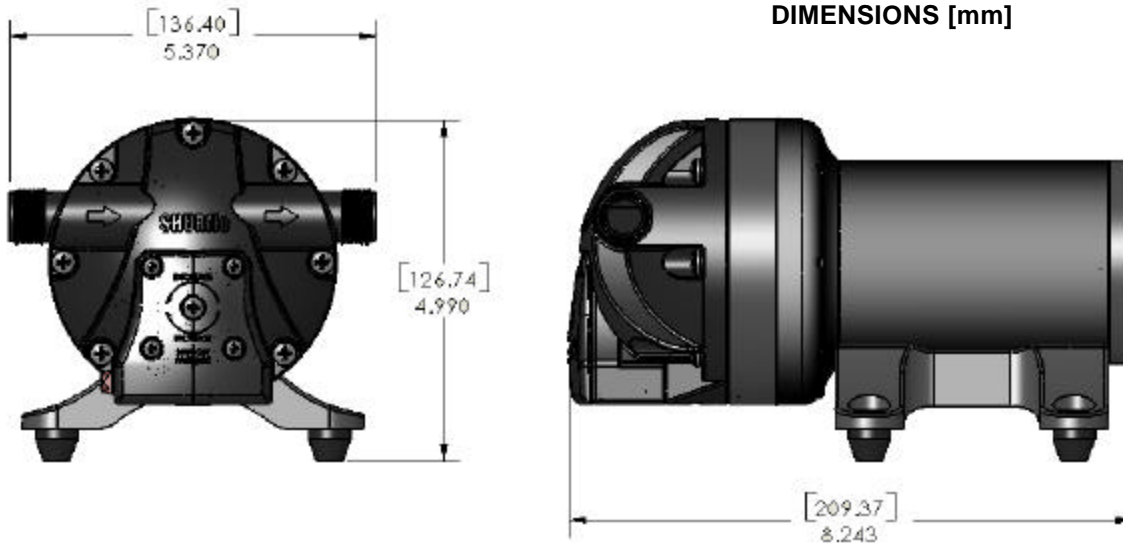
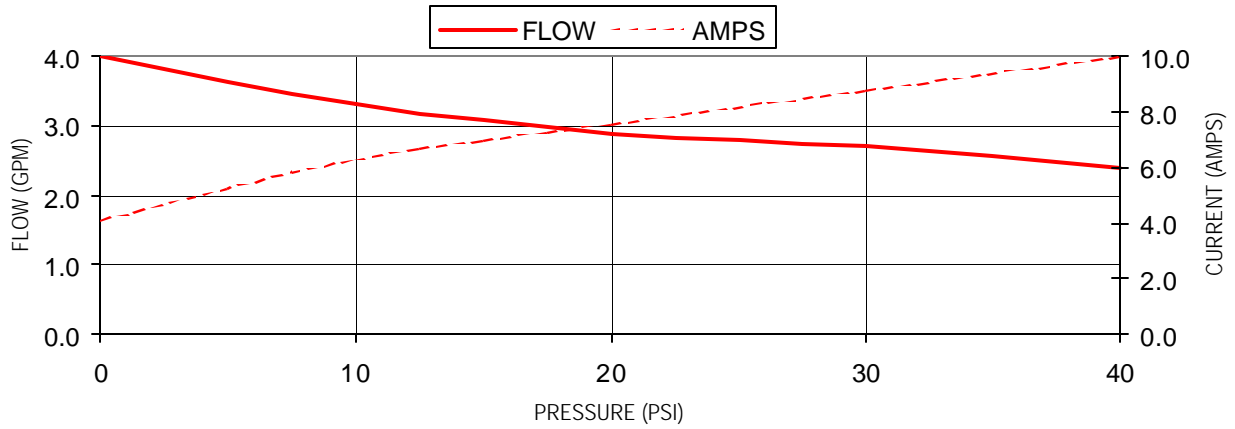

\*ISO Registered Facility *SHURflo reserves the right to update specifications, prices, or make substitutions.*

**SHURflo \***  
 5900A Katella Ave.  
 Cypress, Ca. 90630  
 (800) 854-3218 (562) 795-5200  
 FAX (562) 795-7554  
 Shipping/UPS: 5900C Katella Ave.  
 Cypress, Ca. 90630

**SHURflo East**  
 52748 Park Six Court  
 Elkhart, IN 46514-5427  
 (800) 762-809 (574) 262-0478  
 FAX (574) 264-2169  
 Http://www.shurflo.com  
 ©2001

**SHURflo Ltd. \***  
 Unit 5 Sterling Park  
 Gatwick Road, Crawley  
 West Sussex, RH10 2QT  
 United Kingdom  
 +44 1293 424000  
 FAX +44 1293 421880

