

TYPICAL APPLICATIONS

Fresh water pump debris strainer.
 Vacuum side application only.
 For other applications, contact SHURflo.

MATERIALS

Top Housing	Polypropylene
Bowl	Nylon
Gasket	EPDM
Screen	50 Mesh T304 Stainless Steel

SPECIFICATIONS

Inlet Port	1/2" NPSM [Male] or 1/2" Barb or 1/2" Swivel Nut
Outlet Port	1/2" NPSM [Male]
Max Temp.	120°F [48°C]
Max Press.	Vacuum Side Only

APPROVALS

IAPMO [Meets NSF 61]

WARRANTY

1 Year Limited Warranty
 See SB-1041 & SB-1050 For Full Warranty Details

RELATED DOCUMENTS

Catalog	MS-030-083
	MS-030-140
Installation Manual	911-689
Maintenance	911-689
Applications Spec Guide	MS-020-005
Warranty	SB-1041/SB-1050

Strainer



Typical Exploded View

---No Parts Kits Available---

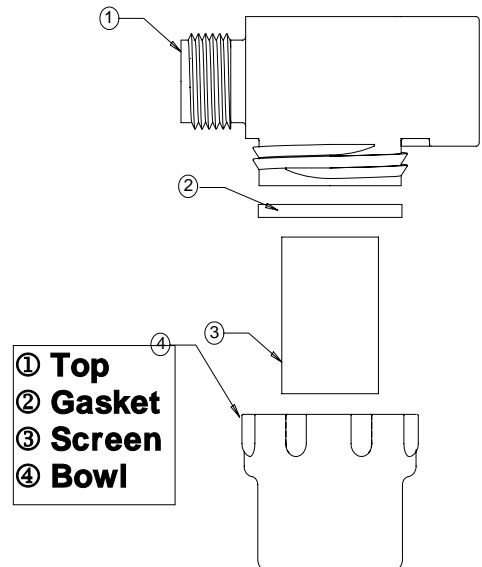

* ISO Registered Facility

SHURflo reserves the right to update specifications, prices, or make substitutions.