

Specialty Pumps



MARINE PRODUCT DATA SHEET

OEM: 2095-273-200
AFTERMARKET: 2095-273-200

Specifically designed for refrigeration cold plate circulation, this pump allows you to adjust water flow according to your system.

TYPICAL APPLICATIONS

Refrigeration cold plate circulation. This pump may be used for general water transfer. For other applications contact SHURflo.

PUMP

Type: 3 Chamber Diaphragm
Ports: 1/2"-14 NPSM-Male
Liquid: 130 °F [54 °C] Max
Prime: 6 feet [1.82 M]
Inlet PSI: 30 PSI [2.1 Bar] Max
Run Dry: Yes

ELECTRICAL

Motor: 12VDC Permanent Magnet, Continuous Duty
Protection: Thermal Overload, Automatic Restart
Leads: 16 AWG, 16" [40 cm] Red +, 13" [33 cm] Black -
Fuse: 5 Amp Recommended
Control: No Control

MATERIALS

Housing: Polypropylene
Valves: EDPM
Diaphragm: Santoprene
Hardware: Stainless Steel

APPROVALS

Ignition Protected, CE, ISO 8846

WARRANTY

1 Year Limited Warranty
See SB-1050 For Full Warranty Details

SHIPPING

Net Weight (Boxed): 5.6 Lb [2.5 Kg] each
Carton Weight: 6 each, 34 Lb [15 Kg]
Carton Size: 24"L x 18"W x 6"H [61 cm x 46cm x 15 cm]

RELATED DOCUMENTS

Catalog: MS-030-140
Installation Manual: 911-396
Maintenance: 911-396
Applications Spec Guide: MS-020-005
Warranty: SB-1050

Parts Kits

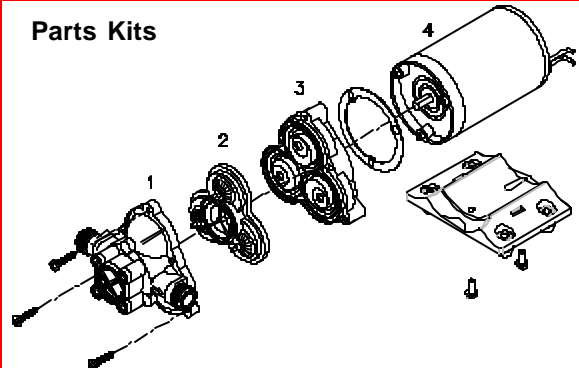

Number	Components	Parts Kits
1	Housing/Cover	--
2	Valve Assembly	94-232-06
3	Drive Assembly	94-238-04
4	Motor	11-187-12
5	Pump Head	--
Not Shown	Check Valve	94-237-00



PERFORMANCE @ 12V DC

PRESSURE		FLOW		CURRENT
BAR	PSI	GPM	LPM	AMPS
0.0	0	1.75	6.6	1.28
1.4	20	1.15	4.4	2.65
2.8	40	0.65	2.5	2.95
4.1	60	0.25	0.9	2.80
5.5	80	0.00	0.0	3.45

MOTOR SHELL T-RISE @ 40 PSI, 12V

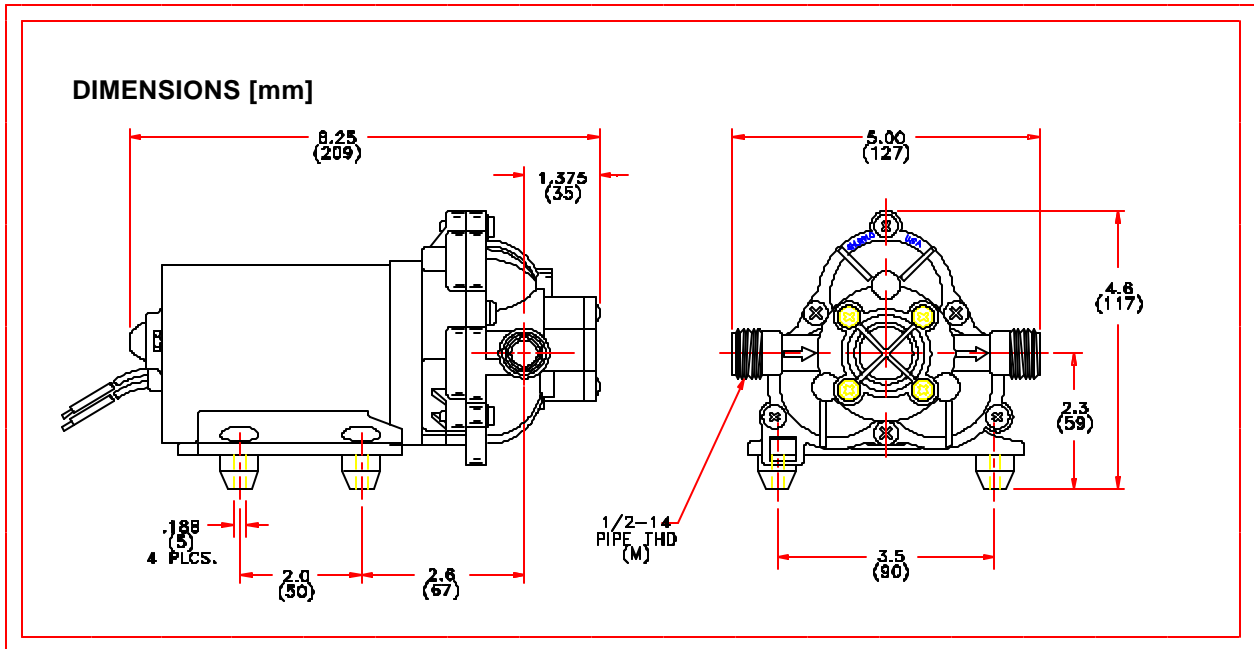
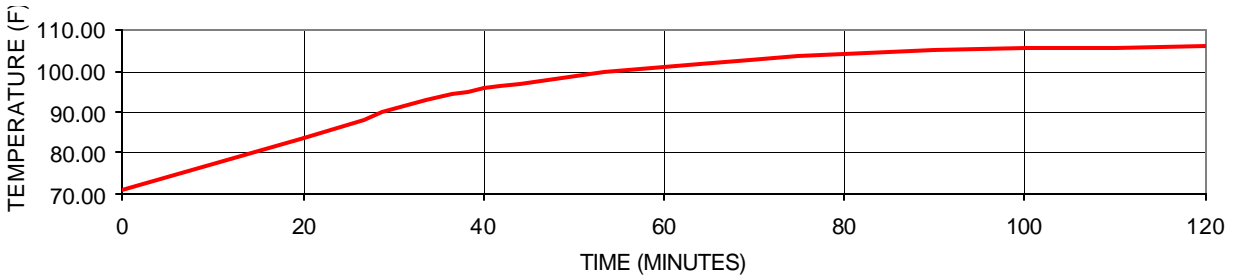

*ISO Registered Facility SHURflo reserves the right to update specifications, prices, or make substitutions.

SHURflo *
 5900A Katella Ave.
 Cypress, Ca. 90630
 (800) 854-3218 (562) 795-5200
 FAX (562) 795-7554
 Shipping/UPS: 5900C Katella Ave.
 Cypress, Ca. 90630

SHURflo East
 52748 Park Six Court
 Elkhart, IN 46514-5427
 (800) 762-809 (574) 262-0478
 FAX (574) 264-2169
 Http://www.shurflo.com
 © 2001

SHURflo Ltd. *
 Unit 5 Sterling Park
 Gatwick Road, Crawley
 West Sussex, RH10 2QT
 United Kingdom
 +44 1293 424000
 FAX +44 1293 421880

