

MARINE PRODUCT DATA SHEET

OEM 2088-723-244
 AFTERMARKET 2088-423-344



Aqua King Standard



TYPICAL APPLICATIONS

Multi-fixture marine potable water installations. Other uses may include 12 VDC pressurized water systems in cabins. This pump may be used for general water transfer. For other applications, contact SHURflo.

PUMP

Type: 3 Chamber Diaphragm
 Ports: 1/2"-14 NPSM-Male
 Liquid: 130 °F [54 °C] Max
 Prime: 6 feet [1.82 M]
 Inlet PSI: 30 PSI [2.1 Bar] Max
 Run Dry: Yes

ELECTRICAL

Motor: 12VDC Permanent Magnet, Intermittent Duty
 Protection: Thermal Overload, Automatic Restart
 Leads: 16 AWG, 16" [40 cm] Red +, 38" [33 cm] Black -
 Fuse: 10 Amp Recommended
 Control: Adjustable Switch with Check Valve Shut-Off 45 PSI
 [3.1 Bar] ± 5 PSI [0.4 Bar]
 Restart 25 PSI [1.8 Bar] ± 5 PSI [0.4 Bar]

MATERIALS

Housing: Polypropylene
 Valves: EPDM
 Diaphragm: Santoprene
 Hardware: Stainless Steel

APPROVALS

UL Marine, Ignition Protected, ISO 8846, c-UL

WARRANTY

1 Year Limited Warranty
 See SB-1050 For Full Warranty Details

SHIPPING

Net Weight (Boxed): 5 Lb [2.3Kg] each
 Carton Weight: 12 each, 52 Lb [24 Kg]
 Carton Size: 24"L x 18"W x 11"H
 [61cm x 46cm x 28cm]

RELATED DOCUMENTS

Catalog: MS-030-084
 Installation Manual: 911-448
 Maintenance: 911-448
 Applications Spec Guide: MS-020-005
 Warranty: SB-1050

Parts Kits

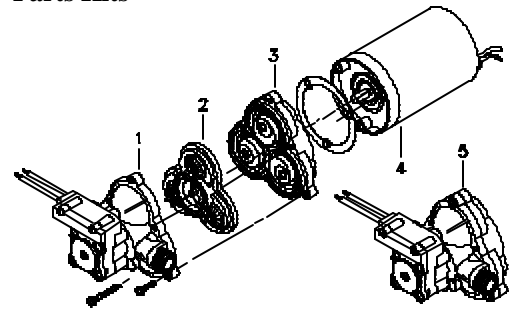

Number	Component	Parts Kit
1	Housing/Switch	94-231-10
2	Valve Assembly	94-232-06
3	Drive Assembly	94-238-04
4	Motor	11-148-06
5	Pump Head	94-236-03
Not Shown	Check Valve	94-237-00



MARINE PRODUCT DATA SHEET

OEM 2088-723-244
 AFTERMARKET 2088-423-244



TYPICAL PERFORMANCE @ 12V DC

PRESSURE		FLOW		CURRENT
BAR	PSI	GPM	LPM	AMPS
0.0	0	2.8	10.2	3.1
0.7	10	2.2	8.3	4.0
1.4	20	1.8	6.9	4.5
2.1	30	1.3	4.9	4.8
2.8	40	0.9	3.4	4.6

— FLOW - - - AMPS

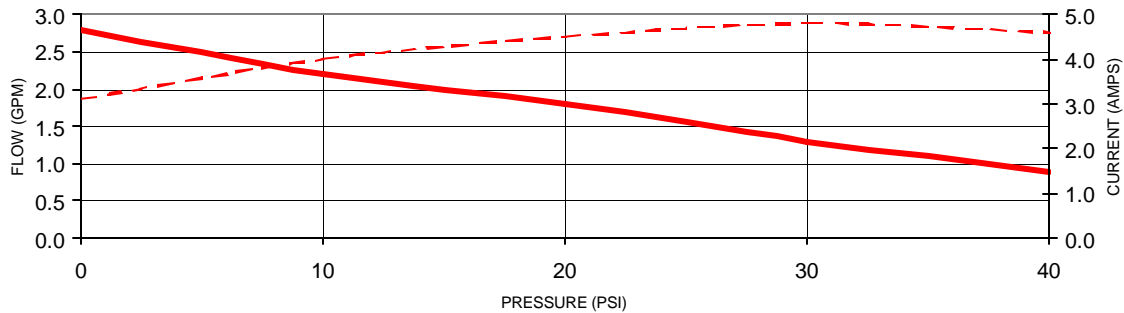

DIMENSIONS [mm]

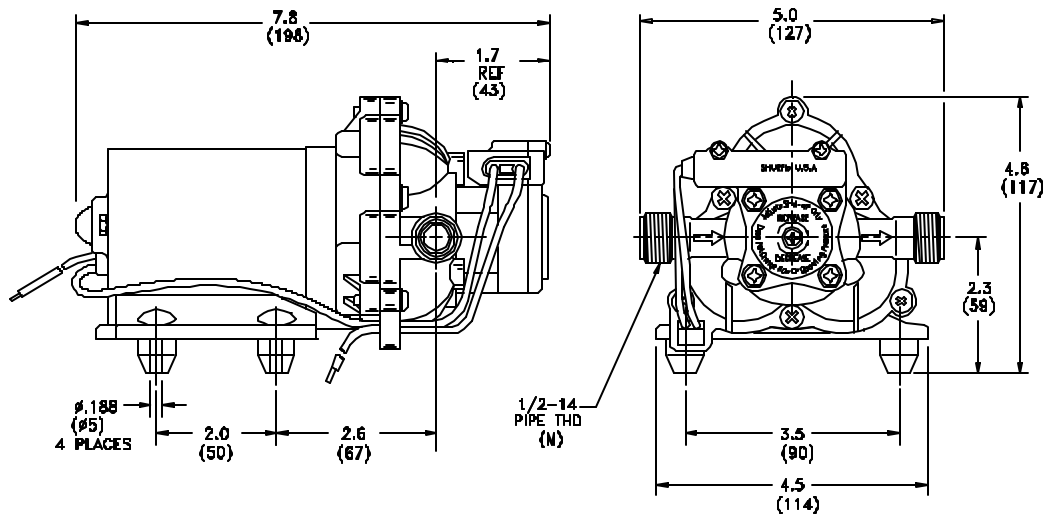

*ISO Registered Facility

SHURflo reserves the right to update specifications, prices, or make substitutions.

SHURflo *
 5900A Katella Ave.
 Cypress, Ca. 90630
 (800) 854-3218 (562) 795-5200
 FAX (562) 795-7554
 Shipping/UPS: 5900C Katella Ave.
 Cypress, Ca. 90630

SHURflo East
 52748 Park Six Court
 Elkhart, IN 46514-5427
 (800) 762-809 (574) 262-0478
 FAX (574) 264-2169
 Http://www.shurflo.com
 © 2001

SHURflo Ltd. *
 Unit 5 Sterling Park
 Gatwick Road, Crawley
 West Sussex, RH10 2QT
 United Kingdom
 +44 1293 424000
 FAX +44 1293 421880

