

# MARINE PRODUCT DATA SHEET

OEM 2088-712-244  
 AFTERMARKET 2088-414-934



## Aqua King Premium



### TYPICAL APPLICATIONS

Multi-fixture marine potable water installations. Other uses may include 12 VDC pressurized water systems in cabins. This pump may be used for general water transfer. For other applications, contact SHURflo.

### PUMP

Type: 3 Chamber Diaphragm  
 Ports: 1/2"-14 NPSM-Male  
 Liquid: 130 °F [54 °C] Max  
 Prime: 6 feet [1.82 M]  
 Inlet PSI: 30 PSI [2.1 Bar] Max  
 Run Dry: Yes

### ELECTRICAL

Motor: 12VDC Permanent Magnet, Continuous Duty (See T-Rise Chart)  
 Protection: Thermal Overload, Automatic Restart  
 Leads: 14 AWG, 36" [40 cm] Red +, 38" [33 cm] Black -  
 Fuse: 15 Amp Recommended  
 Control: Adjustable Switch with Check Valve Shut-Off 45 PSI  
 [3.1 Bar] ± 5 PSI [0.4 Bar]  
 Restart 25 PSI [1.8 Bar] ± 5 PSI [0.4 Bar]

### MATERIALS

Housing: Polypropylene  
 Valves: EPDM  
 Diaphragm: Santoprene  
 Hardware: Stainless Steel

### APPROVALS

UL Marine, Ignition Protected, ISO 8846, c-UL

### WARRANTY

1 Year Limited Warranty  
 See SB-1050 For Full Warranty Details

### SHIPPING

Net Weight (Boxed): 6.6 Lb [3 Kg] each  
 Carton Weight: 6 each, 40 Lb [18 Kg]  
 Carton Size: 24"L x 18"W x 6"H  
 [61cm x 46cm x 15cm]

### RELATED DOCUMENTS

Catalog: MS-030-084  
 Installation Manual: 911-448  
 Maintenance: 911-448  
 Applications Spec Guide: MS-020-005  
 Warranty: SB-1050

### Parts Kits

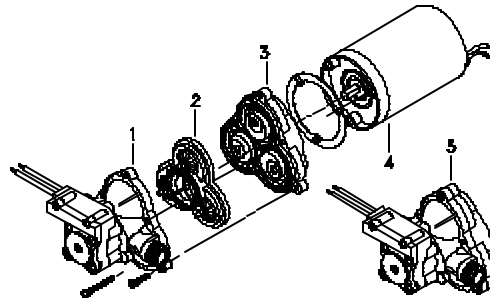

Number	Component	Parts Kit
1	Housing/Switch	94-231-10
2	Valve Assembly	94-232-06
3	Drive Assembly	94-238-03
4	Motor	11-185-06
5	Pump Head	94-236-14
Not Shown	Check Valve	94-237-00



# MARINE PRODUCT DATA SHEET

OEM 2088-712-244  
 AFTERMARKET 2088-414-934



## TYPICAL PERFORMANCE @ 12V DC

PRESSURE		FLOW		CURRENT
BAR	PSI	GPM	LPM	AMPS
0.0	0	3.8	14.3	4.6
0.7	10	3.1	11.7	6.0
1.4	20	2.7	10.2	7.1
2.1	30	2.4	9.0	8.0
2.8	40	2.1	7.9	8.5

## TYPICAL PERFORMANCE @ 12V DC

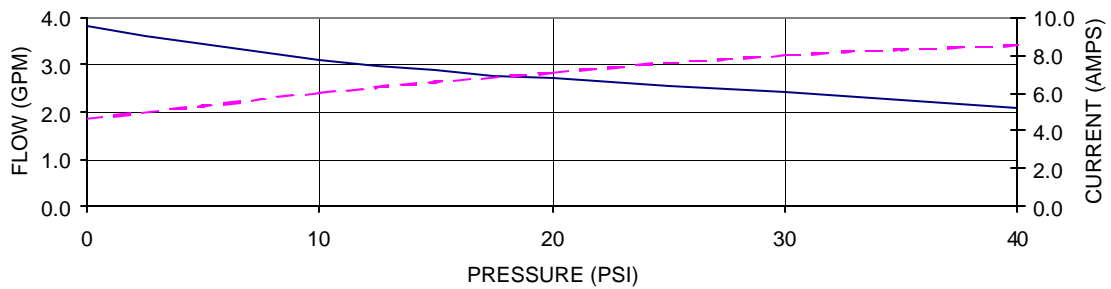

## TYPICAL DIMENSIONS [mm]

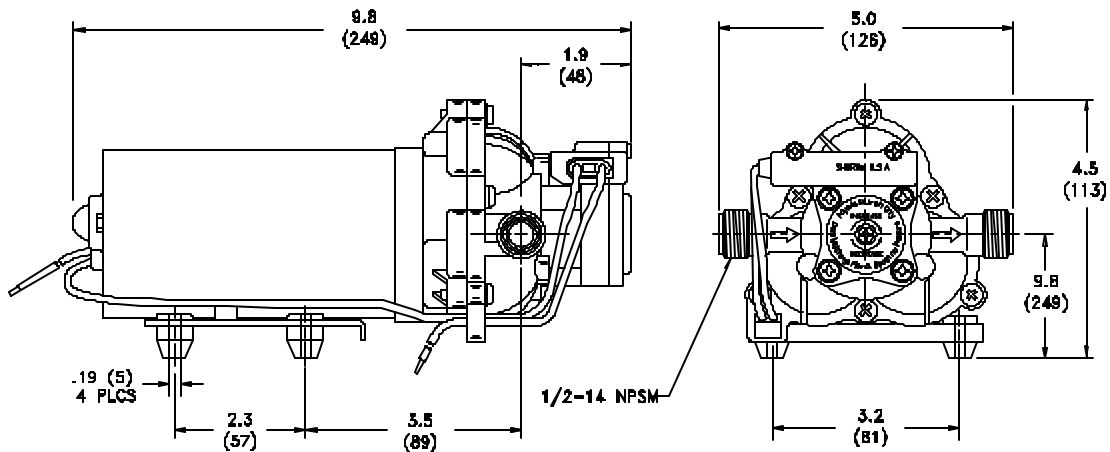

\*ISO Registered Facility

SHURflo reserves the right to update specifications, prices, or make substitutions.

SHURflo \*  
 5900A Katella Ave.  
 Cypress, Ca. 90630  
 (800) 854-3218 (562) 795-5200  
 FAX (562) 795-7554  
 Shipping/UPS: 5900C Katella Ave.  
 Cypress, Ca. 90630

SHURflo East  
 52748 Park Six Court  
 Elkhart, IN 46514-5427  
 (800) 762-809 (574) 262-0478  
 FAX (574) 264-2169  
 Http://www.shurflo.com  
 © 2001

SHURflo Ltd. \*  
 Unit 5 Sterling Park  
 Gatwick Road, Crawley  
 West Sussex, RH10 2QT  
 United Kingdom  
 +44 1293 424000  
 FAX +44 1293 421880

