

MARINE PRODUCT DATA SHEET

OEM 1700-010-030 (800 GPH)
AFTERMARKET 1700-011-030 (800 GPH)



Bait Sentry Livewell Pump



TYPICAL APPLICATIONS

12VC Bait/Livewell Application. For other applications, contact SHURflo.

PUMP

Type:	Centrifugal Pump
Port (Outlet):	3/4" Barb
Port (Inlet):	3/4" NPT-M
Wash Down (Inlet):	1/2" NPT-F
Liquid:	130 °F [54 °C] Max
Prime:	Flooded Inlet
Inlet PSI:	30 PSI [2.1 Bar] Max
Run Dry:	Yes

ELECTRICAL

Motor:	12VDC Permanent Magnet, Continuous Duty
Protection:	External Fuse
Leads:	6 ft (1.8M) Twisted Jacketed Cable
Fuse:	5 Amp Recommended
Control:	No Control

MATERIALS

Housing:	High Strength Nylon
Impeller:	Acetal
Hardware:	Stainless Steel

APPROVALS

Ignition Protected, ISO 8846

WARRANTY

3 Year Limited Warranty
See SB-1050 For Full Warranty Details

SHIPPING

Net Weight (Boxed):	2.5 Lb [1.1 Kg] each
Carton Weight:	14 Lb [6.3 Kg]
Pump in Carton:	6
Carton Size:	16"L x 11"W x 11"H [41 cm x 28 cm x 28 cm]

RELATED DOCUMENTS

Catalog:	MS-030-083 / 030-084
Installation Manual:	911-466
Maintenance:	911-466
Applications Spec Guide:	MS-020-005
Warranty:	SB-1041 / SB-1050

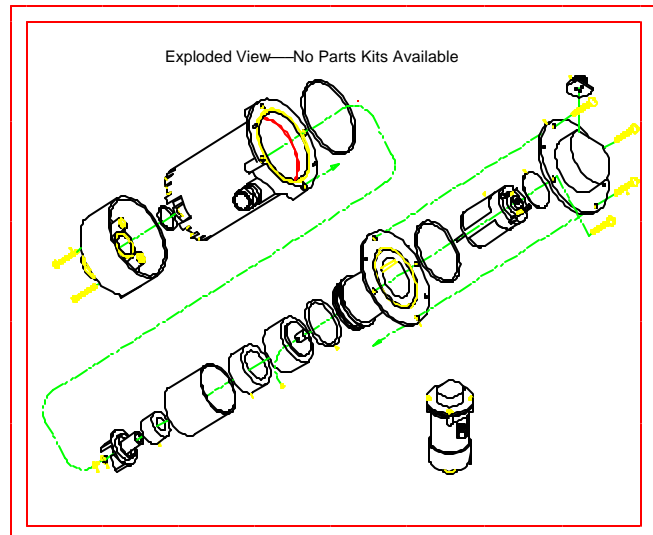

MARINE PRODUCT DATA SHEET

OEM 1700-010-030 (800 GPH)
 AFTERMARKET 1700-011-030 (800 GPH)



TYPICAL PERFORMANCE @ 12V DC

PRESSURE		FLOW		CURRENT
METERS	FT OF HEAD	GPH	LPH	AMPS
0.0	0	800	3028	3.5
1.5	5	390	1476	2.6
2.7	9	0	0	2.2

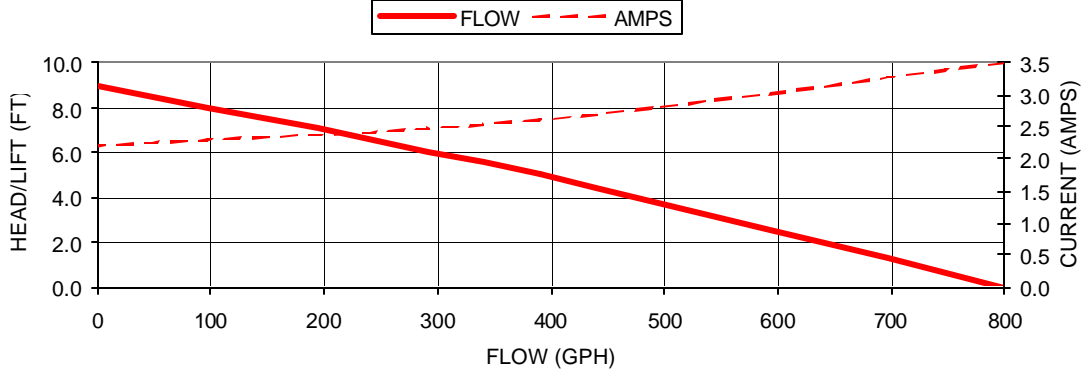

DIMENSIONS [mm]

MODEL: 1700-000-030

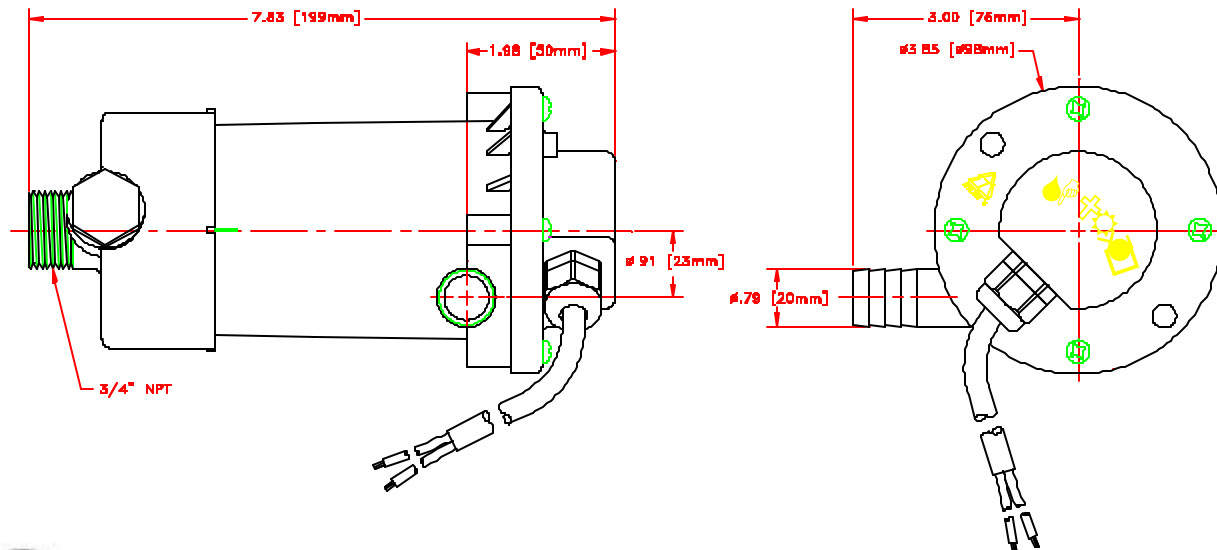

*ISO Registered Facility

SHURflo reserves the right to update specifications, prices, or make substitutions.

SHURflo *
 5900A Katella Ave.
 Cypress, Ca. 90630
 (800) 854-3218 (562) 795-5200
 FAX (562) 795-7554
 Shipping/UPS: 5900C Katella Ave.
 Cypress, Ca. 90630

SHURflo East
 52748 Park Six Court
 Elkhart, IN 46514-5427
 (800) 762-809 (574) 262-0478
 FAX (574) 264-2169
 Http://www.shurflo.com
 ©2001

SHURflo Ltd. *
 Unit 5 Sterling Park
 Gatwick Road, Crawley
 West Sussex, RH10 2QT
 United Kingdom
 +44 1293 424000
 FAX +44 1293 421880

