

# MARINE PRODUCT DATA SHEET

OEM 1700-000-030 (500 GPH)  
AFTERMARKET 1700-001-030 (500 GPH)



## Bait Sentry Livewell Pump



### TYPICAL APPLICATIONS

12V Bait/Livewell Application. For other applications, contact SHURflo.

### PUMP

Type:	Centrifugal Pump
Port (Output):	3/4" Barb
Port (Inlet):	3/4" NPT-M
Wash Down (Inlet):	1/2" NPT-F
Liquid:	130 °F [54 °C] Max
Prime:	Flooded Inlet
Inlet PSI:	30 PSI [2.1 Bar] Max
Run Dry:	Yes

### ELECTRICAL

Motor:	12VDC Permanent Magnet, Continuous Duty
Protection:	External Fuse
Leads:	6 ft (1.8M) Tinned Wires, Twisted Jacketed Cable
Fuse:	2 Amp Recommended
Control:	No Control

### MATERIALS

Housing:	High Strength Nylon
Impeller:	Acetal
Hardware:	Stainless Steel

### APPROVALS

Ignition Protected, ISO 8846

### WARRANTY

3 Year Limited Warranty  
See SB-1050 For Full Warranty Details

### SHIPPING

Net Weight (Boxed):	2.5 Lb [1.1 Kg] each
Carton Weight:	14 Lb [6.3 Kg]
Pumps in carton:	6
Carton Size:	16"L x 11"W x 11"H [41 cm x 28 cm x 28 cm]

### RELATED DOCUMENTS

Catalog:	MS-030-083 / 030-084
Installation Manual:	911-466
Maintenance:	911-466
Applications Spec Guide:	MS-020-005
Warranty:	SB-1041 / SB-1050

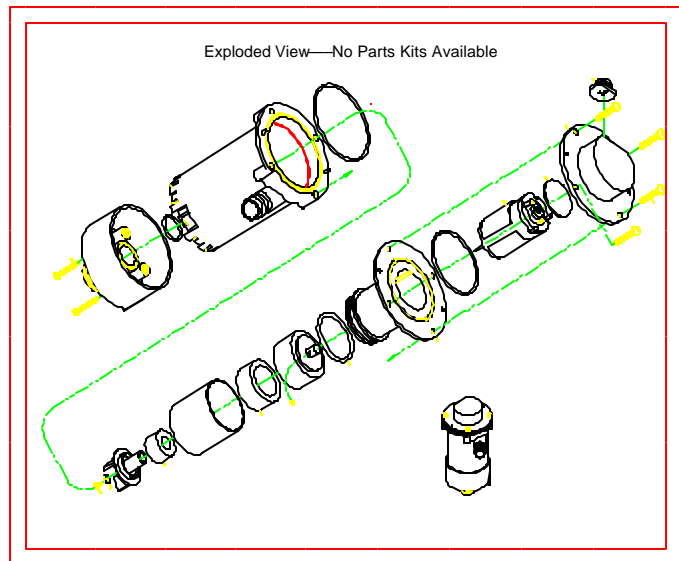

# MARINE PRODUCT DATA SHEET

OEM 1700-000-030 (500 GPH)  
 AFTERMARKET 1700-001-030 (500 GPH)



## TYPICAL PERFORMANCE @ 12V DC

PRESSURE		FLOW		CURRENT
METERS	FT OF HEAD	GPH	LPH	AMPS
0.0	0	500	1892	1.4
0.9	3	289	1093	1.3
1.5	5	0	0	1.1

— FLOW - - - AMPS

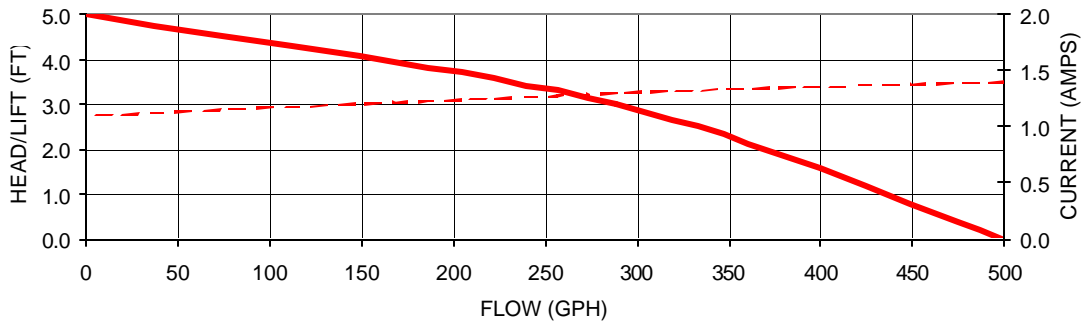

## DIMENSIONS [mm]

MODEL: 1700-000-030

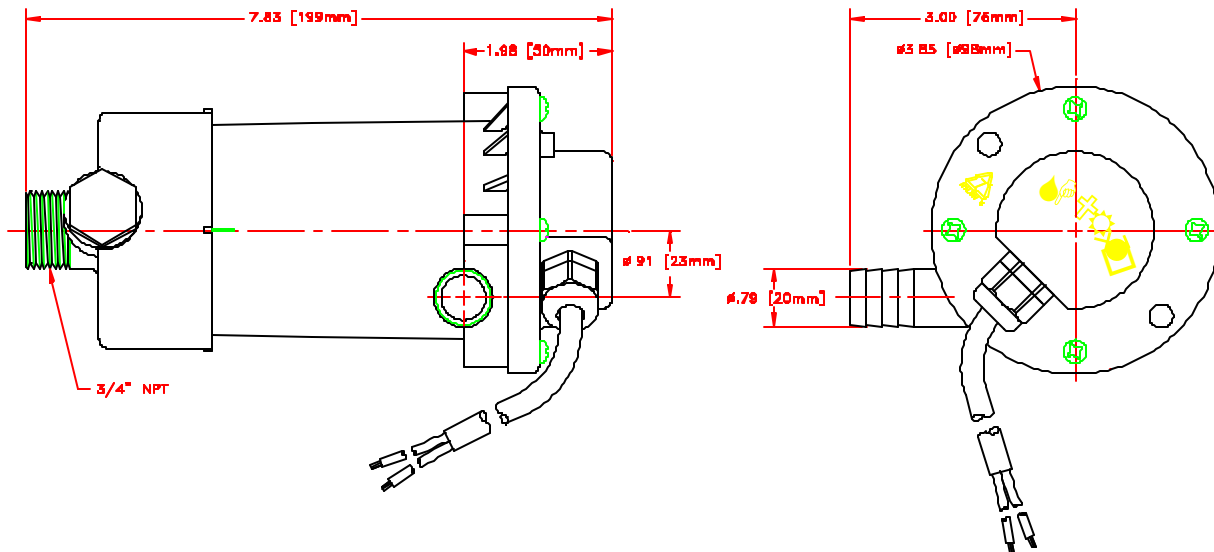

\*ISO Registered Facility

SHURflo reserves the right to update specifications, prices, or make substitutions.

SHURflo \*  
 5900A Katella Ave.  
 Cypress, Ca. 90630  
 (800) 854-3218 (562) 795-5200  
 FAX (562) 795-7554  
 Shipping/UPS: 5900C Katella Ave.  
 Cypress, Ca. 90630

SHURflo East  
 52748 Park Six Court  
 Elkhart, IN 46514-5427  
 (800) 762-809 (574) 262-0478  
 FAX (574) 264-2169  
 Http://www.shurflo.com  
 ©2001

SHURflo Ltd. \*  
 Unit 5 Sterling Park  
 Gatwick Road, Crawley  
 West Sussex, RH10 2QT  
 United Kingdom  
 +44 1293 424000  
 FAX +44 1293 421880

