

MARINE PRODUCT DATA SHEET

OEM 100-000-21
AFTERMARKET 100-009-21

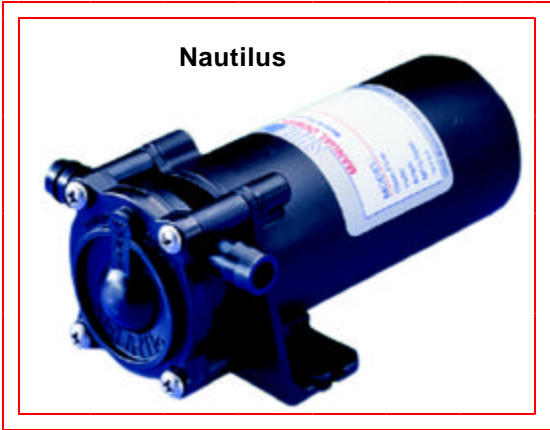

Nautilus

TYPICAL APPLICATIONS

Single fixture 12 VDC Potable water installations. Can be use in combination with electric faucet systems. This pump may also be used for general water transfer. For other applications, contact SHURflo.

PUMP

Type: Wobbler Pump
Ports: 3/8" Barb
Liquid: 130 °F [54 °C] Max
Prime: Flooded Inlet
Inlet PSI: 30 PSI [2.1 Bar] Max
Run Dry: No

ELECTRICAL

Motor: 12VDC Permanent Magnet, Intermittent Duty Splash-proof Housing
Protection: Thermal Overload, Automatic Restart
Leads: 16 AWG, 17" [43 cm] Red (Pos), 17" [43 cm] Black (Neg)
Fuse: 5 Amp Recommended
Control: No Control

MATERIALS

Housing: Ryton
Wobbler: Ryton
Hardware: Stainless Steel

APPROVALS

c-UL

WARRANTY

1 Year Limited Warranty
See SB-1050 For Full Warranty Details

SHIPPING

Net Weight (Boxed): 1 Lb [0.45 Kg] each
Carton Weight: 24 Lb [10.9 Kg]
Pumps in Carton: 24
Carton Size: 14"L x 10"W x 13"H [36 cm x 26 cm x 33 cm]

RELATED DOCUMENTS

Catalog: MS-030-083 / 030-084
Installation Manual: 911-420
Maintenance: 911-420
Application Spec Guide: MS-020-005
Warranty: SB-1041 / SB-1050

Exploded View---No Parts Kits Available

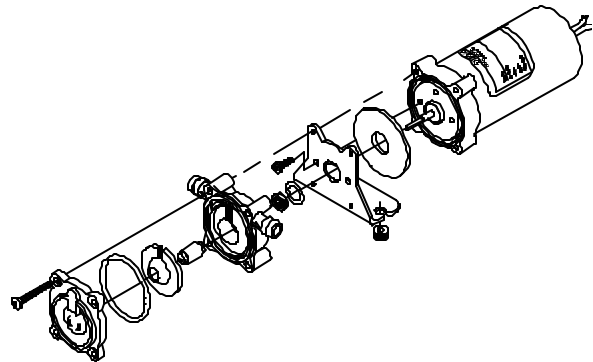

MARINE PRODUCT DATA SHEET

OEM 100-000-21
 AFTERMARKET 100-009-21



TYPICAL PERFORMANCE @ 12V DC

PRESSURE		FLOW		CURRENT
BAR	PSI	GPM	LPM	AMPS
0.0	0	1.0	3.7	1.5
0.4	5	0.7	2.6	1.7
0.7	10	0.3	1.1	2.0
1.0	15	0.0	0.0	2.4

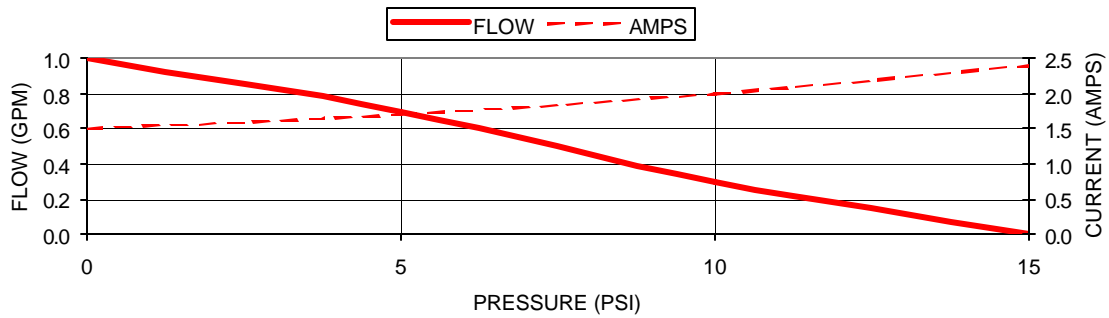

DIMENSIONS [mm]

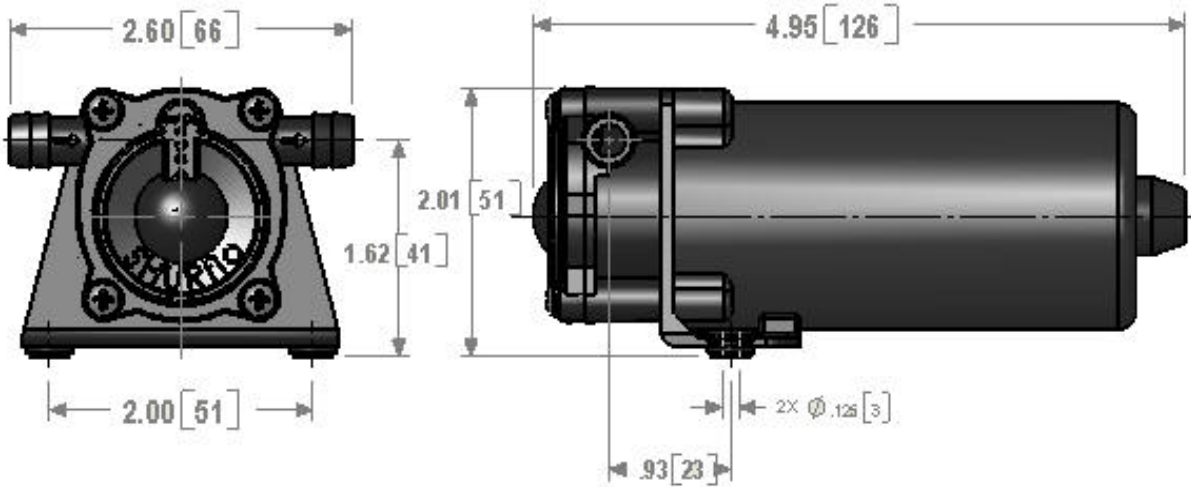

*ISO Registered Facility

SHURflo reserves the right to update specifications, prices, or make substitutions.

SHURflo*
 5900A Katella Ave.
 Cypress, Ca. 90630
 (800) 854-3218 (562) 795-5200
 FAX (562) 795-7554
 Shipping/UPS: 5900C Katella Ave.
 Cypress, Ca. 90630

SHURflo East
 52748 Park Six Court
 Elkhart, IN 46514-5427
 (800) 762-809 (574) 262-0478
 FAX (574) 264-2169
 Http://www.shurflo.com
 © 2001

SHURflo Ltd.*
 Unit 5 Sterling Park
 Gatwick Road, Crawley
 West Sussex, RH10 2QT
 United Kingdom
 +44 1293 424000
 FAX +44 1293 421 880

