

Installation, Operation, Repair, and Parts Manual

12-00

Description

SherTech® "AK" Series Rotary Gear Pumps have a limited self-priming capability and use the simple principle of two gears rotating in a closely fitted housing. These Pumps are a positive displacement type; therefore, with every revolution of the Pump Shaft, a definite amount of liquid is drawn into the Pump through the Suction Port. These Pumps can be used for spraying, recirculating, cleaning, transfer, etc. Liquid temperature range is 20° F to 210° F [-7° C to +99° C] for Models with Buna N Seals, and 40° F to 400° F [4° C to 204° C] for Models with a Viton Seal. Maximum pressure differential is 200 psi [13.8 BAR]. The material being pumped must be compatible with the material used in the Pump's construction.

SherTech® "AK" Series Rotary Gear Pumps are available in bronze and cast iron models featuring, Buna N or Viton Mechanical Seals, Stainless Steel Shafts, Carbon Bushings, Ball Bearings, and an optional Piston Type Regulator Relief Valve which has the capability of relieving internally or externally. Cast Iron Pumps are equipped with Steel Gears. Bronze Pumps are equipped with Bronze Gears.

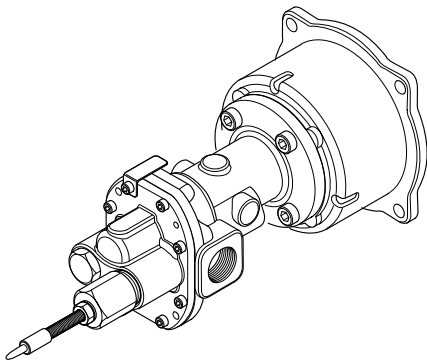

**AMBN1VA, AMBV1VA, AMBN2VA, AMBV2VA,
AMCN1VA, AMCV1VA, AMCN2VA, & AMCV2VA**

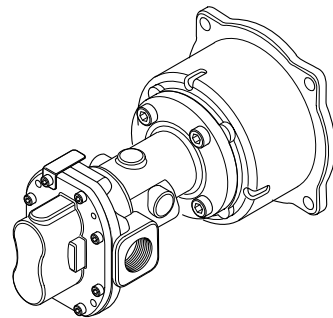

**AMBN1A, AMBV1A, AMBN2A, AMBV2A,
AMCN1A, AMCV1A, AMCN2A, & AMCV2A**

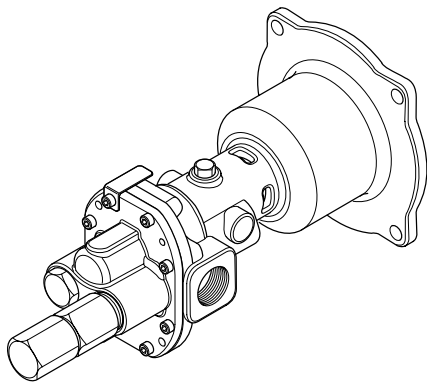

AMCN7VA, AMCV7VA, AMCN11VA, & AMCV11VA

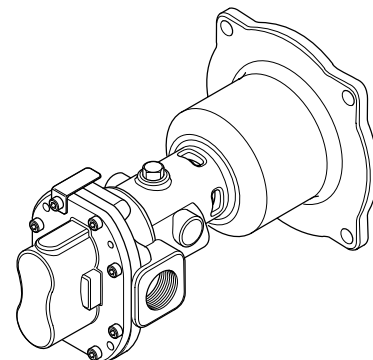

AMCN7A, AMCV7A, AMCN11A, & AMCV11A

General Safety Information

NOTE

Notes are used to notify of installation, operation, or maintenance information that is important but not safety related.

CAUTION

Caution is used to indicate the presence of a hazard, which will or can cause minor injury or property damage if the notice is ignored.

WARNING

Warning denotes that a potential hazard exists and indicates procedures that must be followed exactly to either eliminate or reduce the hazard, and to avoid serious personal injury, or prevent future safety problems with the product.

DANGER

Danger is used to indicate the presence of a hazard that will result in severe personal injury, death, or property damage if the notice is ignored.

DANGER

Do not pump flammable or explosive fluids such as gasoline, fuel oil, kerosene, etc. Do not use in explosive atmospheres. The Pump should only be used with liquids compatible with the Pump materials. Failure to follow this notice can result in severe personal injury and/or property damage and will void the product warranty.

WARNING

The sound pressure level of the Pump may exceed 80 dBA. Observe all safety precautions when operating the Pump within close proximity for extended periods by wearing hearing protectors. Extended exposure to elevated sound levels will result in permanent loss of hearing acuteness, tinnitus, tiredness, stress, and other effects such as loss of balance and awareness.

Make certain that the power source conforms to the requirements of the equipment.

When wiring an electrically driven Pump, follow all electrical and safety codes, plus the most recent National Electrical Code (NEC) and the appropriate Occupational Safety and Health Act (OSHA) requirements.

CAUTION

Do not pump at pressures higher than the maximum recommended pressure.

CAUTION

Provide adequate protection and guarding around the moving parts such as shafts and pulleys.

Disconnect the power before servicing.

Release all pressure within the system before servicing any component.

Drain all liquids from the system before servicing.

Secure the discharge line before starting the Pump. An unsecured discharge line may whip, resulting in personal injury and/or property damage.

Check all hoses for weak or worn condition before each use. Make certain that all connections are tight and secure.

Periodically inspect the Pump and the system components. Perform routine maintenance as required.

Use only pipe, hose, and hose fittings rated for maximum rated pressure of the Pump or the pressure at which the Pressure Relief Valve is set at. Do not use used pipe.

Do not use these Pumps for pumping water or other liquids for human or animal consumption.

Hazardous Substance Alert

1. Always drain and flush the Pump before servicing.
2. Always drain and flush the Pump prior to returning the Pump to the factory for repair.
3. Never store a Pump containing hazardous materials.
4. Prior to returning a Pump for service or repair, drain all liquids and flush the Pump with a neutralizing fluid; then, drain the Pump again, and attach a tag or written notice certifying that this procedure has been done.

NOTE

It is illegal to ship or transport any hazardous chemical without United States Environmental Protection Agency licensing.

Installation

"AK" Series Pump and Motor Assembly

⚠ WARNING

Always disconnect and lock out all power to the "AK" Series Pump motor before performing any service on these units. Failure to do so can result in severe personal injury.

1. Insert the Key into the Motor Shaft Keyway (See Figure 1).
2. Slide the Coupling over the Key and onto the Motor Shaft (See Figure 1).
3. Using the two Set Screws, secure the Coupling to the Motor Shaft (See Figure 1).
4. Lubricate the splines of the Coupling with Never-Seez® equivalent lubricant.
5. Slide the "AK" Series Pump Shaft into the Coupling (See Figure 1).

NOTE

Apply a drop of a blue anaerobic thread-locking compound to all threaded fasteners that do not require lock washers.

6. Using the four Hex. Head Bolts, secure the "AK" Series Pump to the Motor; then, alternately and evenly tighten the four Hex. Head Bolts (See Figure 1).

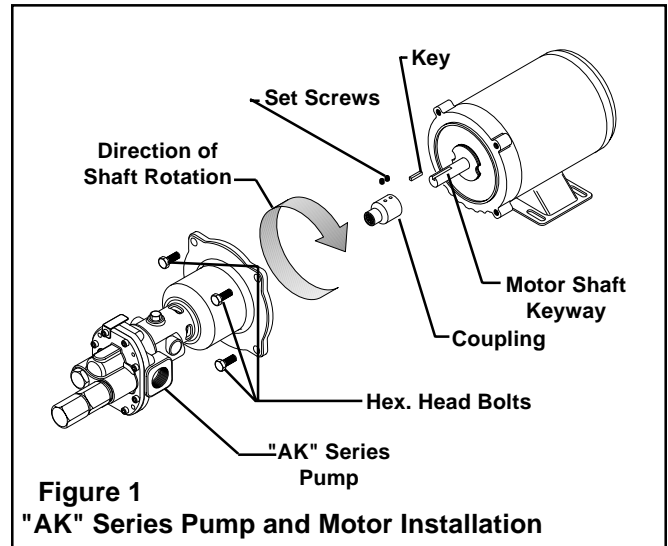

Figure 1
"AK" Series Pump and Motor Installation

"AK" Series Pump Location and Mounting

The "AK" Series Pump is not waterproof, never install it where it may be subject to extreme humidity or possible immersion in any liquid. Always locate the "AK" Series Pump in an area where it is protected from the weather and extremes of heat, cold, and humidity.

Ambient temperatures around the "AK" Series Pump should not exceed 104° F [40° C].

For outdoor installations, the "AK" Series Pump must be protected by a cover that will not restrict the flow of air around the motor.

Support the "AK" Series pump and piping during and after installation. Failure to do so may cause the piping to break, the Pump to fail, or Bearing failures, etc.. All of which can result in personal injury and/or property damage.

Always mount the "AK" Series Pump on a solid foundation and secure it with the appropriate fasteners.

Piping

All piping must be supported to minimize the forces exerted by the "AK" Series Pump. The supports must be capable of supporting the weight of the pipe and the fluid being pumped. Flexible joints can be used to minimize the transmission of mechanical vibration caused by the "AK" Series Pump.

NOTE

If plastic or fabric hose is used for the Suction Line, it should be of a reinforced type so it will not collapse under suction. The Suction and Discharge Lines should be equal to or greater than the port sizes.

The "AK" Series Pump is self priming; however, when pumping low viscosity fluid under Suction Lift (when liquid is below the Pump), Hypro recommends the installation of a Foot Valve on the inlet side or a Check Valve on the outlet side to keep the Inlet Line full and prolong the life of the "AK" Series Pump (See Figure 2).

With Flooded Inlet Installations (when the liquid is above the Pump) a Check Valve on the outlet side eliminates back-flow, and reduces differential pressure that the "AK" Series Pump must supply to start fluid flow (See Figure 3).

Inlet Side Strainers or Traps can be used to prevent damage to the "AK" Series Pump from foreign material. Use only Strainers and Traps that will not restrict the inlet, resulting in cavitation and fluid stoppage.

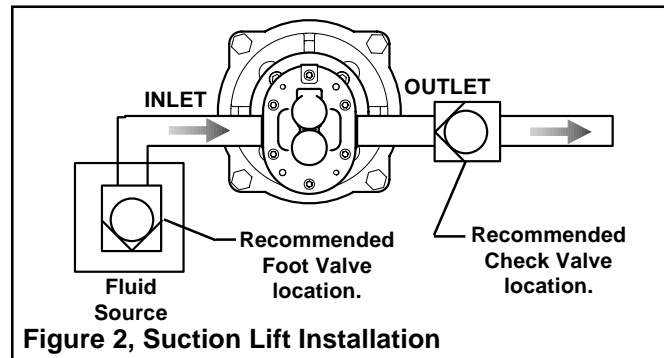

Figure 2, Suction Lift Installation

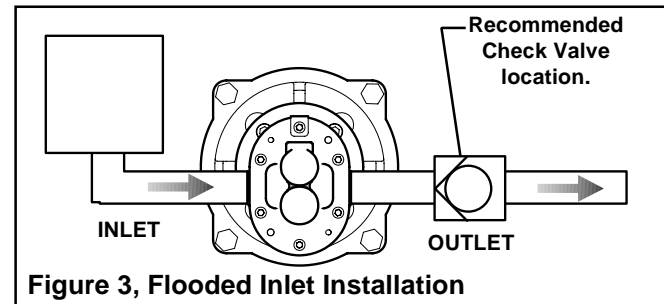

Figure 3, Flooded Inlet Installation

NOTE

Whenever possible, install Pressure and Vacuum Gauges. Pressure and Vacuum Gauges provide information on the following:

- Normal or abnormal pressure.
- Flow indication.
- Variations in system conditions.
- Variations in fluid viscosity.
- Overload conditions.

Electrical Connections

CAUTION

Make sure the power source conforms to the requirements of the equipment being installed.

When wiring an electrically driven pump, follow electrical and safety codes, including the most current National Electrical Code (NEC) and the Occupational Safety and Health Act (OSHA) requirements in the United States.

WARNING

To reduce the risk of electric shock, all motors must be adequately grounded to a grounded metal raceway system, or by using a separate grounding wire connected to the bare metal on the motor frame, or to the grounding screw located inside the motor terminal box. Refer to the National Electric code (NEC), Article 250 (grounding) for further information.

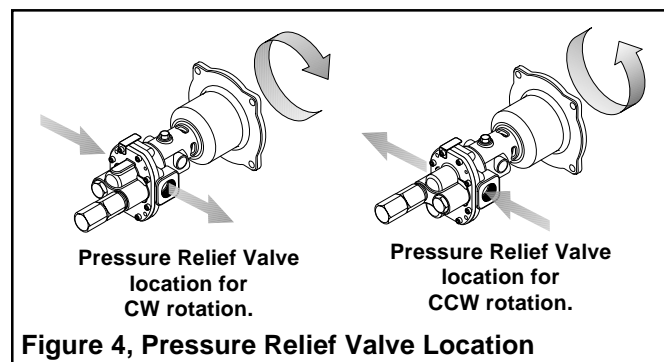

Figure 4, Pressure Relief Valve Location

1. Make all electrical connections according to the instructions provided with the Motor.
2. After making all the electrical connections, jog the Motor momentarily to verify correct shaft rotation as shown in Figure 4.

Operation

In order to safely use the Pump; familiarize yourself with this Pump and with the liquid (chemical, etc.) that is pumped through it. This Pump is not suitable for many liquids.

The "AK" Series Pump is capable of self priming up to 6 ft. lift when dry; however, this is not recommended because it may result in premature Seal and/or Pump failure. A pump with lubricated Gears is capable of a 10 ft. vertical lift. To facilitate priming and Pump longevity in suction lift applications, install a recommended Check Valve as shown in Figure 5.

If a Foot Valve or Check Valve is not used in the suction line, it may be necessary to refill the Pump every time the unit is stopped and you wish to restart the Pump. This depends on the length of time between starts and whether the Gears are wet enough to close all cavities to allow a prime.

NOTE

For proper component lubrication, the flow rate should be at least 10% of the rated capacity of the Pump at a given rpm.

NOTE

On size 7 and 11 "AK" Series Pumps, remove the 1/8 NPT Pipe Plug and fill the seal cavity with the operating fluid or a neutral fluid; then, reinstall the 1/8 NPT Plug (See Figure 6).

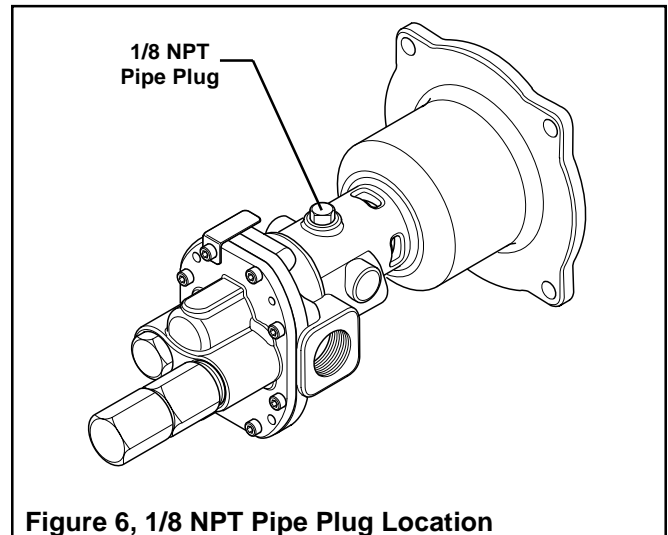
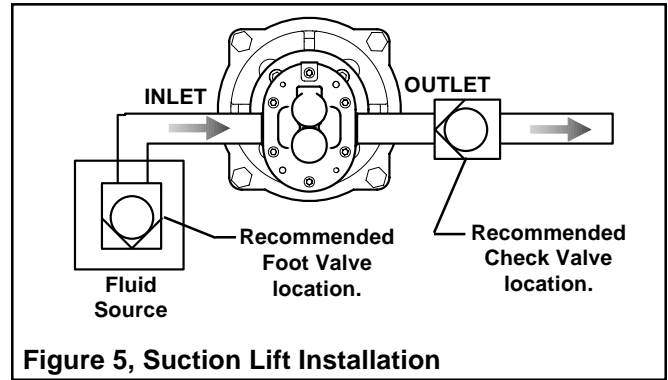

Pump Shaft Rotation

"AK" Series Pumps without Relief Valve are bidirectional and can have clockwise or counterclockwise Shaft rotation depending on the desired discharge location (See Figure 7).

"AK" Series Pump equipped with the Optional Relief Valve are factory assembled with the Relief Valve located as standard on the right side of the Pump cover when viewed from the front of the Pump. This configuration requires a clockwise Shaft rotation when viewed from the front of the Pump or Motor. To operate the Pump in reverse direction, the Cover must be rotated 180 degrees (See Figure 8).

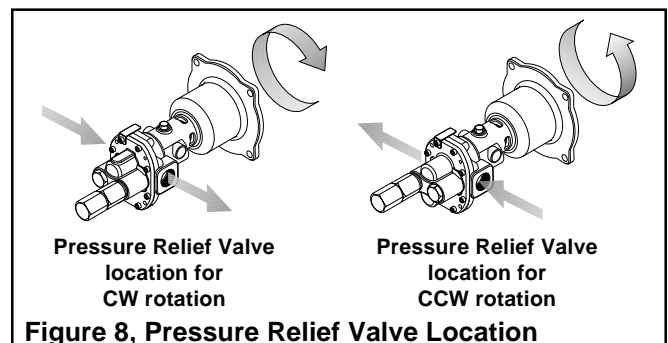
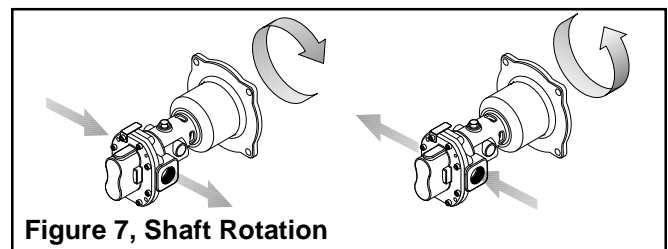

Optional Pressure Relief Valve

The Optional Pressure Relief Valve is intended to be used as a system relief valve to prevent Pump and Motor damage that can occur when the discharge line is closed. This Pressure Relief Valve is not factory set. Extended operation (over one minute) under shut-off conditions may cause the Pump to overheat, leak, or damage itself.

To change the Relief Valve pressure setting, remove the Cap; then, loosen the Lock Nut (See Figure 9). Turn the Adjusting Valve Stem clockwise to increase the pressure setting or counterclockwise to reduce the pressure setting (See Figure 9).

The Pressure Relief Valve can be converted from a standard Internal Relief Valve to an External Relief Valve. Remove the NPT Pipe Plug from the Cover Plate (See Figure 10). Insert a Set Screw (supplied with the Pump) into the tapped hole. The open port must now be piped back to the fluid source or upstream of the Pump suction.

NOTE

Apply a drop of a blue anaerobic thread-locking compound to all threaded fasteners that do not require lock washers.

NOTE

The Pressure Relief Valve must be on the discharge side of the Pump (See Figure 11). To change the location of the Pressure Relief Valve, remove the Socket Head Cap Screws and rotate the entire Pump Cover and Pressure Relief Valve 180 degrees. Then, reinstall and alternately and evenly tighten the Socket Head Cap Screws 66 in. lbs. [7.4 Nm] torque.

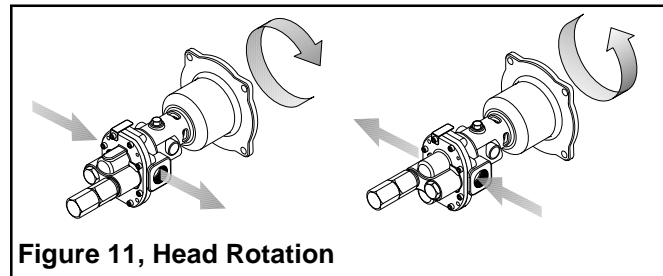
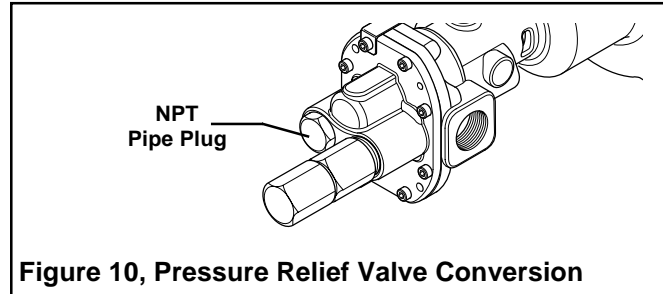
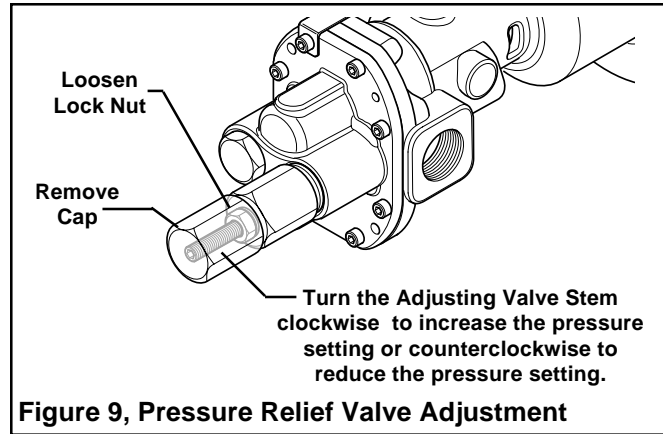

Troubleshooting

Problem	Probable Cause(s)	Solution
Pump will not prime or retain prime after operating.	Pump is not primed.	Prime the Pump.
	Air leak in Suction Line.	Seal leaks in Suction Line.
	Worn Gears.	Replace Gears.
	Clogged Foot Valve, Strainer, or Filter.	Clear Foot Valve, Strainer, or Filter of debris or foreign material.
	Suction lift too far.	Shorten lift and piping, or install a Foot or Check Valve and prime the Pump.
Flow rate is low.	Incorrect speed.	Check drive.
	Piping is fouled or damaged.	Clean or replace the piping.
	Worn Gears.	Replace Gears.
	Discharge line restricted or undersized.	Flush out or replace the discharge line.
Pump runs but does not pump fluid.	Pump is not primed.	Prime the Pump.
	Faulty suction piping.	Replace the suction piping.
	Pump located too far from the fluid source.	Relocate the Pump closer to the fluid source.
	Closed Gate or Check Valve.	Open the Gate or Check Valve.
	Clogged Foot Valve, Strainer, or Filter.	Clear Foot Valve, Strainer, or Filter of debris or foreign material.
	Suction lift too far.	Shorten lift and piping, or install a Foot or Check Valve and prime the Pump.
	Gear loose on the Shaft.	Replace the Gears and Shafts.
Pressure is low.	Incorrect motor size and speed.	Replace the motor with one of the correct size and speed.
	Discharge Line restricted or undersized.	Flush out or replace the Discharge Line.
	Worn Gears.	Replace the Gears and Shafts.
Pump starts and stops pumping.	Fouled Gears.	Replace the Gears and Shafts.
	Air leak in Suction Line or Foot Valve.	Seal leaks in Suction Line or Foot Valve.
Excessive noise when the Pump is in operation.	Improper installation.	Place a rubber pad under the Pump Base to reduce noise level.
	Pump not secured to a firm foundation.	Properly secure the Pump.
	Worn Gears.	Replace the Gears and Shafts.
	Piping not properly supported.	Make necessary adjustments to properly support the piping.
	Restricted Suction Line.	Remove restrictions from the Suction Line.

Parts Replacement

AMBN1VA, AMBV1VA, AMBN1A, AMBV1A, AMBN2VA, AMBV2VA, AMBN2A, AMBV2A, AMCN1VA, AMCV1VA, AMCN1A, AMCV1A, AMCN2VA, AMCV2VA, AMCN2A, & AMCV2A

Disassembly

⚠ WARNING

Disconnect and lock out all power sources when performing any service on the Pump or any item used in connection with the Pump. Failure to do so could result in personal injury or property damage.

NOTE

"AK" Series Pumps XXXXXVA have an optional Pressure Relief Valve on the Cover.

1. Remove the four Hex. Head Bolts securing the "AK" Series Pump to the Motor; then, slide the "AK" Series Pump off the Motor Shaft and Coupling (See Figure 12).
2. Remove the Screws securing the Cover from the Gear Pump Body and Adapter. Do not remove the Pressure Relief Valve from the Cover on Models thus equipped (See Figure 13).
3. Remove and discard the O-ring from the Gear Pump Body and Adapter (See Figure 13).
4. Slide the Idler Shaft/Gear Assembly out of the Pump Body and Adapter (See Figure 13).
5. Slide the Drive Gear off the Drive Shaft (See Figure 13).

⚠ WARNING

Special attention should be exercised when working with retaining rings. Always wear protective goggles when working with spring or tension loaded fasteners or devices.

6. Remove the Internal Retaining Ring from the back of the Gear Pump Body (See Figure 14).
7. Press the Drive Shaft, Bearing, Seal, and Seat out of the Gear Pump Body and Adapter in the direction indicated (See Figure 14).
8. Remove the External Retaining Ring (A) from the Drive Shaft; then, slide the Seal, Seat, large Washer, and small Washer off the Drive Shaft in the direction indicated (See Figure 15).
9. Remove the External Retaining Ring (C); then, press the Bearing off the Drive Shaft in the direction shown (See Figure 15).
10. Inspect the Drive Shaft, Idler Shaft, and Gears for signs of wear or damage. If they show signs of wear or damage the Gears and Shafts must be replaced as a set.

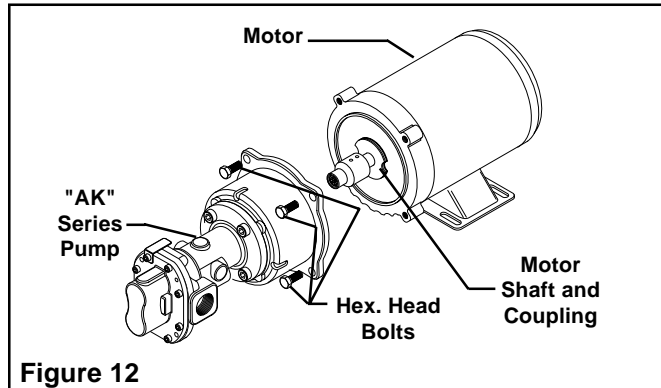

Figure 12

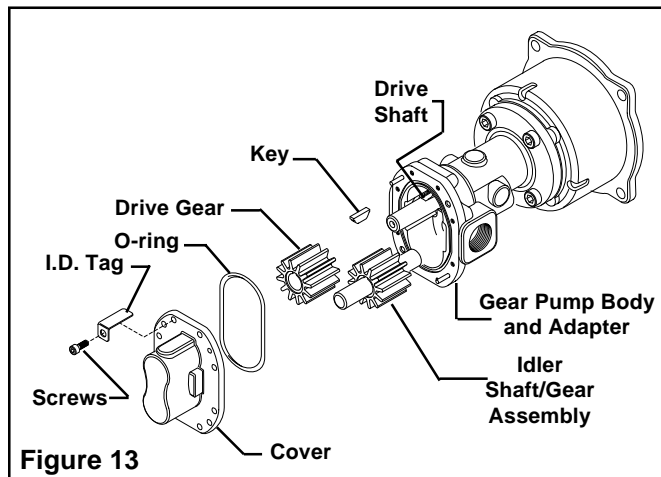

Figure 13

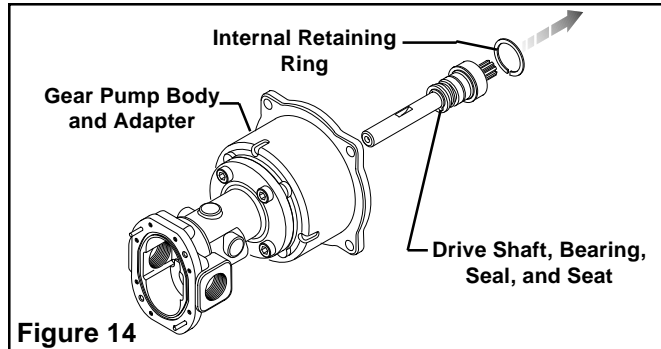

Figure 14

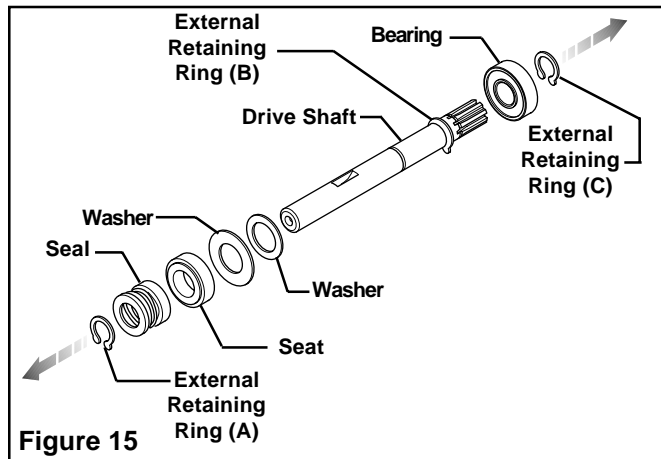

Figure 15

Reassembly

NOTE

Always support the inner bearing race when pressing a new Bearing onto a Shaft.

1. Press the new Bearing onto the Drive Shaft until it is against the External Retaining Ring (B); then, install External Retaining Ring (C) (See Figure 16).
2. Slide the Small Washer, Large Washer, Seat, and Seal onto the Drive Shaft; then install External Retaining Ring (A) (See Figure 16).
3. Supporting the outer bearing race, press the new Drive Shaft, Bearing, Washers, Seat, and Seal into the Gear Pump Body and Adapter (See Figure 17).
4. Install the Internal Retaining Ring at the back of the Gear Pump Body and Adapter (See Figure 17).
5. Insert the Key into the Drive Shaft; then, slide the Drive Gear onto the Drive Shaft (See Figure 18)
6. Slide the Idler Shaft/Gear Assembly into the Bushing located in the Gear Pump Body and Adapter (See Figure 18).
7. Install a new O-ring into the o-ring groove of the Gear Pump Body and Adapter (See Figure 18)

NOTE

Apply a drop of a blue anaerobic thread-locking compound to all threaded fasteners that do not require lock washers.

8. Place the Cover on the Gear Pump Body and Adapter and secure it to the Gear Pump Body and Adapter using the six Screws (See Figure 18).
9. Alternately and evenly, tighten the six Screws to 66 In. Lbs. [7.4 Nm] torque.
10. Lubricate the splines of the Coupling with Never-Seez® equivalent lubricant (See Figure 19).
11. Slide the "AK" Series Pump Shaft into the Coupling (See Figure 19).
12. Using the four Hex. Head Bolts, secure the "AK" Series Pump to the Motor; then, alternately and evenly tighten the four Hex. Head Bolts (See Figure 19).

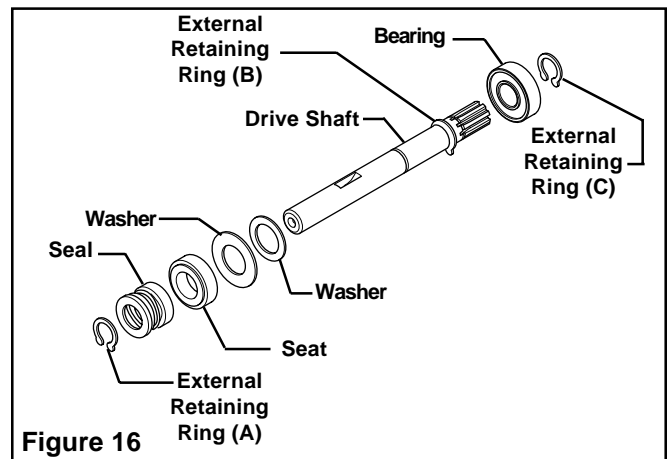

Figure 16

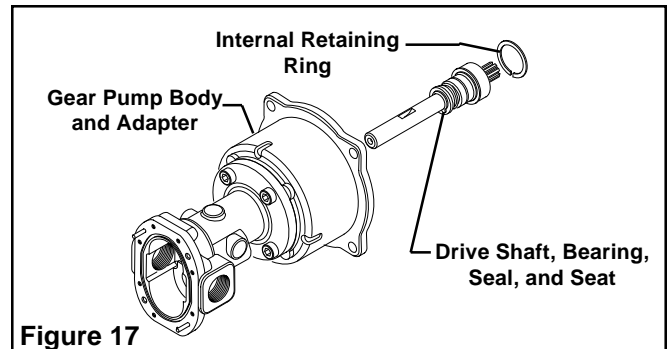

Figure 17

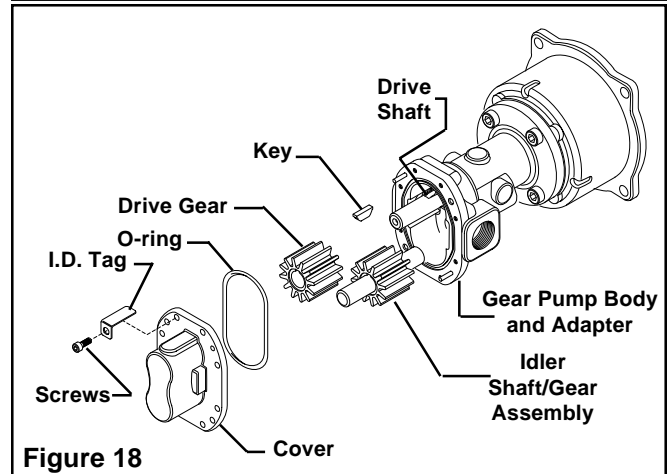

Figure 18

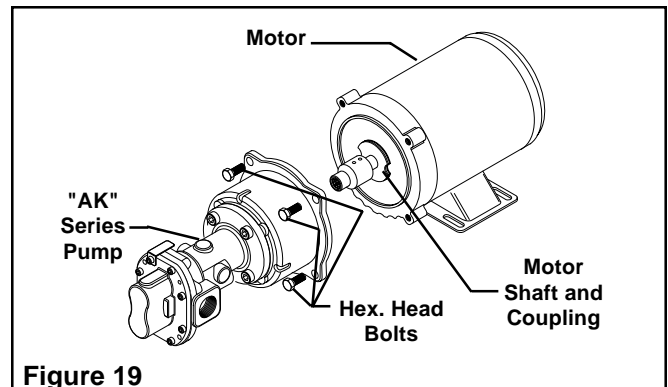

Figure 19

Disassembly

⚠ WARNING

Disconnect and lock out all power sources when performing any service on the Pump or any item used in connection with the Pump. Failure to do so could result in personal injury or property damage.

NOTE

"AK" Series Pumps XXXXXVA have an optional Pressure Relief Valve on the Cover.

1. Remove the four Hex. Head Bolts securing the "AK" Series Pump to the Motor; then, slide the "AK" Series Pump off the Motor Shaft and Coupling (See Figure 20).
2. Remove the Screws securing the Cover from the Gear Pump Body. Do not remove the Pressure Relief Valve from the Cover on Models thus equipped (See Figure 21).
3. Remove and discard the O-ring from the Gear Pump Body (See Figure 21).
4. Slide the Idler Gear and the Idler Shaft out of the Pump (See Figure 21).

⚠ CAUTION

Special attention should be exercised when working with retaining rings. Always wear protective goggles when working with spring or tension loaded fasteners or devices.

5. Remove the External Retaining Ring; then, slide the Gear off the Idler Shaft (See Figure 21).
6. Slide the Drive Gear off the Drive Shaft (See Figure 21).
7. Remove the Internal Retaining Ring from the back of the Gear Pump Body (See Figure 22).
8. Press the Drive Shaft, Bearing, Seal, O-ring, and Retainer out of the Gear Pump Body in the direction indicated (See Figure 22).
9. Remove and discard the O-ring from the inside of the Gear Pump Body (See Figure 22).
10. Remove the External Retaining Ring (A); then, remove the Seal, Seat, and Retainer from the Drive Shaft in the direction shown (See Figure 23).
11. Remove the External Retaining Ring (C); then, press the Bearing off the Drive Shaft in the direction shown (See Figure 23).
12. Inspect the Drive Shaft, Idler Shaft, and Gears for signs of wear or damage. If they show signs of wear or damage the Gears and Shafts must be replaced as a set.

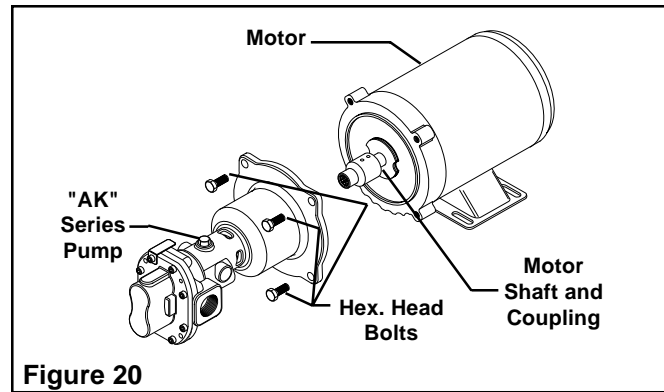

Figure 20

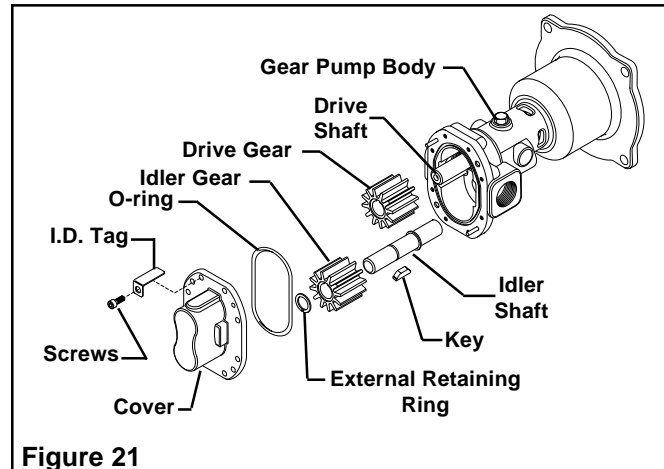

Figure 21

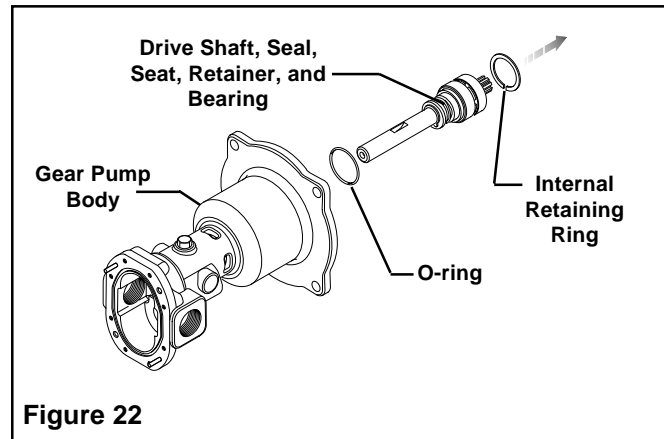

Figure 22

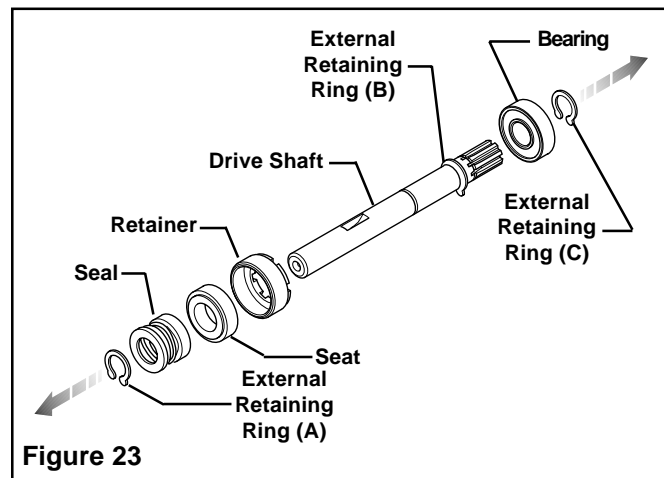

Figure 23

Reassembly

NOTE

Always support the inner bearing race when pressing a new Bearing onto a Shaft.

1. Press the new Bearing onto the Drive Shaft until it is against the External Retaining Ring (B); then, install External Retaining Ring (C) (See Figure 24).
2. Slide the Retainer, Seat, and Seal onto the Drive Shaft; then, install the External Retaining Ring (A) (See Figure 24).
3. Install a new O-ring into the Gear Pump Body (See Figure 25).
4. Supporting the outer bearing race, press the new Bearing, Retainer, Seat, and Seal into the Gear Pump Body and Adapter (See Figure 25).
5. Install the Internal Retaining Ring at the back of the Gear Pump Body (See Figure 25).
6. Insert the Key into the Drive Shaft; then, slide the Drive Gear onto the Drive Shaft (See Figure 26)
7. Slide the Idler Gear onto the Idler Shaft (See Figure 26).
8. Install the External Retaining Ring securing the Idler Gear to the Idler Shaft (See Figure 26).
9. Slide the Idler Shaft and Idler Gear into the Bushing located in the Gear Pump Body (See Figure 26).
10. Install a new O-ring into the o-ring groove of the Gear Pump Body (See Figure 26)

NOTE

Apply a drop of a blue anaerobic thread-locking compound to all threaded fasteners that do not require lock washers.

11. Place the Cover on the Gear Pump Body and secure it to the Gear Pump Body using the six Screws (See Figure 27).
12. Alternately and evenly, tighten the six Screws to 66 In. Lbs. [7.4 Nm] torque.
13. Lubricate the splines of the Coupling with Never-Seez® equivalent lubricant (See Figure 27).
14. Slide the "AK" Series Pump Shaft into the Coupling (See Figure 27).
15. Using the four Hex. Head Bolts, secure the "AK" Series Pump to the Motor; then, alternately and evenly tighten the four Hex. Head Bolts (See Figure 27).

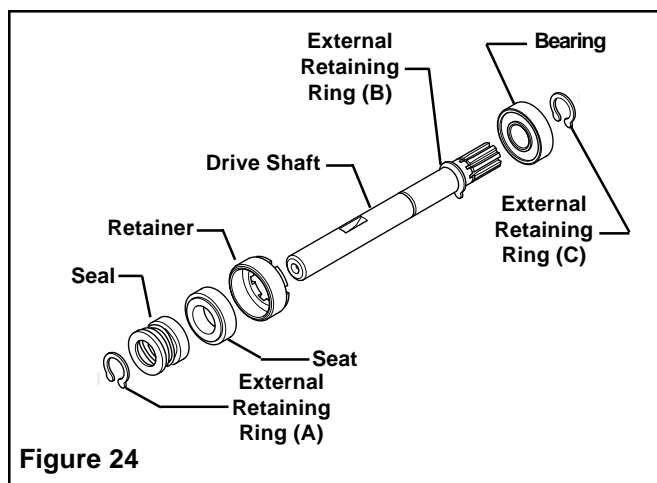

Figure 24

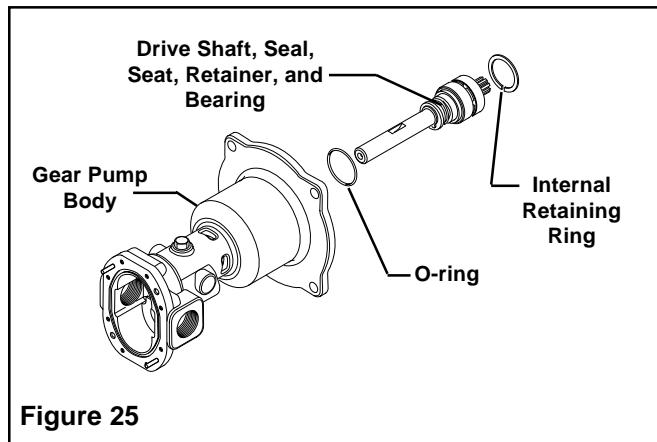

Figure 25

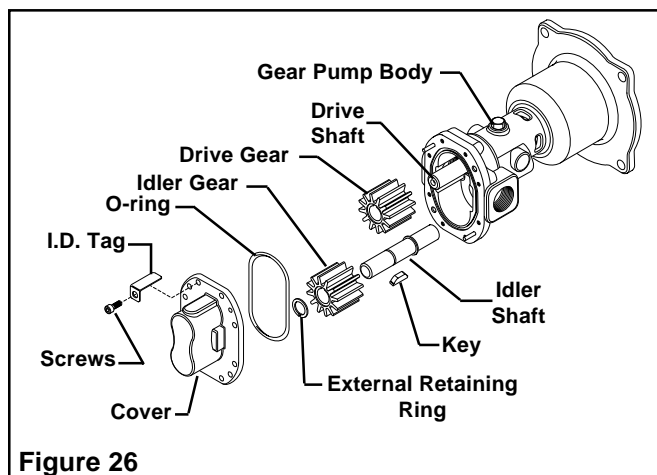

Figure 26

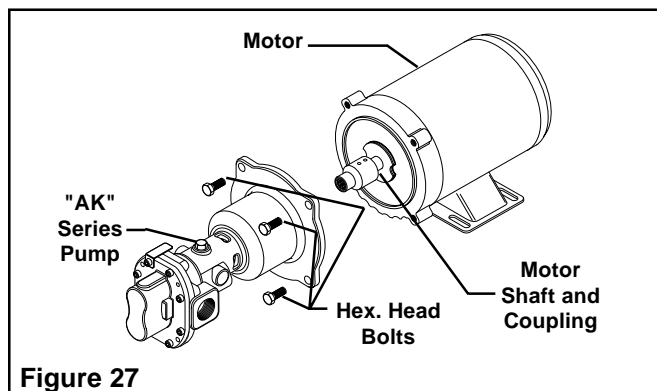

Figure 27

Model Identification Codes and Options

Example: **AMCV7VA4T**

(1) A (2) M (3) C (4) V (5) 7 (6) V (7) A (8) 4 (9) T

1st Series	2nd Mounting	3rd Material	4th Seal (Mech)	5th Gear:Port Size	6th Options	7th Brackets	8th Motor Mounted Only HP	9th Type
A:AK Series	M: Motor Mounted	C: Cast Iron *B: Bronze	N: Buna N V: Viton	1: 1/8" 2: 1/2" 7: 3/4" 11: 3/4"	V: Relief Valve	A: 56C B: 56C/145TC	1: 1/3 2: 1/2 3: 3/4 4: 1 5: 1-1/2 6: 2	"Blank"; = no code single phase ODP motor 3: 3 Phase ODP T: 1 Phase TEFC 3T: 3 Phase TEFC
<small>* Size 7 and 11 gear pumps available only in cast iron. NOTE: Maximum motor speed is 1725 RPM.</small>								

ODP and TEFC Phase Replacement Motors

ODP and TEFC Phase Replacement Motors								
HP	Motor Suffix	1 Phase ODP P/N	Motor Suffix	3 Phase ODP P/N	Motor Suffix	1 Phase TEFC P/N	Motor Suffix	3 Phase TEFC P/N
1/3	1	22151	13	N/A	1T	23128	13T	N/A
1/2	2	21721	23	N/A	2T	22601	23T	N/A
3/4	3	21722	33	N/A	3T	22574	33T	N/A
1	4	22154	43	23130	4T	22572	43T	22147
1 - 1/2	5	22155	53	23131	5T	23126	53T	22148
2	6	N/A	63	23133	6T	23132	63T	22149
3	7	N/A	73	23136	7T	N/A	73T	22150

Parts List

(AMBN1VA, AMBV1VA, AMBN2VA, AMBV2VA, AMCN1VA, AMCV1VA, AMCN2VA, AMCV2VA)

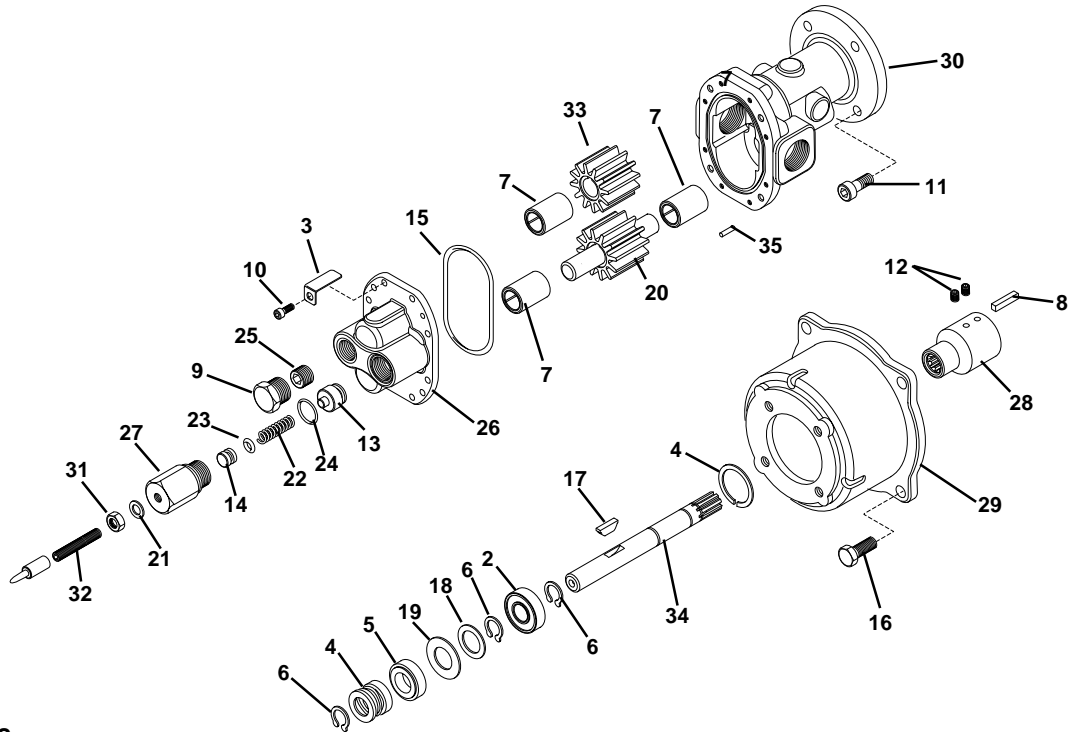

Figure 28

REF. NO.	DESCRIPTION	PART NUMBER BY MODEL								QTY
		AMBN1VA	AMBV1VA	AMBN2VA	AMBV2VA	AMCN1VA	AMCV1VA	AMCN2VA	AMCV2VA	
1	Retaining Ring	04303	04303	04303	04303	04303	04303	04303	04303	1
2	Ball Bearing	04306	04306	04306	04306	04306	04306	04306	04306	1
3	I.D. Tag	13285	13285	13285	13285	13285	13285	13285	13285	1
4 ¹	Seal	10522	12325	10522	12325	10522	12325	10522	12325	1
5 ¹	Seat	18932	19277	18932	19277	18932	19277	18932	19277	1
6	Retaining Ring	21093	21093	21093	21093	05484	05484	05484	05484	3
7	Carbon Bushing	21332	21332	21332	21332	21332	21332	21332	21332	3
8	Key	21437	21437	21437	21437	21437	21437	21437	21437	1
9	Pipe Plug	21705	21705	21705	21705	21409	21409	21409	21409	1
10	10-24 Hex. Hd. Screw	21916	21916	21916	21916	21916	21916	21916	21916	6
11	Screw	21994	21994	21994	21994	21994	21994	21994	21994	4
12	1/4- 20 Set Screw	22161	22161	22161	22161	22161	22161	22161	22161	2
13	Piston	22593	22593	22593	22593	22593	22593	22593	22593	1
14	Retainer	22595	22595	22595	22595	22595	22595	22595	22595	1
15	O-ring	22626	22684	22626	22684	22626	22684	22626	22684	1
16	Hex. Hd. Screw	22771	22771	22771	22771	22771	22771	22771	22771	4
17	Key	22894	22894	22894	22894	22894	22894	22894	22894	1
18	Washer	22896	22896	22896	22896	22896	22896	22896	22896	1
19	Washer	22897	22897	22897	22897	22897	22897	22897	22897	1
20	Idler Shaft/Gear Assembly	23778	23778	23881	23881	23882	23882	23883	23883	1
21	Washer	22934	22934	22934	22934	22934	22934	22934	22934	1
22	Spring	22935	22935	22935	22935	22935	22935	22935	22935	1
23	O-ring	22936	22594	22936	22594	22936	22594	22936	22594	1
24	O-ring	22937	22600	22937	22600	22937	22600	22937	22600	1
25	Set Screw	22938	22938	22938	22938	22938	22938	22938	22938	1
26	Cover	22953	22953	22953	22953	23488	23488	23488	23488	1
27	Relief Valve Cap	22954	22954	22954	22954	22596	22596	22596	22596	1
28	Spline Coupling	23102	23102	23102	23102	23102	23102	23102	23102	1
29	Adapter	23260	23260	23260	23260	23260	23260	23260	23260	1
30	Gear Pump Body	23294	23294	23295	23295	23485	23485	23486	23486	1
31	Jam Nut	23408	23408	23408	23408	23408	23408	23408	23408	1
32	Set Screw	23410	23410	23410	23410	23410	23410	23410	23410	1
33	Gear	23412	23412	23407	23407	22893	22893	23511	23511	1
34	Drive Shaft	23450	23450	23259	23259	23450	23450	23259	23259	1
35	Dowel Pin	22350	22350	22350	22350	22350	22350	22350	22350	2

¹ Seal (Ref. No. 4) and Seat (Ref. No. 5) must be replaced as a unit and can not be ordered separately.

Seat and Seal Kit 18933 includes Seat 18932 and Seal 10522. Seat and Seal Kit 19279 includes Seat 19277 and Seal 12325.

Parts List

(AMBN1A, AMBV1A, AMBN2A, AMBV2A, AMCN1A, AMCV1A, AMCN2A, AMCV2A)

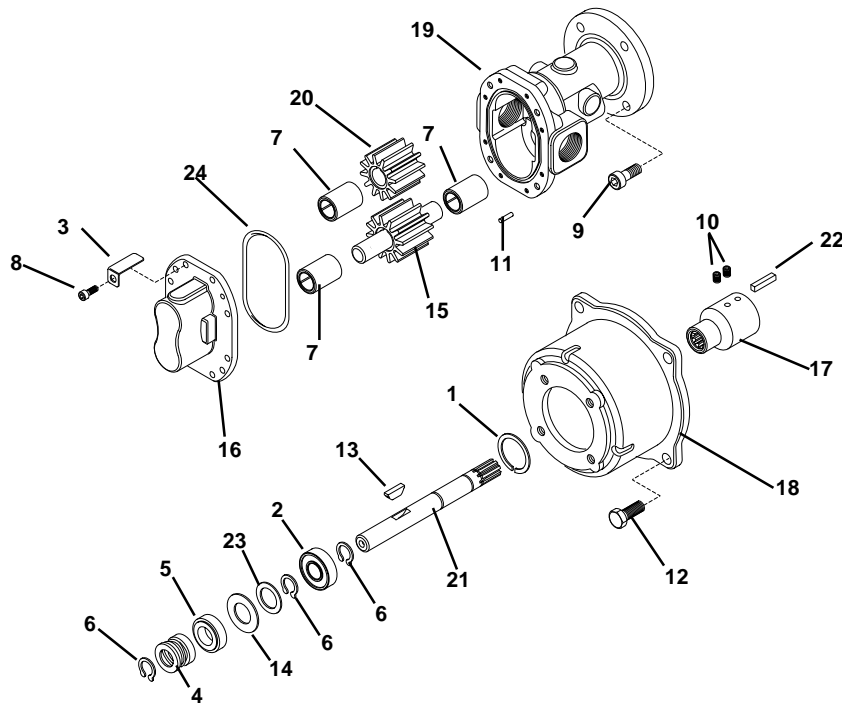

Figure 29

REF. NO.	DESCRIPTION	PART NUMBER BY MODEL								QTY
		AMBN1A	AMBV1A	AMBN2A	AMBV2A	AMCN1A	AMCV1A	AMCN2A	AMCV2A	
1	Retaining Ring	04303	04303	04303	04303	04303	04303	04303	04303	1
2	Ball Bearing	04306	04306	04306	04306	04306	04306	04306	04306	1
3	I.D. Tag	13285	13285	13285	13285	13285	13285	13285	13285	1
4 ¹	Seal	10522	12325	10522	12325	10522	12325	10522	12325	1
5 ¹	Seat	18932	19277	18932	19277	18932	19277	18932	19277	1
6	Retaining Ring	21093	21093	21093	21093	05484	05484	05484	05484	3
7	Carbon Bushing	21332	21332	21332	21332	21332	21332	21332	21332	3
8	10-24 Hex. Hd. Screw	21916	21916	21916	21916	21916	21916	21916	21916	6
9	Screw	21994	21994	21994	21994	21994	21994	21994	21994	4
10	1/4- 20 Set Screw	22161	22161	22161	22161	22161	22161	22161	22161	2
11	Dowel Pin	22350	22350	22350	22350	22350	22350	22350	22350	2
12	Hex. Hd. Screw	22771	22771	22771	22771	22771	22771	22771	22771	4
13	Key	22894	22894	22894	22894	22894	22894	22894	22894	1
14	Washer	22897	22897	22897	22897	22897	22897	22897	22897	1
15	Idler Shaft/Gear Assembly	23778	23778	23881	23881	23882	23882	23883	23883	1
16	Cover	22961	22961	22961	22961	23487	23487	23487	23487	1
17	Spline Coupling Adapter	23102	23102	23102	23102	23102	23102	23102	23102	1
18	Adapter	23260	23260	23260	23260	23260	23260	23260	23260	1
19	Gear Pump Body	23294	23294	23295	23295	23485	23485	23486	23486	1
20	Gear	23412	23412	23407	23407	22893	22893	23511	23511	1
21	Drive Shaft	23450	23450	23259	23259	23450	23450	23259	23259	1
22	Key	21437	21437	21437	21437	21437	21437	21437	21437	1
23	Washer	22896	22896	22896	22896	22896	22896	22896	22896	1
24	O-ring	22626	23684	22626	23684	22626	23684	22626	23684	1

¹ Seal (Ref. No. 4) and Seat (Ref. No. 5) must be replaced as a unit and can not be ordered separately.
 Seat and Seal Kit 18933 includes Seat 18932 and Seal 10522. Seat and Seal Kit 19279 includes Seat 19277 and Seal 12325.

Parts List (AMCN7VA, AMCV7VA, AMCN11VA, AMCV11VA)

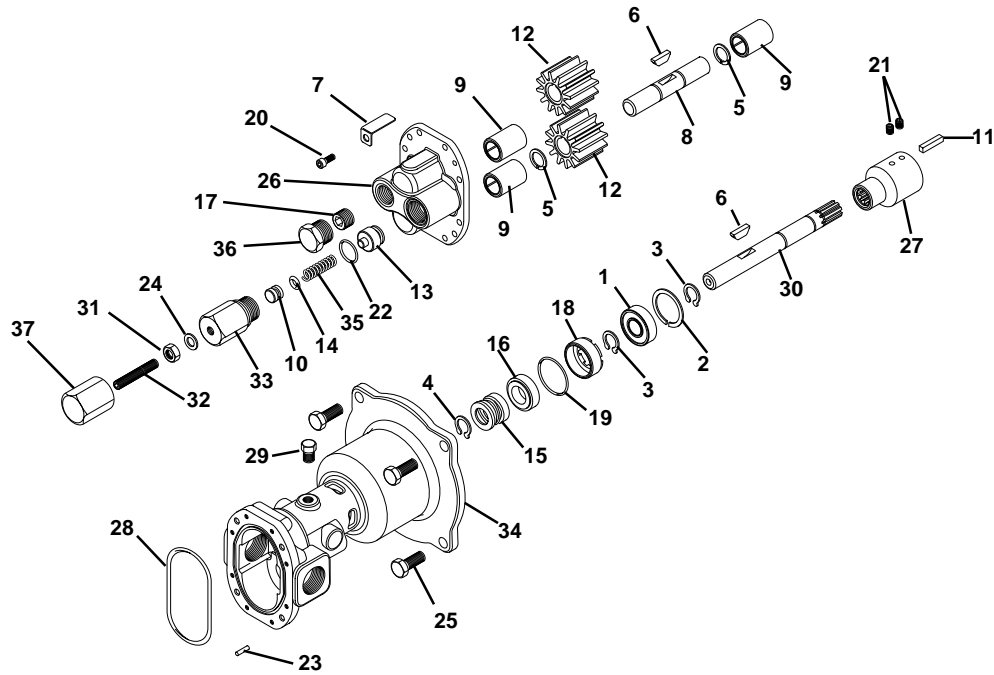

Figure 30

REF. NO.	DESCRIPTION	PART NUMBER BY MODEL				QTY
		AMCN7VA	AMCV7VA	AMCN11VA	AMCV11VA	
1	Bearing	04257	04257	04257	04257	1
2	Retaining Ring	04259	04259	04259	04259	1
3	Retaining Ring	05328	05328	05328	05328	2
4	Retaining Ring	12582	12582	12582	12582	1
5	Retaining ring	12840	12840	12840	12840	2
6	Key	12841	12841	12841	12841	2
7	I.D. Tag	13285	13285	13285	13285	1
8	Idler Shaft	21307	21307	21313	21313	1
9	Carbon Bushing	21333	21333	21333	21333	3
10	Spring Retainer	21422	21422	21422	21422	1
11	Key	21437	21437	21437	21437	1
12	Gear	21457	21457	21458	21458	2
13	Piston (Relief Valve)	21556	21556	21556	21556	1
14	O-ring (Relief Valve)	21568	22527	21568	22527	1
15 ¹	Seal	21644	21439	21644	21439	1
16 ¹	Seat	21645	14527	21645	14527	1
17	Set Screw (Relief Valve)	21709	21709	21709	21709	1
18	Retainer	21864	21864	21864	21864	1
19	O-ring	21913	22174	21913	22174	1
20	10-24 Hex. Hd. Screw	21916	21916	21916	21916	8
21	1/4-20 Set Screw	22161	22161	22161	22161	2
22	O-ring	22234	22526	22234	22526	1
23	Dowel Pin	22350	22350	22350	22350	2
24	Washer	22507	22507	22507	22507	1
25	Hex. Hd. Screw	22771	22771	22771	22771	4
26	Cover	23290	23290	23290	23290	1
27	Coupling Spline	22802	22802	22802	22802	1
28	O-ring	22846	22846	22846	22846	1
29	Pipe Plug	23182	23182	23182	23182	1
30	Drive Shaft	23293	23293	22800	22800	1
31	Jam Nut	23413	23413	23413	23413	1
32	Set Screw	23414	23414	23414	23414	1
33	Relief Valve Cap	23416	23416	23416	23416	1
34	Gear Pump Body	23454	23454	22798	22798	1
35	Spring	04354	04354	04354	04354	1
36	Hex. Head Pipe Plug	21419	21419	21419	21419	1
37	Cap	23415	23415	23415	23415	1

¹ Seal (Ref. No. 15) and Seat (Ref. No. 16) must be replaced as a unit and can not be ordered separately. Seat and Seal Kit 23724 includes Seat 21645 and Seal 21644. Seat and Seal Kit 23725 includes Seat 14527 and Seal 21439.

Parts List (AMCN7A, AMCV7A, AMCN11A, AMCV11A)

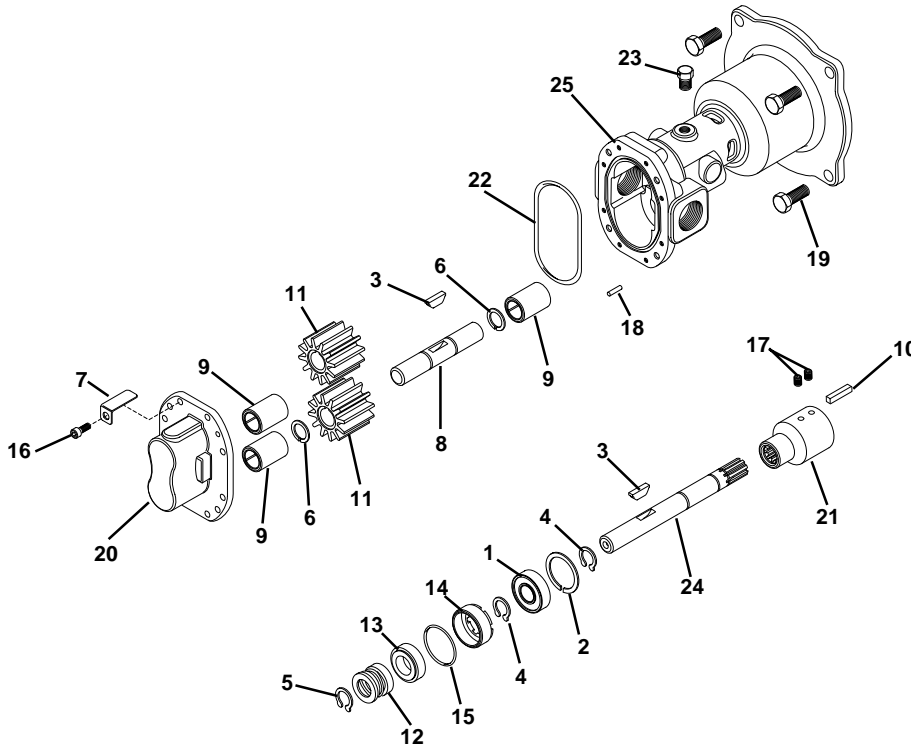

Figure 31

REF. NO.	DESCRIPTION	PART NUMBER BY MODEL				QTY
		AMCN7A	AMCV7A	AMCN11A	AMCV11A	
1	Bearing	04257	04257	04257	04257	1
2	Retaining Ring	04259	04259	04259	04259	1
3	Key	12841	12841	12841	12841	2
4	Retaining Ring	05328	05328	05328	05328	2
5	Retaining Ring	12582	12582	12582	12582	1
6	Retaining Ring	12840	12840	12840	12840	2
7	I.D. Tag	13285	13285	13285	13285	1
8	Idler Shaft	21307	21307	21313	21313	1
9	Carbon Bushing	21333	21333	21333	21333	3
10	Key	21437	21437	21437	21437	1
11	Gear	21457	21457	21458	21458	2
12 ¹	Seal	21644	21439	21644	21439	1
13 ¹	Seat	21645	14527	21645	14527	1
14	Retainer	21864	21864	21864	21864	1
15	O-ring	21913	22174	21913	22174	1
16	10-24 Hex, Hd, Screw	21916	21916	21916	21916	8
17	1/4-20 Set Screw	22161	22161	22161	22161	2
18	Dowel Pin	22350	22350	22350	22350	2
19	Hex. Hd. Screw	22771	22771	22771	22771	4
20	Cover	22799	22799	22799	22799	1
21	Coupling Spline	22802	22802	22802	22802	1
22	O-ring	22846	22846	22846	22846	1
23	Pipe Plug	23182	23182	23182	23182	1
24	Drive Shaft	23293	23293	22800	22800	1
25	Gear Pump Body	23454	23454	22798	22798	1

¹ Seal (Ref. No. 15) and Seat (Ref. No. 16) must be replaced as a unit and can not be ordered separately.

Seat and Seal Kit 23724 includes Seat 21645 and Seal 21644. Seat and Seal Kit 23725 includes Seat 14527 and Seal 21439.

Dimensions

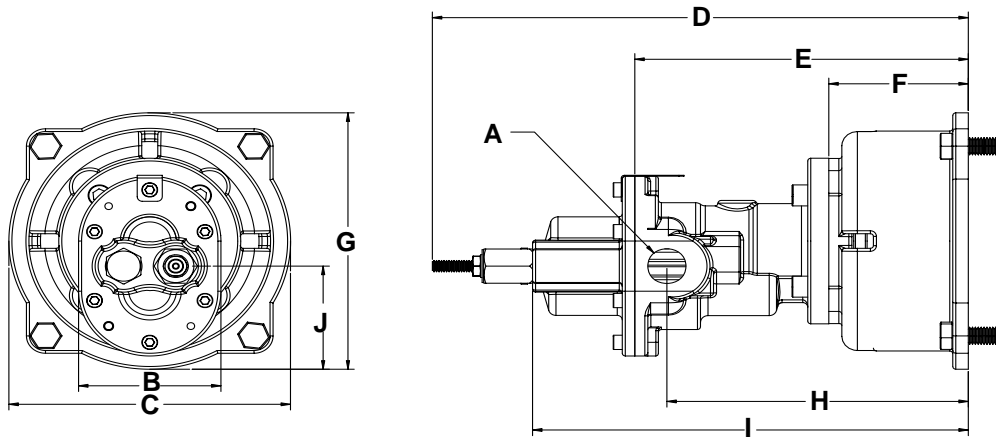

MODEL	A	B	C	D	E	F	G	H	I	J
AMBN1VA AMCN1VA AMBV1VA AMCV1VA	3/8" NPT	2.76" [70.1]	5.62" [142.7]	10.50" [266.7]	6.33" [160.8]	2.78" [70.6]	5.62" [142.7]	5.68" [144.3]	8.38" [212.9]	2.26" [57.4]
AMBN2VA AMCN2VA AMBV2VA AMCV2VA	1/2" NPT	2.76" [70.1]	5.62" [142.7]	11.00" [279.4]	6.83" [173.5]	2.78" [70.6]	5.62" [142.7]	6.19" [157.2]	8.87" [225.3]	2.26" [57.4]

Figure 32

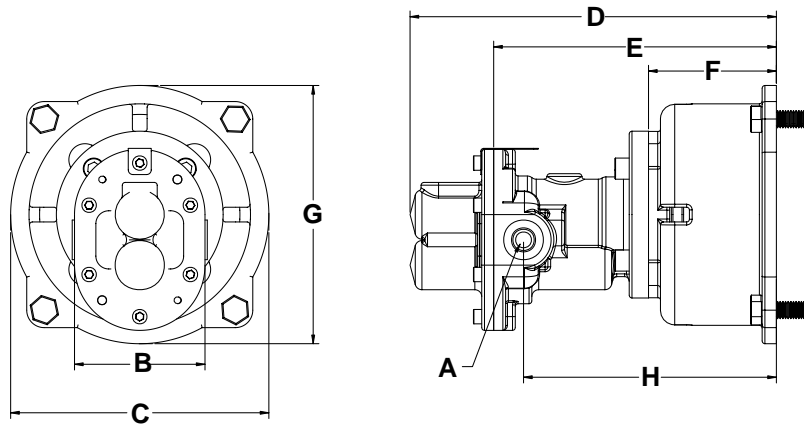

MODEL	A	B	C	D	E	F	G	H
AMBN1A AMCN1A AMBV1A AMCV1A	3/8" NPT	2.76" [70.1]	5.62" [142.7]	8.16" [207.3]	6.33" [160.8]	2.78" [70.6]	5.62" [142.7]	5.68" [144.3]
AMBN2A AMCN2A AMBV2A AMCV2A	1/2" NPT	2.76" [70.1]	5.62" [142.7]	8.48" [215.4]	6.83" [173.5]	2.78" [70.6]	5.62" [142.7]	6.19" [157.2]

Figure 33

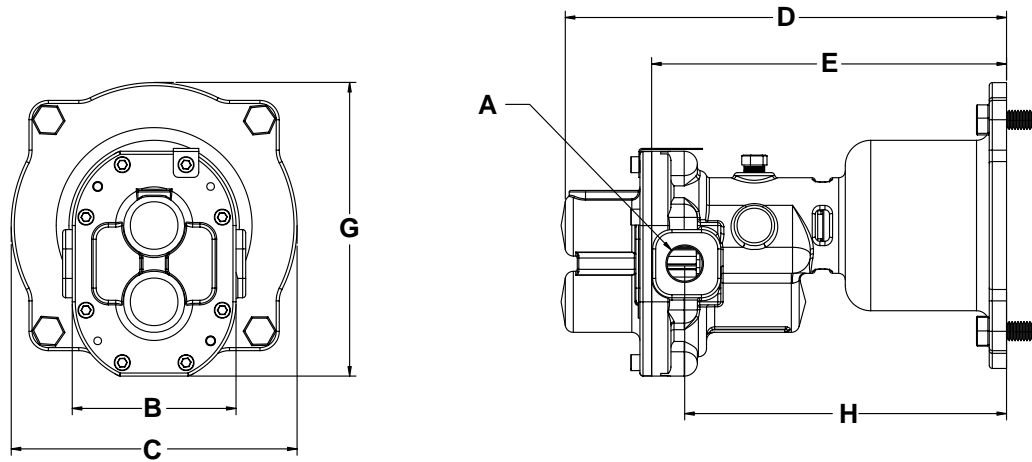

MODEL	A	B	C	D	E	F	G	H
AMCN7A AMCV7A	1/2" NPT	2.22" [56.4]	5.62" [142.7]	8.76" [222.5]	6.98" [177.3]	N/A	5.80" [147.3]	6.33" [160.8]
AMCN11A AMCV11A	3/4" NPT	3.22" [81.8]	5.62" [142.7]	9.13" [231.9]	7.35" [186.7]	N/A	5.77" [146.6]	6.50" [165.1]

Figure 34

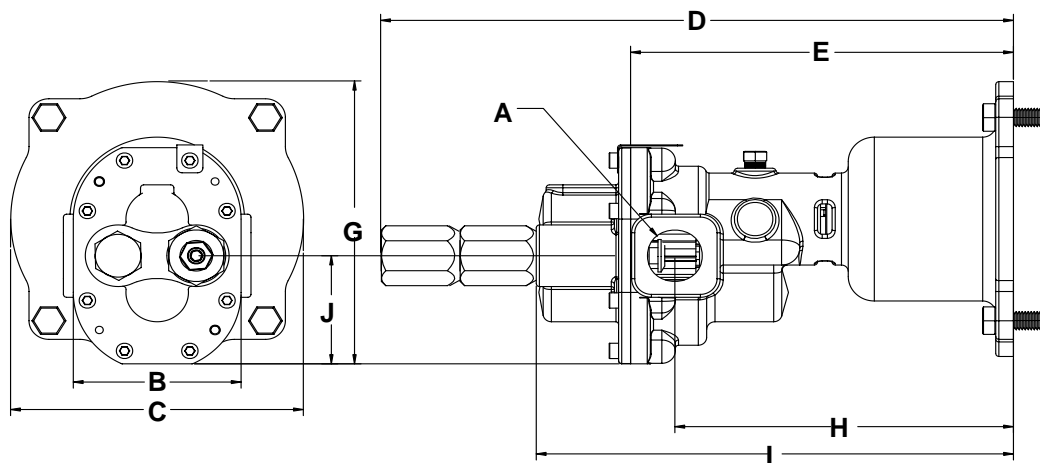

MODEL	A	B	C	D	E	F	G	H	I	J
AMCN7VA AMCV7VA	1/2" NPT	3.22" [81.8]	5.62" [142.7]	11.86" [301.2]	6.98" [177.3]	N/A	5.80" [147.3]	6.33" [160.8]	8.74" [222.0]	2.21" [56.1]
AMCN11VA AMCV11VA	3/4" NPT	3.22" [81.8]	5.62" [142.7]	12.23" [310.6]	7.35" [186.7]	N/A	5.77" [146.6]	6.50" [165.1]	9.11" [231.4]	2.21" [56.1]

Figure 35

Notes

Limited Warranty on Hypro Pumps

Hypro Corporation ("Hypro") warrants to the original purchaser of its products (the "Purchaser") that such products will be free from defects in material and workmanship under normal use for the period of one (1) year for all products except: oil crankcase plunger pumps will be free from defects in material and workmanship under normal use for the period of five (5) years, and accessories will be free from defects in material and workmanship under normal use for the period of ninety (90) days. In addition, Hypro warrants to the purchaser all forged brass pump manifolds will be free from defects in material and workmanship under normal use and from damage resulting from environmental conditions for the life of the pump.

"Normal use" does not include use in excess of recommended maximum speeds, pressures, vacuums and temperatures, or use requiring handling of fluids not compatible with component materials, as noted in Hypro product catalogs, technical literature, and instructions. This warranty does not cover freight damage, freezing damage, normal wear and tear, or damage caused by misapplication, fault, negligence, alterations, or repair that affects the performance or reliability of the product.

THIS WARRANTY IS EXCLUSIVE. HYPRO MAKES NO OTHER WARRANTY, EXPRESS OR IMPLIED, INCLUDING BUT NOT LIMITED TO ANY WARRANTY OF MERCHANTABILITY OR FITNESS FOR A PARTICULAR PURPOSE.

Hypro Corporation's obligation under this warranty is, at Hypro Corporation's option, to either repair or replace the product upon return of the entire product to the Hypro factory in accordance with the return procedures set forth below. **THIS IS THE EXCLUSIVE REMEDY FOR ANY BREACH OF WARRANTY.**

IN NO EVENT SHALL HYPRO BE LIABLE FOR ANY INCIDENTAL OR CONSEQUENTIAL DAMAGES OF ANY KIND, WHETHER FOR BREACH OF ANY WARRANTY, FOR NEGLIGENCE, ON THE BASIS OF STRICT LIABILITY, OR OTHERWISE.

Return Procedures

All pumps or products must be flushed of any chemical (ref. OSHA Section 0910.1200 (d)(e)(f)(g)(h) and hazardous chemicals must be labeled before being shipped* to Hypro for service or warranty consideration. Hypro reserves the right to request a Material Safety Data sheet from the Purchaser for any pump or product Hypro deems necessary. Hypro reserves the right to "disposition as scrap" pumps or products returned which contain unknown substances, or to charge for any and all costs incurred for chemical testing and proper disposal of components containing unknown substances. Hypro requests this in order to protect the environment and personnel from the hazards of handling unknown substances.

For technical or application assistance, call the Hypro Technical/Application number: 800-471-0460. To obtain service or warranty assistance, call the Hypro Service and Warranty number: 800-468-3428; or FAX to: (651) 766-6618.

Be prepared to give Hypro full details of the problem, including the following information:

1. Model number, date of purchase, and place where you purchased your pump.
2. A brief description of the pump problem, including the following:

- Liquid pumped. State the pH and any non-soluble materials, and give the generic or trade name
- Drive type (gas/diesel engine, electric motor, direct/belt drive) and rpm of pump
- Size, type, and mesh of the suction strainer
- Temperature of the liquid and ambient environment
- Suction lift or vacuum (measured at the pump)
- Elevation from the pump to the discharge point
- Discharge pressure
- Size and material of suction and discharge line
- Viscosity (of oil, or other than water weight liquid)

Hypro may request additional information, and may require a sketch to illustrate the problem.

Contact the factory to receive a return material authorization before sending the product. All pumps returned for warranty work should be sent shipping charges prepaid to:

HYPRO CORPORATION
Attention: Service Department
375 Fifth Avenue NW
New Brighton, Minnesota 55112-3288

*Carriers, including U.S.P.S., airlines, UPS, ground freight, etc., require specific identification of any hazardous materials being shipped.

Failure to do so may result in a substantial fine and/or prison term. Check with your shipping company for specific instructions.

SHERTECH®

Printed in the USA
2000 Hypro Corporation

**HYPRO®**

A WICOR COMPANY

INDUSTRIAL PRODUCTS GROUP

375 Fifth Avenue NW • New Brighton, MN 55112-3288 • (651) 766-6300
Phone: 1-800-471-0460 • Fax: 1-800-672-7023