

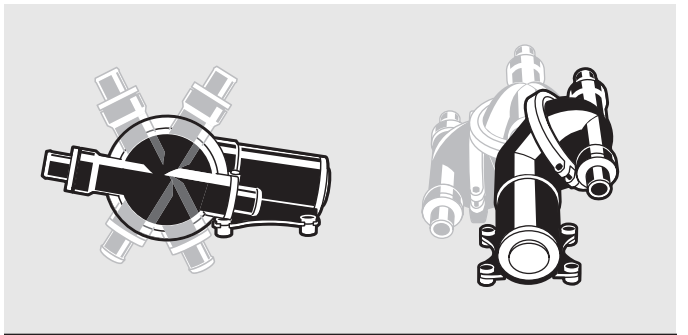

DB412

INSTRUCTION MANUAL

DRY BILGE PUMP WITH PANEL SWITCH



DRY BILGE PUMP WITH PANEL SWITCH

Purpose of This Manual

The purpose of this manual is to provide necessary information for product installation, operation and maintenance.



CAUTION: Read this manual carefully before installing, using or servicing this product. Failure to follow the instructions within this manual could result in explosion, property damage, severe personal injury and/or death.

User Safety

General Safety Rules

- Always keep work area clean
- Pay attention to the risks presented by gas and vapors in the work area
- Avoid all electrical dangers. Pay attention to the risks of electric shock or arc flash hazards
- Always bear in mind the risk of drowning, electrical accidents and burn injuries



DANGER: This product is not intended for damage control or to deal with flooding resulting from hull damage. This product is intended to be used in Bilge Pumping Systems for small craft with a hull length up to 24 meters, as described within the introduction and scope of ISO 15083. Bilge Pumping Systems, as specified in ISO 15083, are limited to normal amounts of water in an intact boat due to spray, rain, seepage, spillage, and occasional small amounts of water shifting from boat movements in heavy weather. Use of product in any other way could result in flooding, catastrophic damage to craft, serious personal injury, or death.



WARNING: This pump is designed for use with fresh water and salt water ONLY. Use with any other hazardous, caustic, or corrosive material could result in damage to the pump and the surrounding environment, possible exposure to hazardous substances and injury.

Bilge pumps shall be mounted in accordance with the pump manufacturer instructions, and in an accessible location to permit servicing and cleaning of the intake and/or screening.

On boats with an enclosed accommodation compartment, an audible alarm shall be installed indicating that the bilge water is approaching the maximum bilge water level. Bulkhead penetrations shall be in accordance with the requirements of ABYC H-2, Ventilation of Boats Using Gasoline, to minimize the potential for migration of carbon monoxide from machinery compartments containing gasoline engines to adjacent accommodation compartments.

Potential electrical sources of ignition located in spaces containing gasoline powered machinery, or gasoline fuel tank(s), or joint fitting(s), or other connection(s) between components of a gasoline system, shall be ignition protected, unless the component is isolated from a gasoline fuel source as described in ABYC E-11.5.3.3

Exception:

1. Boats using diesel fuel as the only fuel source.
2. Outboard engines mounted externally or in compartments open to the atmosphere in accordance with the requirements of ABYC H-2, Ventilation of Boats Using Gasoline.

The bilge pump inlet shall be located so that excess bilge water can be removed from the bilge at static floating position, and at maximum conditions created by the boat's motion, heel, and trim.

Robust Single Diaphragm Design

Features

- Flexible installation
- Compact and simple design
- 12 volt
- Dry running capability
- Connections for 3/4" (19mm) ports and 1.0" (25.4mm) ID hose
- Up to 4.0 US GPM (15 LPM) flow

Specifications

- Suction Lift: 9.5ft (3m)
- 3/4" (19mm) 90° thru-hull fitting included
- Control Panel Switch included
- Relevant Standards:
 - ISO 8846 MARINE Ignition Protection
 - ISO 8849
 - ISO 15083
 - ISO 10133

Performance Rating

Flow @ 12Vdc Nominal Voltage			Hose Size	Max Lift H ₂ O	Max Head H ₂ O
0ft (0m) Head	3ft (1m) Head	6ft (2m) Head			
3.5 GPM (13 LPM)	4.0 GPM (15 LPM)	3.4 GPM (13 LPM)	3/4" (19mm)	9.5ft (3m)	23ft (7m)



WARNING: All marine pumps discharging overboard must be installed with the overboard discharge well above static and heeled waterlines.



WARNING: Do not use any Rule pump for petrol, petroleum products or any products with a flash point below 98°F (37°C), explosion or death may occur.

Installation

- The Rule Bilge Pump is self priming up to 9.5ft (3m).
- Install the Rule Bilge pump in a clean, dry location. (This is not a submersible pump.)
- Uses multi-positional ports for easy mounting of the pump.
- If mounted vertically, the motor should be above the pump head.
- Use rubber grommets provided to absorb vibration.
- Use 3/4" (19mm) i.d. spiral reinforced hose (with a smooth internal bore), or semi-rigid pipework systems.
- Connect the hose to inlet and outlet of pump using stainless steel hose clamps.
- All suction connections must be airtight and free of sharp bends or restrictions.
- Inlet hose should run to the deepest point of the bilge area.
- Inlet hose should be cut at an angle in the bilge and be secured on a bulkhead or stringer with stainless steel clamps to pick up all of the bilge water.
- Run the discharge hose from the pump to the 90° thru-hull.
- Install the thru-hull with a water tight sealant and above the water line of the vessel.
- Use a 7/8" (22mm) hole saw to cut the hole for the 90° thru-hull.
- Secure all plumbing hoses to a bulkhead or stringer.

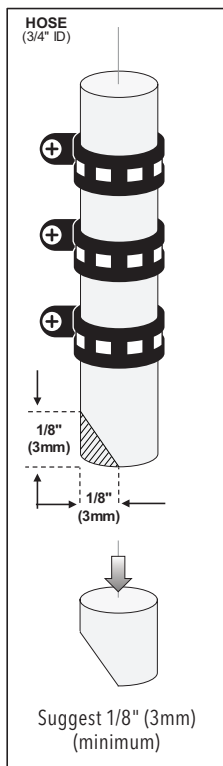

Electrical

Disconnect power before installing or servicing the pump.

All potential sources of ignition located in spaces containing gasoline powered machinery or gasoline fuel tank(s), or joint fitting(s), or other connection(s), between components of a gasoline system, shall be ignition protected in accordance with the requirements of ISO 10133, ABYC E-11, AC and DC Electrical Systems On Boats.

The electrical wiring, connections, and installation shall be in accordance with the requirements of ISO 10133, ABYC E-11, AC and DC Electrical Systems On Boats.



CAUTION: Disconnect power from the system before working on the unit to avoid personal injury, damage to the surrounding environment and/or damage to the unit.



CAUTION: Always install proper fuse size to prevent damage to product should a short occur. Failure to install proper fuse could increase risk of pump malfunction potentially resulting in personal injury and/or fire hazard.



CAUTION: Keep all wire connections above the highest water level. Wires must be joined with butt connectors and a marine grade sealant to prevent wire corrosion.

Wiring Instructions

- Make all electrical connections in dry locations; connections in humid environments should be sealed to prevent corrosion.
- Protect the circuit with a rated fuse or circuit breaker in the red positive (+) lead as close as possible to the power source.
- Connect the black motor wire to the negative (-) battery terminal.
- Inadequate voltage at the motor terminals when the pump is running (not less than 10% below rated voltage at full load) due to partially discharged batteries or insufficient cable size may result in blowing fuses, failure to start or poor pump performance.
- Ensure sterilization of wet end before disassembly.

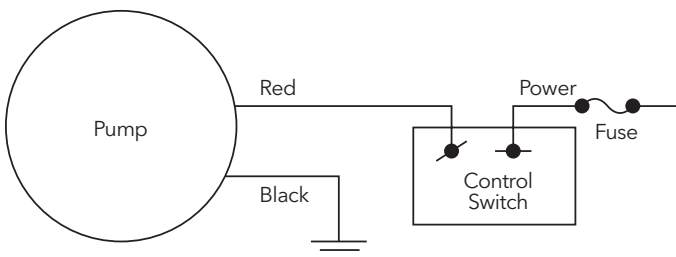

Model No.	Voltage	Max Current	Max Fuse Size	Wiring Size*		
				AWG	mm ²	Max Length
50880-1000	12V	8A	10A	14	2.5	30ft (9m)

*for longer installations, fit thicker cables



WARNING: If the fuse fails repeatedly do not fit a heavier fuse or bridge the fuse terminals with silver paper or metal wire. Failure to observe this instruction may result in a fire hazard due to overheating of cables.

Plumbing

Factors that reduce the flow of a bilge pump may include but are not limited to the following:

- The length of discharge piping (longer runs reduce flow)
- The number or radius of bends
- Excess amount of debris in water. A strainer or other means of preventing debris from entering the pump inlet should be used to prolong life and performance.
- The roughness of the interior surfaces of piping and fittings (smooth bore hose is best)
- The reduction (hose restriction) in cross-sectional area of discharge system components such as check valves and thru-hulls

The discharge may be located below the maximum heeled waterline if the discharge line is provided with both of the following:

- A seacock installed in accordance with the requirements of ABYC H-27, Seacocks, Thru-Hull Connections, and Drain Plugs, and
- A vented loop to prevent siphoning into the boat. A check valve shall not be used for this purpose.

If the discharges of several pumps are manifolded to discharge through a single thru-hull fitting, the system shall be designed so that the operation of one pump will not back feed another pump, and the simultaneous operation of each pump will not diminish the pumping capacity of the system. A check valve shall not be used in the discharge manifold system.

During the winterization of a vessel, it's recommended that you remove the check valve and drain any residual water from the plumbing.

Periodically remove, clean and inspect bilge pump, check valve and its surroundings for damage or debris that may reduce the performance of the pump.



All mounting holes must be sealed with a marine grade sealant to prevent water intrusion.

ABYC
Setting Standards for Safer Boating®

Install to ABYC H-22 and E-11

Operation

The dc motor is suitable for intermittent duty and should not be run for more than 30 minutes continuously.

Rotation of Pump Head

1. Push down on clip and remove end cover
2. Internal bolt heads now exposed
3. Undo all four mounting bolts
4. Remove bolts and grasp motor unit firmly
5. Rotate pump head to desired position
6. Example of pumps rotational capabilities
7. Replace all 4 internal bolts and secure tightly
8. Replace end cover

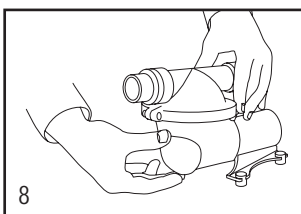
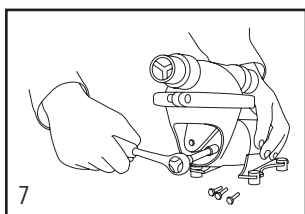
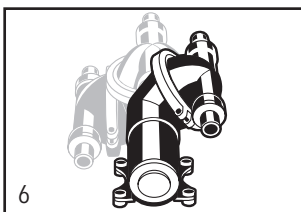
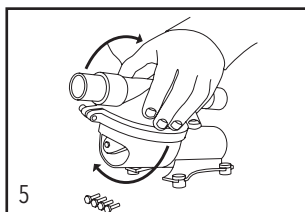
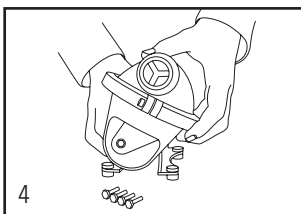
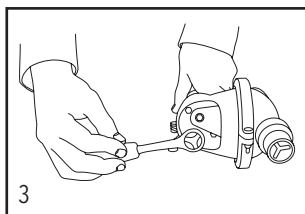
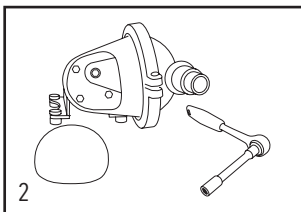
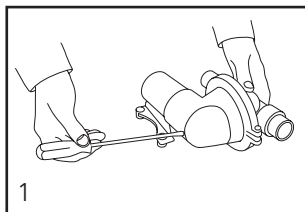

Rotation of Ports

1. Undo clamp using allen key
2. Remove clamp
3. Rotate port unit to desired location
4. Example of pumps rotational capabilities
5. Replace clamp and tighten until firmly secure

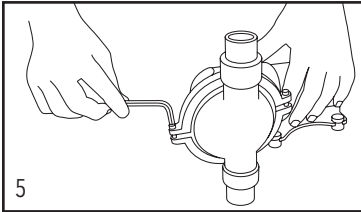
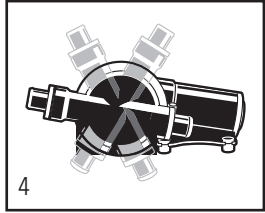
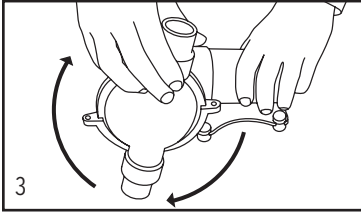
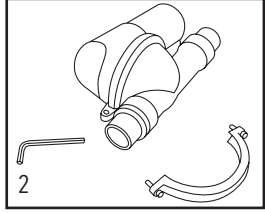
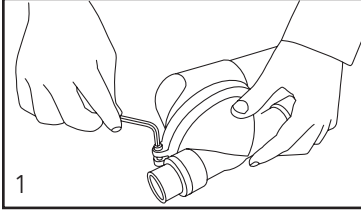

Maintenance



WARNING: Always disconnect pump from power supply.

Check all electrical connections periodically, particularly in salt water areas. Corrosion can cause loss of performance or non-operation in extreme cases. The motor should be protected with a corrosion inhibiting spray and any rust should be removed and the motor repainted.

Exploded View

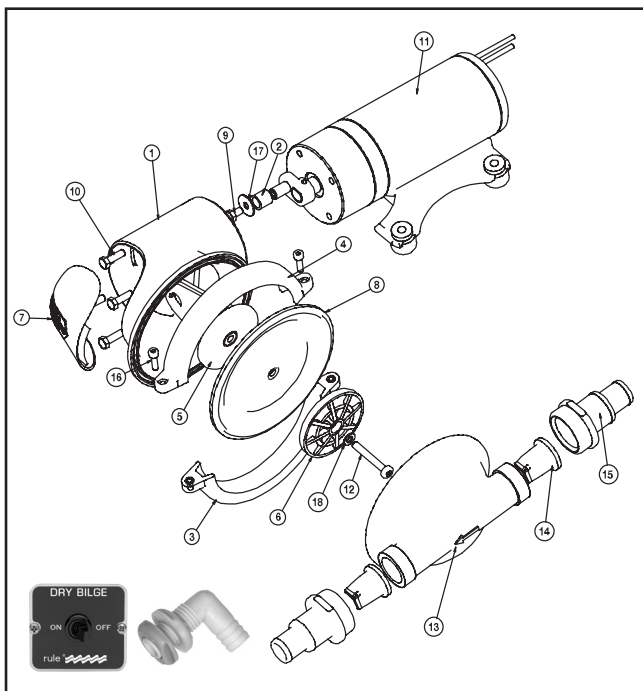

Part Numbers			
Model	Description	Voltage	Fuse Sizes
DB412	Complete Kit	12V	10A
50	Panel Switch	12V	

Service Kits	
Model	Description
SK880	Service Kit - Bilge Pump
50886-1000	Clamp Kit
61	Thru Hull Fitting - 3/4" Right Angle

Key	Description	Quantity in Kit
1	Bracket	
2	Bush	
5	Con Rod	
6	Con Rod Plate	
9	Hex Head Screw	
11	Motor Assembly	
13	Shower Drain & Bilge Pump Chamber	
17	Washer	
Bilge Pump Service Kit		
7	Cover	1
8	Diaphragm	1
10	Hex Head Screw	4
12	Screw Recessed Pan Head	1
14	Shower Drain & Bilge Pump Joker Valve	2
15	Shower Drain & Bilge Pump Port	2
18	Washer	1
Clamp Kit		
3	Clamp Bottom	1
4	Clamp Top	1
16	Socket Head Screw	2

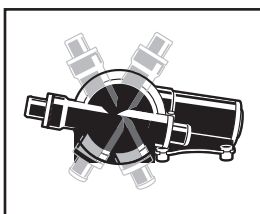
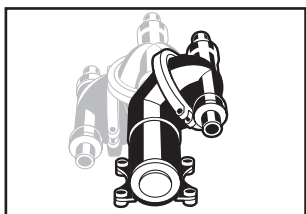

Dimensional Drawing

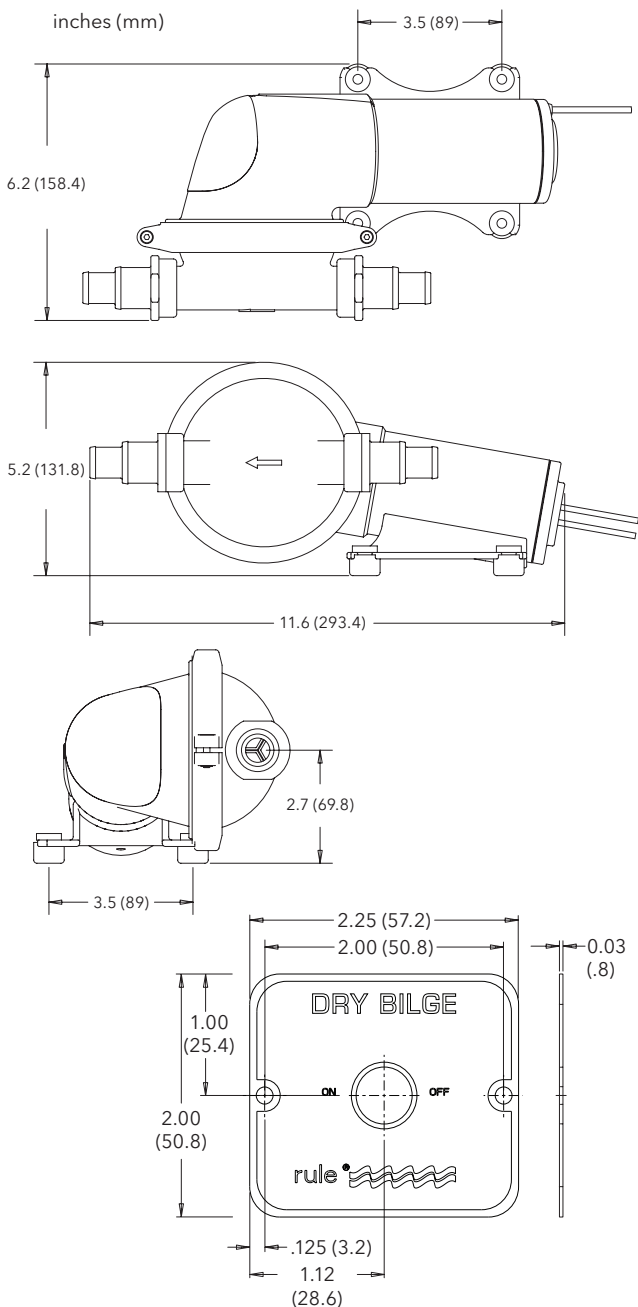

xylem
Let's Solve Water

USA

100 Cummings Center,
Ste. 535-N
Beverly, MA 01915
Tel: +1-978-281-0440
Fax: +1-978-283-2619

UK

Bingley Road, Hoddesdon
Hertfordshire EN11 0BU
Tel: +44 (0) 1992 450145
Fax: +44 (0) 1992 467132

GERMANY

Oststraße 28
22844 Norderstedt
Tel: +49 (0) 40 53 53 73 0
Fax: +49 (0) 40 53 53 73 11

ITALY

Via Tommaseo, 6, 20059
Vimercate, Milano
Tel: +39 039 685 2323
Fax: +39 039 666 307

Discover Rule at www.xylem.com/rule

Warranty: All products of the company are sold and all services of the company are offered subject to the company's warranty and terms and conditions of sale, copies of which will be furnished upon request

© 2020 Xylem. All rights reserved. Rule is a trademark of Xylem or one of its subsidiaries.

950-0548 Rev. B 05/2020