

**INSTALLATION, OPERATION  
AND  
MAINTENANCE MANUAL  
FOR ROPER  
“ROC” TYPE 1  
STAINLESS STEEL PUMPS  
SIZES X5, 01, 02, AND 03**



Roper Pump Company  
P.O. Box 269  
Commerce, Georgia 30529 USA

Telephone: (706) 335-5551  
TeleFAX: (706) 335-5505

# CONTENTS

## Section 1.0:

- Section 1.0 Table Of Contents
- Nameplate Data
- Maximum Pump Ratings

## Section 2.0:

- Section 2.0 Table of Contents
- Introduction
- Safety Precautions
- Preoperation Checks
- Preparation of Foundation
- Aligning Driver and Pump
- Additional Important Warnings and Information
- Installation of Pipes
- Threaded Port Connections
- Checking Pump Performance
- Replacement Parts
- Index

## Section 3.0:

- Section 3.0 Table of Contents
- Safety Signal Words and Symbols
- Recommended Tool List
- Direction of Rotation for Standard Drive Pumps
- Direction of Rotation for Mag Drive Pumps
- Instructions for Draining Pump
- Instructions for Standard Drive Pump Disassembly
- Instructions for Mag Drive Pump Disassembly
- Dimensional Data for Internal Parts
- Instructions for Standard Drive Pump Assembly
- Instructions for Mag Drive Pump Assembly
- Pump Sectional Drawings
- Parts List
- Shaft Sealing
- Common Maintenance Questions
- Index

# Section 1.0

## TABLE OF CONTENTS

<b>Section</b>		<b>Page</b>
1.1	<b>Nameplate Data .....</b>	<b>1 - 1</b>
1.2	<b>Maximum Pump Ratings.....</b>	<b>1 - 3</b>

Roper is a registered trademark of Roper Pump Company, a Delaware Corporation

Viton® and Kalrez® is a registered trademark of E. I. duPont de Nemours Co. (Inc.)

# 1.1 NAMEPLATE DATA

Roper identifies each pump manufactured by a metal nameplate attached to the pump. This nameplate describes the pump as built at the factory. Copy the nameplate data from your pump in the area provided below. Use this for ready reference when ordering repair parts or when consulting with a Roper distributor or Roper Pump Company about this pump.

FIGURE NUMBER: \_\_\_\_\_

SPEC NUMBER: \_\_\_\_\_

TYPE: \_\_\_\_\_

SERIAL NUMBER: \_\_\_\_\_

## PUMP NOMENCLATURE

Example: 01SS1PTYDJOHX SPEC XXX  
TYPE 1 SERIAL NO. ZZZ

1. The FIGURE number consists of an eleven to thirteen digit number.

- The first two digits (01) indicates the approximate theoretical displacement in US gallons per 1000 revolutions.

Gallons/1000 Rev. [Liters/1000 Rev.]

.5 [1.89]

1 [3.78]

2 [7.57]

3 [11.36]

- The third digit (S) indicates the housing material.  
S - 316 Stainless Steel  
C - Steel
- The fourth digit (S) indicates the gear material.  
S - 17-4 PH vs. 17-4 PH Stainless Steel
- The fifth digit (1) indicates the drive configuration.
- 1 - Standard Coupled without outboard bearing.

2 - Standard Coupled with outboard bearing.

3 - Mag drive, 5 lb/ft torque, Neodymium.

7 - Special, (covered by a Spec. No.)

- The sixth digit (P) indicates whether or not the pump is equipped with an internal relief valve.

P - Plain

- The seventh digit (T) indicates the type of shaft seal.

T - Single Mechanical Seal

U - Packing

W - Sealless (mag drive)

X - Special (covered by the Spec. No.)

- The eighth digit (Y) indicates the elastomer material used.

Y - PTFE Encapsulated

Z - Solid PTFE

K - Kalrez®

V - Viton®

N - Buna

E - EPDM

X - Special covered by Spec Number

- The ninth digit (D) indicates the bearing material used.

D - Carbon

Q - Special (covered by the Spec. No.)

- The tenth digit (J) indicates the type of pump mounting.

G - Pump with feet. (Use only with "H" or "M" in the eleventh position.)

J - Footless mag drive or standard drive pump and/or bracket (Mag or Standard Drive),

I - Mag drive pump with feet on bracket.

- The eleventh digit (0) indicates the final unit shipped.

H - Bare pump without accessories (includes the bracket and coupling on mag drive pumps).

M - Mounted pump and accessories.  
(Includes base or bracket mounted  
standard drive pumps with or  
without the motor.)

O - Pump less bracket and coupling for  
footless pumps and mag drives. Q  
is not to be used for standard drive  
pumps with feet; use H for these.

- The twelfth digit (L) indicates the drive  
shaft position.

L - Low drive; Standard

H - High Drive

- The thirteenth digit (C) indicates the drive  
shaft rotation.

W - Clockwise rotation; Standard

X - Counterclockwise Rotation

Example:

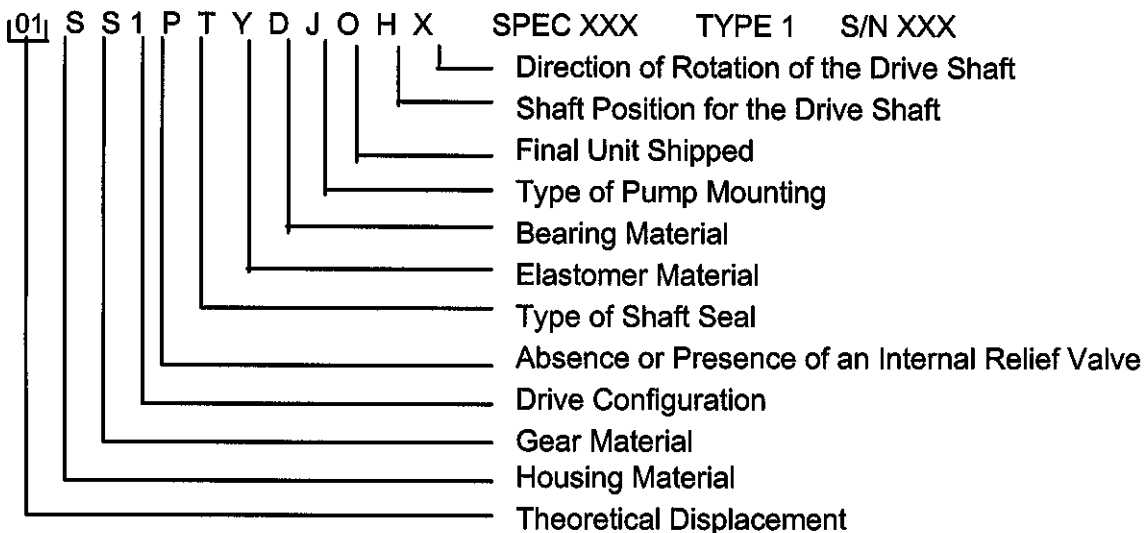

**NOTE:** The preceding description of the figure number is to assist in identifying your Roper pump. **DO NOT** attempt to derive any ratings or performance from the figure number. For assistance in pump selection, it is recommended that you consult a Roper distributor or Roper Pump Company.

2. Occasionally, special pumps or configurations are required which are unique for a particular application. These modifications are clarified by a SPECification number. Identification of any items different than a standard pump can be made by consulting a Roper distributor or Roper Pump Company.
3. The TYPE number is a number used by Roper for in-house identification of construction and hydraulics. Always include the type number in any references to the pump.
4. The SERIAL number is a unique number assigned to each pump built by Roper Pump Company.

In any communication concerning this pump, always be sure to include the Figure, Spec, Type, and Serial numbers so proper identification of the pump can be assured.

## 1.2 MAXIMUM PUMP RATINGS

The maximum pressure and speed limits for this pump SERIES are shown below.

The maximum rating of a pump with a SPEC number may be lower depending on the materials of construction.

Maximum limits for this SERIES:

300 psi [20.7 Bar] Maximum Inlet Pressure

300 psi [20.7 Bar] Maximum Discharge Pressure

299 psi [20.6 Bar] Maximum Differential Pressure

3600 rpm Maximum Speed

Maximum Temperature Limits for standard pumps (no spec number) are:

Mechanical Seal Pumps: 350°F [180°C]

Packed Box Pumps: 350°F [180°C]

TABLE OF CONTENTS

<b>Section</b>		<b>Page</b>
2.1	Introduction -----	2 - 1
2.2	Safety Precautions -----	2 - 2
2.3	Preoperation Checks -----	2 - 3
2.4	Preparation of Foundation -----	2 - 4
2.5	Aligning Driver and Pump -----	2 - 5
2.6	Additional Important Warnings and Information -----	2 - 9
2.7	Installation of Pipes -----	2 - 10
2.8	Threaded Port Connections -----	2 - 11
2.9	Checking Pump Performance -----	2 - 12
2.10	Replacement Parts -----	2 - 13
2.11	Index .....	2 - 14

## 2.1 INTRODUCTION

### ! IMPORTANT

**THIS MANUAL MUST ACCOMPANY THE PUMP UPON ALL TRANSFERALS. MAKE SURE THE OPERATOR OF THE EQUIPMENT HAS READ AND UNDERSTANDS THIS MANUAL BEFORE OPERATING THE PUMP OR ANY RELATED EQUIPMENT.**

When properly selected, installed, operated, and maintained, Roper pumps will provide long, dependable service. Remember, faulty selection and installation form the basis of more pump troubles than all other causes combined. No amount of maintenance can compensate for selection and installation mistakes. Read this manual carefully and understand it totally before installing or operating the pump which it accompanies.

This pump is satisfactory for its rated conditions. Its operation beyond these conditions may subject it to stresses and strains that it is not designed to withstand.

Install ample coupling or belt guards for the protection of personnel.

This manual will cover standard pumps and most SPECification number pumps. Appearance may vary among pumps and construction may vary on spec. number pumps. Specification numbers are assigned to pumps with other than standard features. Roper produces specific manuals for most standard line pump models. Contact Roper to find out if the pump model you have has a specific manual and to request a copy.

If there is any question concerning the ratings, instructions, or compatibility of the pump with the pumped liquid, consult a Roper distributor or:

**Roper Pump Company**  
P.O. Box 269  
Commerce, Georgia 30529 USA  
Telephone: (706) 335-5551  
TeleFAX: (706) 335-5505

### ! IMPORTANT

Read the following before starting the pump! Failure to heed these warnings may result in an accident causing physical damage, serious personal injury, or death!

- Read and understand all tags and installation and operating instructions.
- **WARNING!** Install proper guard(s). **DO NOT** operate pump without guard(s) in place. Even with proper guard(s) installed, always use caution near rotating parts including the drive system for the pump. Serious injuries and death have occurred from becoming entangled in rotating shafts.
- **WARNING! DO NOT** operate this equipment in excess of its rated capacity, pressure, speed, and temperature, or other than according to the instructions contained in this manual.
- **WARNING!** Install and properly set devices into the system to prevent the chance of too much pressure, high temperature, and driver overload. The pump is not provided with these devices.
- **WARNING!** Proper measures and safeguards must be taken to avoid spillage and overflow from overfilling or putting too much pressure on any component of the system. This includes the receiver and lines.
- Know the operating conditions.
- Open all lines before starting pump.
- *This manual contains general information concerning the use, inspection, adjustment, and test of the pump furnished. For certain applications and installations, other precautions and safety measures may be appropriate and are the responsibility of the product installer and user. Users of this pump must have ample knowledge and training to apply sound safety and operating practices that may not be mentioned in the manual, and Roper's sale of this pump is in reliance on such user knowledge and training.*



## **2.2 SAFETY PRECAUTIONS**

---

**WHEN LIQUID BEING PUMPED IS HAZARDOUS OR VOLATILE, ALWAYS TAKE FULL PRECAUTIONS. THIS INCLUDES THE RUN-IN PERIOD AND DURING DISASSEMBLY AND ASSEMBLY OF PUMP.**

*Controls, guards, walkways, machine arrangement, crew training, etc., are all necessary factors in the creation of a safe, practical installation and are generally not a part of our services. It is the responsibility of the contractor, installer, owner, and user to add to the materials furnished by Roper to result in a safe installation and to comply with OSHA, state and local laws, and the ANSI/NFPA Life Safety Code.*

There are many kinds of devices for pumps and systems such that if one component in a system is stopped, other equipment feeding or following it also can be automatically stopped. Serious thought should be given to the installation of these types of devices in every pump system.

- **DO NOT** attempt to install, operate, or perform maintenance on this equipment without first reading and understanding the material in this manual. Also, read and understand all tags and any other documentation accompanying the pump.
- **DO NOT** operate this equipment in excess of its rated capacity, pressure, speed, and temperature, or other than according to the instructions contained in this manual.
- **DO NOT** continue to operate this equipment if there is a failure of any part of the equipment or system. Correct the failure before operating the equipment.
- **DO NOT** bypass safety controls or guards. Their purpose is to protect and they must be in proper working order.
- **DO NOT** operate equipment without proper guards in place.
- **DO NOT** walk, stand, sit, or lean on guards.
- **DO NOT** work on a pump while it is operating or if there is a chance of the driver becoming energized except to adjust the relief valve.
- **DO NOT** adjust packing while the pump is operating or if there is a chance of the driver becoming energized.
- **DO NOT** adjust the integral relief valve without coupling guards in place.
- **DO NOT** place hands, feet, head, or any other part of your body in any pump opening while the pump can be operated.
- **DO NOT** poke or prod material in the pump.
- **DO NOT** start to disassemble the pump if there is the slightest chance of it becoming energized by accident. Lock out the energy source to the driver and disconnect the coupling before performing maintenance to the equipment.
- **DO NOT** wear loose or dangling clothing or jewelry near the equipment. It could become caught and possibly cause serious injury or death.
- **DO NOT** use metallic or hard faced striking tools when the need for tapping parts into position arises. Hard faced striking tools may damage parts or they may fracture or chip and send particles flying that could cause possible injury.
- **DO NOT** allow spills to remain in the work area. Clean up spills immediately. Oils, greases, and other fluids used in the equipment may create hazards if not cleaned up immediately after a spill.
- **DO NOT** spin bearings with compressed air. This is highly dangerous and can cause the bearing to fragment with explosive force, possibly causing serious injury or death.
- **DO NOT** attempt to install, use, or repair this equipment while under the influence of any substance that may impair physical or mental abilities. This includes, but is not limited to, alcohol and prescription and nonprescription drugs.

- **DO NOT** dispose of fluoroelastomers by burning. Toxic vapors are released by this compound upon combustion.
- **DO NOT** suspend pumps from the ports unless they have been specifically designed for this type of mounting.

- 
- **DO** completely read and understand the information contained in this manual. *The operator of the equipment must be familiar with these instructions.*
  - **DO** stop the pump in a manner that there is no chance of the driver becoming energized while any kind of work is being performed on the pump or system.
  - **DO** always keep safety in mind.
  - **DO** know the operating conditions of the equipment.
  - **DO** take proper measures and precautions to avoid spillage and overflow from overfilling or putting too much pressure on any component of the system.
  - **DO** identify all possible hazards and decide what controls are needed. Remember, only you understand your product and system characteristics fully. *The ultimate responsibility for the application and safety is with you.*
  - **DO** install and properly set devices into the system to prevent the chance of dry operation, overpressure, excessive temperature, and driver overload.
  - **DO** provide guards for all exposed rotating parts, including all parts of the drive system, to prevent possible injury.
  - **DO** be careful when working near an operating pump. Contacting or getting caught in rotating parts may cause serious or fatal injury.
  - **DO** keep equipment in good working order, especially safety devices and guards.
  - **DO** be aware of your location relative to the equipment.
  - **DO** wear proper clothing near the equipment. Safety glasses or goggles,

and safety shoes are recommended. They will help reduce the chance of injury.

- **DO** use soft faced striking tools when the need for tapping parts into position arises. Rubber or plastic faced striking tools are recommended.
- **DO** practice good housekeeping. Clean up spills immediately. Keep the work area clean to avoid hazards. Always be sure of your footing around the equipment to avoid a possible fall and injury.
- **DO** use proper tools. Avoid *cheater* bars as they are a source for serious injury should they slip or break.
- **DO** mount pumps in the manner they were designed to be mounted.

## **2.3 PREOPERATION CHECKS**

*Read and understand the instructions and recommendations contained in this manual.*

Disconnect the coupling between the driver and pump.

Test the rotation of the driver to make sure it will operate the pump in the desired direction of rotation. Rotation is shown on the pump in relation to the integral relief valve. When an integral relief valve is used, make sure it is positioned and adjusted as discussed in the section titled, **DIRECTION OF ROTATION AND RELIEF VALVES**. After the unit is mounted and the piping is connected, the pump should be checked to be sure it operates freely without binding. After operation is proved satisfactory, both pump and driver should be tightly secured and the alignment rechecked before operation.

Before starting, make sure all guards are in place and the inlet and discharge valves are opened. After starting the unit, check to see that the pump is delivering liquid. If not, stop the driver immediately and refer to Section 2.9, **CHECKING PUMP PERFORMANCE**. After the pump is delivering liquid, check the unit for excessive vibration, localized heating, and excessive shaft seal leakage. Check the pressure or vacuum by installing gauges at

both the inlet and discharge sides of the pump to make sure the pressure or vacuum conform to specifications.

## **WARNING**

If there is no pressure relief device in the system, **NEVER** block the discharge line. If there is a relief valve in the system, **NEVER** block the discharge line between the relief valve and pump. High pressure will occur, resulting in possible damage or breakage to the pump or system parts and possible injury to personnel. **DO NOT** operate the pump for more than one minute with the discharge line blocked downstream of the relief valve. Rapid heating and possible damage will occur. Even an open discharge line does not prevent the possibility of high pressure. Discharge line length, diameter, and arrangement along with fluid viscosity and velocity also can create a high pressure situation at the pump.

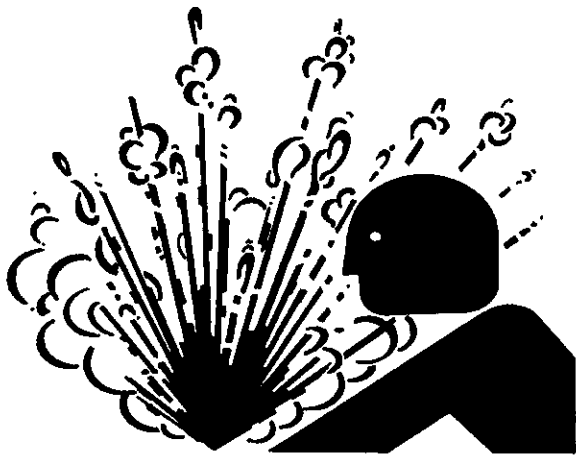

**WARNING! DO NOT** overpressurize pump or system.

## **2.4 PREPARATION OF FOUNDATION**

Locate the pump so that it is as low and as close to the fluid source as practical and so that piping to and from the pump will be as short and simple as practical. The pump and its driver must be accessible for inspection

and maintenance. Accessibility to the unit and adequate clearance should be a major thought in any installation. The driver must be suitable for the environment (for example; open, splash proof, totally enclosed, or explosion proof electric motor). If the driver is not suitable, choose a different location or obtain another driver.

For best pump-driver unit life, mount each unit on a strong, fabricated, structural steel baseplate with a proper foundation. A good foundation is of major importance to the total installation. A thick, heavy concrete foundation is best since it is heavy enough to support the baseplate rigidly and absorb strain and shock. Locate anchor bolts for the baseplate in the foundation. Use a pipe sleeve, two to three times as large as the anchor bolts, around the anchor bolts to allow some lateral bolt movement during final positioning of the unit.

Place the unit, with the pump and driver mounted on the baseplate, on the foundation and disconnect the coupling (flexible coupling, belts and sheaves, etc.). **DO NOT** reconnect the coupling until all alignment operations are complete. Support the baseplate on rectangular metal blocks and shims or on metal wedges having a small taper. Place the support pieces close to the anchor bolts and directly under the part of the baseplate carrying the greatest weight. Space the support pieces close enough to give uniform support. Allow a gap of about 3/4 inch [19 mm] to 1-1/2 inches [38 mm] between the foundation and baseplate for grouting. Refer to Fig. 2.4.1.

Adjust the metal supports or wedges until the shafts of the pump and driver are level. At this time, check the faces of the inlet and discharge connections of the pump for horizontal or vertical position using a level. Correct the positions, if necessary, by adjusting the supports or wedges under the baseplate as required.

For maximum rigidity and lower noise levels, grout the baseplate to the foundation. Use a good grade of nonshrink grout. When all alignments are correct (refer to Section 2.5, **ALIGNING DRIVER AND PUMP**), tighten the anchor bolts evenly but not too firmly. Then

grout the unit to the foundation. Completely fill the baseplate with grout. It is desirable to grout the leveling pieces, shims, or wedges in place. Fill the spaces between the anchor bolts and sleeves with grout, also. Allow the grout to dry according to the manufacturer's instructions. **DO NOT** fully tighten the anchor bolts until the grout has hardened.

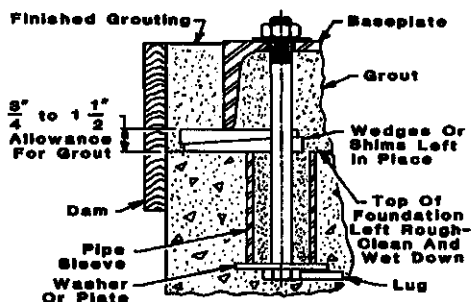

Fig. 2.4.1: Typical Baseplate Anchoring

After the grout has hardened and the anchor bolts have been properly tightened, check the unit for parallel and angular misalignment, and if necessary, take corrective measures. After the piping to the unit has been connected, check the alignment again.

**NOTE:** Attempts to correct alignment in one direction may alter the alignment in the other direction. Therefore, it is necessary to check alignment in all directions after making any adjustments.

Schedule semiannual inspections and checks of the foundation anchor bolts as part of a preventive maintenance program. If loose foundation bolts are found, tighten them and check the unit alignment.

Normal mounting for this pump is horizontal with the pump above the baseplate, properly grouted to a concrete foundation placed in or on solid earth. Mountings other than described above (such as vertical mounting, wall mounting, ceiling mounting, etc.) may require special components and precautions. Extra pump supports, special drivers, and extra anchor bolts may be necessary in unusual mountings. If your application requires other than normal mounting, as described above, you are urged to consult Roper Pump Company for assistance in

determining any special needs that may be required.

## 2.5 ALIGNING DRIVER AND PUMP

The flexible coupling or belts and sheaves must be accurately realigned during and after installation. Refer to the flexible coupling or belt and sheave manufacturer's recommendations and instructions for the requirements for proper alignment. Also refer to Section 2.4, **PREPARATION OF FOUNDATION**, for additional information.

### FLEXIBLE COUPLING

**DO NOT** use a flexible coupling to compensate for misalignment of the driver and pump shafts. The purpose of the flexible coupling is to compensate for temperature changes and to permit end movement of the shafts without interference with each other while transmitting power from the driver to the pump.

The faces of the coupling halves should be spaced far enough apart so that they cannot strike each other when the driver rotor is moved hard over toward the pump. The necessary tools for *approximate* checking of the alignment of a flexible coupling are a straight edge and a taper gauge or a set of feeler gauges.

# DANGER

Make sure there is no chance of the driver becoming energized while aligning driver and pump. Getting caught in rotating parts of the drive system will cause serious personal injury or death. **DO NOT** start or operate pump without guards in place.

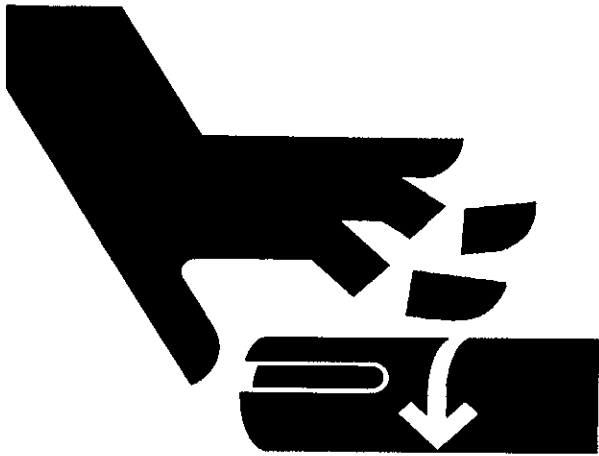

**WARNING!** **DO NOT** operate without guards in place.

There are two forms of misalignment between the driver shaft and the pump shaft. The first is angular misalignment, where the axes of the shafts are concentric but not parallel. The other is parallel misalignment, where the axes of the shafts are parallel but not concentric. Refer to Fig. 2.5.1.

Make the check for angular alignment by inserting the taper gauge or feeler gauges between the coupling faces and comparing the distance between the faces at four points spaced at 90° intervals around the coupling. The unit will be in angular alignment when the measurements show that the coupling faces are the same distance apart at all points.

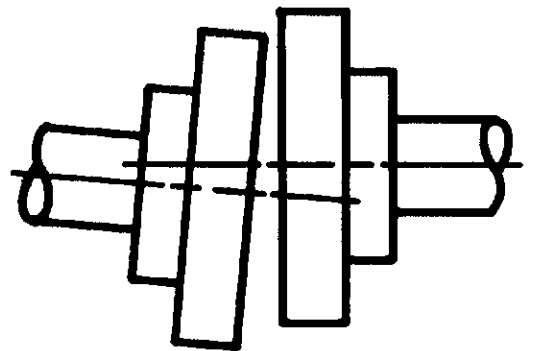
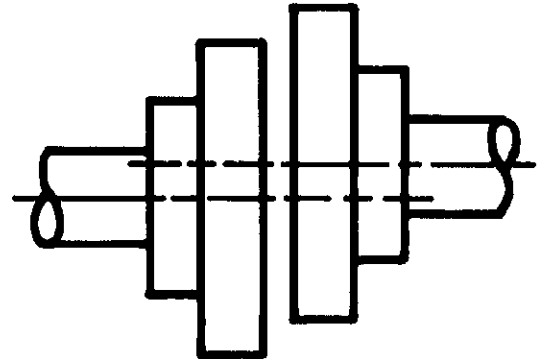
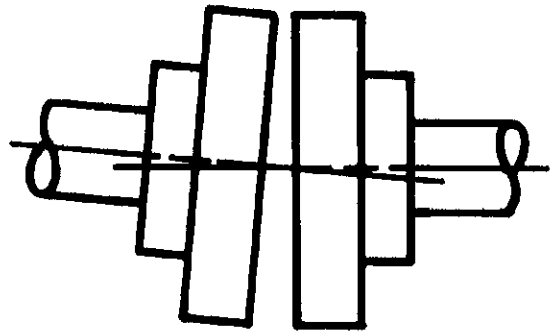

**Fig. 2.5.1 Misalignments: Top, Angular; Center, Parallel; Bottom, Both.**

Make the check for parallel alignment by placing a straight edge across both coupling halves at the top, bottom, and at both sides. The unit will be in parallel alignment when the straight edge rests evenly on the coupling halves at all positions. Allowance may be necessary for temperature changes and for coupling halves that **DO NOT** have the same outside diameter. Take care to have the straight edge parallel to the axes of the shafts. Correct angular and parallel misalignment by placing shims under the mounting feet of the

equipment. After each change, it is necessary to recheck the alignment of the coupling halves. Adjustment in one direction may disturb adjustments already made in another direction.

## BELTS AND SHEAVES

Some applications on gear pumps involving low discharge pressure and slow speeds may permit the mounting of the driven sheave directly on the pump shaft. However, it is recommended that all belt drive assemblies be designed with a separate jackshaft mounted on pillow blocks to carry the side loads of the sheaves and belts and a flexible coupling connecting the jackshaft to the pump shaft.



**Make sure there is no chance of the driver becoming energized while aligning and adjusting the belts. Getting caught in rotating parts of the drive system will cause serious personal injury or death. DO NOT start or operate pump without guards in place.**

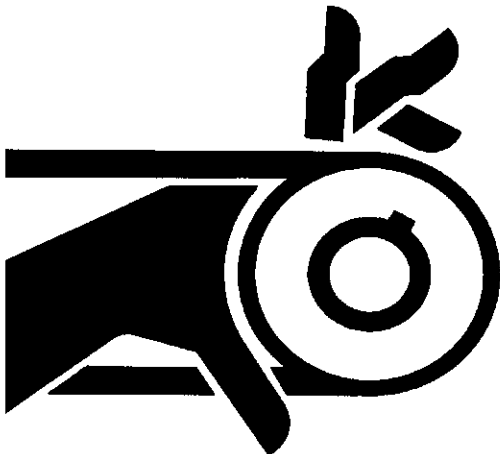

**WARNING! DO NOT operate without guards in place.**

The driver and pump shafts must be parallel, and the belts at right angles to these shafts. Misalignment will cause undue belt wear, or turn-over in the grooves. Approximate alignment should be checked by placing a long straight edge evenly across the rims of

both sheaves. If the faces of the sheaves are not of equal width, the alignment may be checked by resting the straight edge across the rim of the widest sheave and measuring the distance from the straight edge to the nearest belt groove with a scale. Adjust either sheave on the shaft to equalize these dimensions.

The driver should be mounted with adequate provision for belt center distance adjustment. Provide a minus adjustment to permit belt installation without stretching and a plus allowance to provide belt take-up.

**DO NOT** pry, twist, or force the belts over the sheave grooves. This will damage the belts and greatly reduce the belt life. Shorten the drive by moving the driver enough to permit fitting the belts in the proper grooves. When the belts are in place, increase the center distance until proper belt tension is obtained. Adjust take-up until only a slight bow appears on the slack side of the drive when it is operating. All the belts must be pulling evenly. Belt tension should be reasonable. It is not necessary to have belts excessively tight.

During the first few days of operation, the belts will seat themselves in the sheave grooves. After that, the drive must be adjusted to take up the slack. Slipping belts will result in lowered capacity. Squealing or smoking belts are sometimes a clue to the slipping of belts.

Keep belts clean and free from oil. Stop drive to clean belts. **DO NOT** attempt to clean belts while the drive is operating. Clean oily belts with a cloth dampened with soap and water. Never install new belts on the same drive with used belts. **DO NOT** use sheaves with chipped or worn grooves. For hazardous locations, check to see if an antistatic belt should be used. When purchasing replacement belts, the same size and type should be ordered as furnished originally.

## POWER TAKE-OFF DRIVE SYSTEMS

When mounting a pump on a vehicle with a PTO drive, always check with the manufacturer of the PTO equipment to determine the alignment required for proper operation of the PTO. The mount for the pump must be rigid. The pump must be

mounted the way it was designed to be mounted. Pumps with feet must be mounted by the feet. **DO NOT** use the pump ports to mount a pump that has feet. It is acceptable to mount a foot mounted pump in the three, nine, or twelve o'clock position as well as the standard six o'clock position as long as proper shaft alignment is maintained.

## **DANGER**

**Make sure there is no chance of the driver becoming energized while aligning the power take-off shafting. Getting caught in a power take-off drive system will cause serious injury or death. Proper guarding must be provided for all power take-off drive systems.**



**WARNING! DO NOT operate without guards in place.**

Serious injuries and deaths have resulted from persons becoming caught in power take-off (PTO) drive systems. Loose or dangling clothing and slippery or unsure footing are factors in many PTO accidents. **DO NOT** work on or adjust a pump driven by a PTO drive system while it is operating or has a chance of the driver becoming energized except as specified in the section titled, **DIRECTION OF ROTATION** and **RELIEF VALVES**.

Unless properly designed, guarded, and maintained, all drive systems are dangerous.

- **DO** be careful near rotating PTO drive systems. Contacting a PTO drive system may cause serious injury or death.
- **DO** install and maintain proper guard(s) for PTO drive systems.

- **DO NOT** operate PTO drive systems without proper guards in place.
- **DO NOT** work on or adjust a pump driven by a PTO drive system while it is operating or has a chance of the driver becoming energized except as specified in the section titled, **DIRECTION OF ROTATION AND RELIEF VALVES**.
- **DO NOT** work on a PTO drive system while it may become energized.
- **DO NOT** wear loose or dangling clothing or jewelry near the equipment. It could become caught and possibly cause serious injury or death.

### **GUARDING PTO DRIVE SHAFTS**

PTO drive systems can be dangerous and when used, additional safety precautions, including guarding, may be required and must be provided by the drive system installer. Roper Pump Company has no responsibility for recommending or providing proper guarding or other safety measures in any particular application.

The installation of proper guards for the power take-off and its associated equipment is the responsibility of the drive system designer and the installer who know the particular product application and the user's exposure to danger. *The ultimate responsibility for the safe application and installation is the user's.*

### **SPECIAL PRECAUTIONS FOR HYDRAULIC DRIVES**

Avoid contact with high pressure fluids. Check all hydraulic hoses.

Hydraulic hoses can fail due to physical damage, kinks, age, and exposure. Check hoses regularly. Replace damaged hoses.

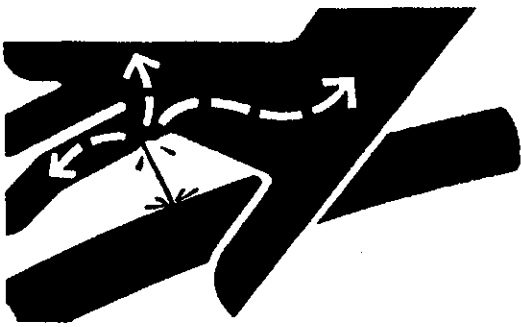

**WARNING!** AVOID CONTACT with high pressure fluids.

## **WARNING**

Escaping fluid under pressure can penetrate the skin causing serious injury. Avoid the hazard by relieving pressure before disconnecting hydraulic or other lines. Tighten all connections before applying pressure. Search for leaks with a piece of cardboard. Protect hands and body from high pressure fluids.

If an accident occurs, see a doctor immediately. Any fluid injected into the skin must be surgically removed within a few hours or gangrene may result. Doctors unfamiliar with this type injury should reference a knowledgeable source.

## **WARNING**

An overload or kickdown valve in a hydraulic drive system is NOT a safe substitute for a pressure relief valve correctly installed in the pump piping system.

## **2.6 ADDITIONAL IMPORTANT WARNINGS AND INFORMATION**

- *This manual contains general information concerning the use, inspection, adjustment,*

*testing and safety considerations of the pump furnished. Other precautions and safety measures may be appropriate depending on the particular application and installation and are the responsibility of the product installer and user. Installers and users of this pump must have sufficient knowledge and training to apply sound safety and operating practices that may not be mentioned in the manual, and Roper's sale of this pump is in reliance on such installer and user knowledge and training.*

- Roper pumps are general purpose pumps for a wide range of uses; yet, *they are not designed nor intended for use with every known substance.* Maximum ratings are shown in the section titled, **MAXIMUM PUMP RATINGS.** Roper sales brochures contain standard ratings. Ratings for SPECification number pumps or standard pumps may be obtained by contacting a Roper distributor or Roper Pump Company.
- Review this manual to determine the proper union of the pump into the total plant or system operating programs.
- *Roper does not supply, recommend, or approve the systems in which its pumps are or may be used.* Unless designed, built, and used properly, systems may be unsafe or dangerous. Installers and users should check and comply with all applicable federal, state, local, and other regulations and recommendations such as: NFPA, UL, OSHA, API, etc.

In particular, installers and users must check the pumped liquid properties and take proper precautions. Among other things, consider the following:

- Decide the results of spillage or leakage (all pumps or systems may fail sometime).
  - \_\_\_ Explosion
  - \_\_\_ Corrosion
  - \_\_\_ Chemical Burns
  - \_\_\_ High Pressure Spray
  - \_\_\_ Toxic Exposure
  - \_\_\_ Fire



- \_\_\_ Exposure to Extreme Temperatures
- \_\_\_ Environmental Impact
- \_\_\_ System Impact
- \_\_\_ Other
- Are proper safeguards being used?
  - \_\_\_ Temperature Controls
  - \_\_\_ Pressure Controls
  - \_\_\_ Leak Detectors
  - \_\_\_ Shutoff Devices
  - \_\_\_ High or Low Pressure Safeguards
  - \_\_\_ Alarm Devices
  - \_\_\_ Overfill or Overflow Detection
  - \_\_\_ Driver Overload Controls
  - \_\_\_ Consider all possible methods and series of failure.
  - \_\_\_ Are any other methods needed to control a hazard?
  - \_\_\_ Regular scheduled inspection for the wear and tear of parts.
- Identify all possible hazards. Decide upon and install the required controls. Only the installer and user can fully understand the product and system characteristics. *The ultimate responsibility for the safety of the application and the system characteristics is with the installer and user.*
- Particularly note the chance of fire and burns from flammable or hot liquid spillage from burst hoses and take proper precautions.
- Properly guard all exposed rotating parts of the drive to the pump.
- Install a pressure relieving device in the system discharge piping to protect the equipment and crew from accident due to too much pressure. **NEVER** place a shutoff valve between the pump and system relief valve. Read Section 2.3, **PREOPERATION CHECKS.**
- Spillage or overflow, from overfilling or putting too much pressure on any

component of a system incorporating this pump, may result in an accident. Proper measures and precautions must be taken to avoid spillage or overflow from overfilling or putting too much pressure on any component of the system. This includes the receiver and lines.

Prior to starting pump, read sections on **PREPARATION OF FOUNDATION; ALIGNING DRIVER AND PUMP; INSTALLATION OF PIPES; THREADED PORT CONNECTIONS; and PREOPERATION CHECKS.**

## **2.7 INSTALLATION OF PIPES**

- **DO NOT** connect raised face flanges to the ports of a cast iron pump.
- **DO** use flat faced flanges with cast iron pumps.

Piping must be installed and checked carefully. Allow for any expansion or contraction.

Any external force or moment (torque or twist) applied on the pump ports by the piping will cause stresses in the pump and its foundation. This may cause misalignment that could result in hot bearings, worn couplings, or excessive vibration. Such forces or moments may be caused by improperly aligned piping or by thermal expansion of the piping when pumping hot or cold fluids. The piping should be supported independently. Use flexible piping connectors and insure that they are properly anchored.

If an expansion joint is installed in the piping between the pump and the nearest point of anchor in the piping, a force equal to the area of the expansion joint (which may be considerably larger than the normal pipe size) times the pressure in the pipe will be transmitted directly to the pump. Pipe couplings that **DO NOT** provide an axially rigid connection have the same effect. This reaction force can be so large that it would be impractical to design suitable components to withstand the force. If an expansion joint or nonrigid coupling is used, install a pipe anchor

between it and the pump. If properly installed, this will eliminate the forces mentioned above.

The pump port size does not necessarily establish the correct pipe size. Piping must be sized and arranged to provide ample inlet pressure at the pump and to insure that the discharge pressure will be at least as low as the rated pressure of the pump. If the fluid to be pumped is viscous, or the piping long, or the suction lift or static discharge head somewhat high, piping one or two sizes larger may be required. Friction losses should be carefully calculated (see Hydraulic Institute Engineering Data Book or similar authority for friction loss data) and compared to the pump ratings before the installation is made. Where valves are used in the piping system, gate, ball, or butterfly valves are preferable to globe or angle valves. 90° long radius elbows or 45° elbows are preferable to standard short radius elbows. **NEVER** place a valve between the pump and system relief valve.

## **2.8 THREADED PORT CONNECTIONS**

---

American National Standard Taper Pipe Threads (NPT) are standard for pipe plugs and threaded ports of the pump ports. British Standard Pipe Threads (BSP) are available on request for most sizes.

To produce a pressure tight joint, a thread sealant must be used. TFE tape is generally not recommended where cast iron is used as one or more parts of the joint. The use of TFE tape for installing cast iron fittings may cause damage to the pump or fittings.

The following is a partial list of sealants that may be used when making up joints on the pump:

- PST Pipe Sealant No. 567 - Loctite Corp.
- Rectorseal No. 5 - The Rectorseal Corp.
- Leak Lock - Highside Chemical, Inc.

Follow the sealant manufacturer's instructions when making up a joint.

## 2.9 CHECKING PUMP PERFORMANCE

A summary of the causes of common malfunctions.

PROBLEM	POSSIBLE CAUSES
<b>NO LIQUID DELIVERED</b>	Pump rotating in wrong direction.
	Pump not primed.
	Inlet lift too high. Check this with gauge at pump inlet.
	Clogged inlet line.
	Inlet pipe not submerged.
	Air leaks in inlet line.
	Faulty pressure relief device in system. Pump Worn.
<b>RAPID WEAR</b>	Excessive pressure.
	Nonlubricating liquid.
	Pump runs dry.
	Incompatibility of liquid and pump materials.
	Pipe strain on pump. See Section 2.7, Installation of Pipes. Excessive abrasives in liquid.
<b>EXCESSIVE NOISE</b>	Starved Pump.
	Air leaks in inlet line.
	Air or gases in liquid.
	Pump speed too high.
	Relief valve chatter. Check pressure setting.
	Improper mounting. Check alignment thoroughly. See Section 2.4, Aligning Driver and Pump and Section 2.5, Preparation of Foundation.
<b>PUMP TAKES TOO MUCH POWER</b>	Speed too high.
	Liquid more viscous than previously anticipated.
	Operating pressure higher than specified. Check this with gauge at pump discharge.
	Discharge line obstructed.
	Mechanical defect, such as bent shaft.
	Pipe strain on pump. See Section 2.7, Installation of Pipes.
	Pressure relief device not operating properly. Air leaks in inlet line.
<b>INSUFFICIENT LIQUID DELIVERED</b>	Air leaks through mechanical seal.
	Speed too slow.
	Excessive lift at inlet. Check this with gauge at pump inlet.
	Viscosity of liquid too high for size and length of inlet pipe.
	Foot valve, if used, too small, stuck, or not working properly.
	Foot valve or end of inlet pipe not immersed deeply enough in liquid.
	Excessive clearance in pump caused by wear or corrosion. Faulty pressure relief device.



## 2.11 INDEX

---

### A

#### Aligning Shafts

- Belts and Sheaves, 2 - 7
- Flexible Coupling, 2 - 5 through 2 - 7
- Power Take-Off, 2 - 8
- Pump and Driver, 2 - 5 through 2 - 8

### F

- Foundation, 2 - 4 through 2 - 5

### G

- Guarding Power Take-Off Shafts, 2 - 8

### I

- Installation of Pipes, 2 - 10 through 2 - 11

### P

- Pipe Installation, 2 - 10 through 2 - 11
- Pipe Threads - Threaded Port Connections, 2 - 11
- Problems and Causes, 2 - 12
- Preoperation Checks, 2 - 3 through 2 - 4

### R

- Replacement Parts, 2 - 13

### S

- Safety Precautions, 2 - 2 through 2 - 3, 2 - 9 through 2 - 10

### T

- Threaded Port Connections, 2 - 11

## SECTION 3.0

# TABLE OF CONTENTS

<b>SECTION</b>		<b>PAGE</b>
3.1	Safety Signal Words and Symbols .....	3 - 1
3.2	Recommended Tool List.....	3 - 1
3.3	Direction of Rotation for Standard Drive Pumps.....	3 - 2
3.4	Direction of Rotation for Mag Drive Pumps .....	3 - 3
3.5	Instructions for Draining Pump.....	3 - 4
3.6	Instructions for Standard Drive Pump Disassembly.....	3 - 4
3.7	Instructions for Mag Drive Pump Disassembly .....	3 - 5
3.8	Dimensional Data for Internal Parts.....	3 - 7
3.9	Instructions for Standard Drive Pump Assembly.....	3 - 7
3.10	Instructions for Mag Drive Pump Assembly .....	3 - 8
3.11	Pump Sectional Drawings .....	3 - 10
3.12	Parts List.....	3 - 12
3.13	Shaft Sealing.....	3 - 13
3.14	Common Maintenance Questions.....	3 - 16
3.15	Index.....	3 - 18

## **3.1 SAFETY SIGNAL WORDS AND SYMBOLS**

---

### **SAFETY SIGNAL WORDS**

The safety signal words **CAUTION!**, **WARNING!**, **DANGER!**, and **TOXIC!** Have specific meanings in this manual.

**CAUTION!** Is used to identify hazards that may cause damage to property or equipment.

**WARNING!** Is used to identify hazards that may cause personal injury.

**DANGER!** Identifies the most serious hazards. **DANGER!** Is used to identify hazards that will cause personal injury, or death.

**TOXIC!** Identifies hazards that involve materials that may cause death by contact, ingestion, or inhalation. **TOXIC!** Will always be used with the safety signal word **DANGER!**

## **3.2 RECOMMENDED TOOL LIST**

---

**NOTE: Tools not furnished with pump.**

### **Tools for all Pumps:**

- (1) Safety Glasses
- (1) Rubber Mallet
- (1) 1/2" Combination Wrench
- (1) Pliers
- (1) 7/16" Combination Wrench

### **Additional Tools for Pumps with Mag Drive Coupling:**

- (1) 0200 Retaining Ring Pliers

### **Additional Tools for Pumps with Shaft Packing:**

Packing Hook for .29" square packing rings

- (1) 3/4" Combustion Wrench

### **Additional Tools for Pumps with Mechanical Seals:**

- (1) 3/32" Hex Key
- (1) 0200 External Retaining Ring Pliers
- (1) 3/4" Combination Wrench
- (1) 0200 Retaining Ring Pliers

### 3.3 DIRECTION OF ROTATION FOR STANDARD DRIVE PUMPS

Prior to operating the pump, make sure that the shaft rotation and pipe connections are in accordance with the following instructions and illustrations.

The standard drive pumps in sizes X5 through 03 can operate in either direction of rotation and in low or high drive

Low drive indicates that the drive shaft is lower than the pump ports. High drive indicates that the drive shaft is higher than the pump ports.

The arrow in the drawing at the end of the drive shaft indicates the direction of rotation needed to achieve proper operation of the pump when using the pump orientation shown in the drawing. CW indicates clockwise rotations and CCW indicates counterclockwise rotation when viewed from the drive shaft end of the pump.

STANDARD DRIVE PUMPS		
LOW DRIVE	ROT	HIGH DRIVE
 <p>DISCHARGE</p> <p>INLET</p> <p>standard</p>	C W	 <p>INLET</p> <p>DISCHARGE</p>
 <p>INLET</p> <p>DISCHARGE</p>	C C W	 <p>DISCHARGE</p> <p>INLET</p>

FIGURE 3.3.1



### 3.4 DIRECTION OF ROTATION FOR MAG DRIVE PUMPS

Prior to operating the pump, make sure that the shaft rotation and pipe connections are in accordance with the following instructions and illustrations.

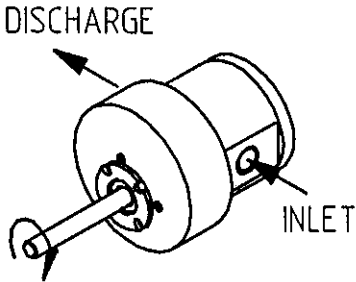
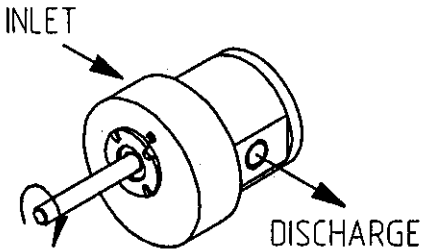
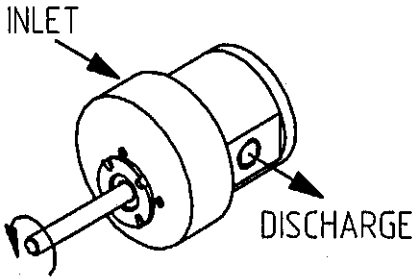
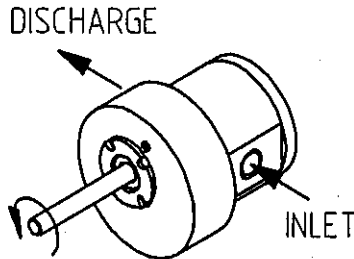
The mag drive pumps in sizes X5 through 03 are made to operate in a specific direction of rotation. The mag drive pumps can either be ordered for clockwise rotation or for counterclockwise rotation. Low drive indicates that the drive shaft is lower than the pump ports. High drive indicates that the drive shaft is higher than the pump ports.

The arrow in the drawing at the end of the drive shaft indicates the direction of rotation needed to achieve proper operation of the pump when using the pump orientation shown in the drawing. CW indicates clockwise rotations and CCW indicates counterclockwise rotation when viewed from the drive shaft end of the pump.

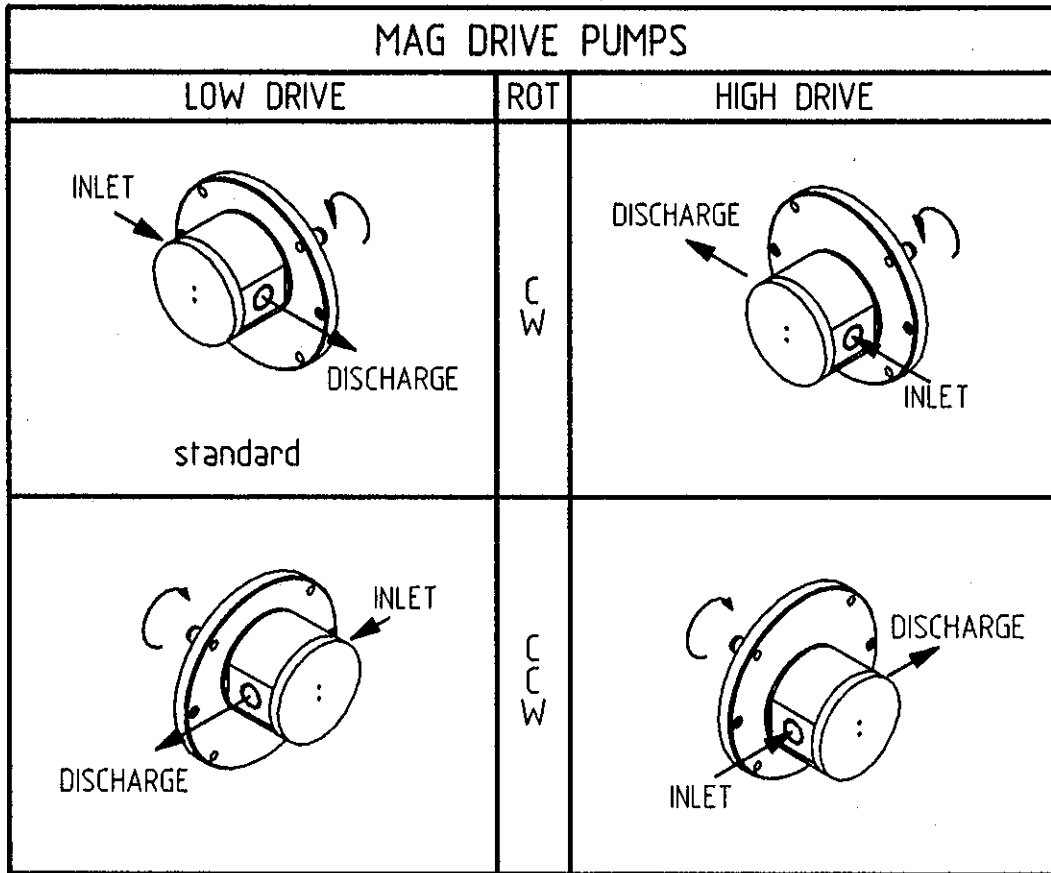

FIGURE 3.3.2

Mag drive pumps will have the inlet side designated by a metal tag which reads INLET, attached to the pump backplate.

A mag drive pump build for CW shaft rotation can be used in the low drive or high drive orientation, likewise, a pump built for CCW shaft rotation can be used in the low drive or high drive orientation.

## 3.5 INSTRUCTIONS FOR DRAINING PUMP

---

Refer to Section 3.11, **PUMP SECTIONAL DRAWINGS**.

### **WARNING**

- **WARNING!** Relieve all internal fluid and air pressure inside the pump before attempting to drain the pump.
- **WARNING!** Take necessary precautions to prevent the pump from becoming energized while draining the pump.
- **WARNING!** Take necessary precautions to prevent injury or physical damage that could be caused by any loss of the product being pumped while draining the pump.

The extent to which a pump can be drained is dependent upon the product being pumped. Low viscosity products such as solvents will drain quickly and easily. High viscosity products such as molasses and tar will drain very slowly. Also, the draining of high viscosity products will be less complete

Regardless of the product pumped, the areas at the blind end of the bearing bores and the mechanical seal chamber will not drain.

1. Refer to Section 2.0 and read sections on **SAFETY PRECAUTIONS** and **ADDITIONAL IMPORTANT WARNINGS AND INFORMATION** before starting procedures.
2. Loosen four hex head cap screws (14) securing faceplate (2) to allow a gap of 1/8 of an inch [3 mm] between faceplate and case (1) for draining.
3. Rotate drive shaft very slowly by hand. Each time that flow from drain increases; stop turning shaft until flow stops; then resume until flow increases again. Be sure to rotate shaft several complete

revolutions in each direction until all flow from drain has stopped.

4. After draining has been completed, examine case (1) making sure o-ring is not torn prior to tightening the four hex head cap screws (14). If o-ring is torn or further disassembly is required, follow steps in Sections 3.6, **INSTRUCTIONS FOR STANDARD DRIVE PUMP DISASSEMBLY** and 3.7, **INSTRUCTIONS FOR MAG DRIVE PUMP DISASSEMBLY** to replace o-rings.

## 3.6 INSTRUCTIONS FOR STANDARD DRIVE PUMP DISASSEMBLY

---

Refer to Section 3.11, **PUMP SECTIONAL DRAWINGS**.

1. Read Section 2.0 on **SAFETY PRECAUTIONS** and **ADDITIONAL IMPORTANT WARNINGS AND INFORMATION** before starting to disassemble pump. While disassembling pump, always inspect disassembled parts and adjacent parts to see if further disassembly is needed. Replace worn or damaged parts as required. Read Section 2.0, **REPLACEMENT PARTS**.
2. If you do not know which pump arrangement you have, collect nameplate data and refer to Section 1.0, **NAMEPLATE DATA**, to determine what you have. Consult a Roper distributor or Roper Pump Company if you have any questions.
3. When cleaning or lubricating, use only cleaning solutions and lubricants that are compatible with products being pumped and with sealing elastomers. **DO NOT** use petroleum base products with seals with EPR elastomers. Use a nonpetroleum based lubricant with EPR elastomers.
4. Turn off pump and lock out energy source to driver. **DO NOT** proceed further with disassembly of pump if there is the

slightest possibility that driver may be started.

5. If used, turn off and disconnect flush from mechanical seal.
6. Close inlet and discharge valves.
7. Remove guard and disconnect coupling between driver and pump.
8. Drain inlet and discharge lines. Disconnect lines from pump inlet and discharge.
9. Follow procedure in Section 3.5,  
**INSTRUCTIONS FOR DRAINING PUMP.**
10. Remove three locknuts from bracket and remove pump from mounting.
11. Remove four hex head cap screws (14) to remove faceplate (2).
12. Slide case (1) off of drive gear (4) and bearings (6) on backplate end of pump. Idler gear (5) and bearings (6) on faceplate end of pump will usually remain in case (1). Remove o-rings (12) from backplate (3) and faceplate (2).
13. Remove idler gear (5) from case (1) and push drive and idler bearing (6) out of case.
14. Remove idler bearing (5) at backplate end of pump.

### **PUMPS EQUIPPED WITH MECHANICAL SHAFT SEALS**

15. Remove four locknuts (33) from seal retainer (9). Remove seal retainer and stationary seal face (8). Remove o-ring (11) from seal face (8).
16. When removing following types of single seals (John Crane® Type 9T, Type 8-1T, Type 21; Pac-Seal® Type 21), clean and lubricate drive shaft (4) prior to removing mechanical seal, making sure that drive shaft is smooth and free from all burrs. Loosen setscrews (if present) on mechanical seal. Access to mechanical

seal setscrews is obtained by removing plug (17) in side of backplate (3).

17. Push coupling end of drive shaft (4) toward backplate (3) until end of shaft is flush with backplate. Shaft may be difficult to move at first because this procedure is used to push retaining ring (10) from groove in drive shaft (4).
18. Push drive gear (4) end toward backplate (3) so that mechanical seal (7) is exposed. Slide mechanical seal off shaft and remove retaining ring (10). Slide drive gear/shaft out of backplate (3) and remove bearing (6) from shaft.

### **PUMPS EQUIPPED WITH SHAFT PACKING**

19. Remove four locknuts (33) from packing plate (9). Remove packing plate (9) and packing gland (8).
20. Push coupling end of drive shaft (4) toward backplate (3). Slide drive gear/shaft out of backplate and remove bearing (6) from shaft.
21. Remove packing rings (7) from backplate (3).

## **3.7 INSTRUCTIONS FOR MAG DRIVE PUMP DISASSEMBLY**

---

Refer to Section 3.11, **PUMP SECTIONAL DRAWINGS.**

1. Read Section 2.0 on **SAFETY PRECAUTIONS** and **ADDITIONAL IMPORTANT WARNINGS AND INFORMATION** before starting to disassemble pump. While disassembling pump, always inspect disassembled parts and adjacent parts to see if further disassembly is needed. Replace worn or damaged parts as required. Read Section 2.0, **REPLACEMENT PARTS.**
2. If you do not know which pump arrangement you have, collect nameplate

data and refer to Section 1.0, **NAMEPLATE DATA**, to determine what you have. Consult a Roper distributor or Roper Pump Company if you have any questions.

3. When cleaning or lubricating, use only cleaning solutions and lubricants that are compatible with products being pumped and with sealing elastomers. **DO NOT** use petroleum base products with seals with EPR elastomers. Use a nonpetroleum based lubricant with EPR elastomers.
4. Turn off pump and lock out energy source to driver. **DO NOT** proceed further with disassembly of pump if there is the slightest possibility that driver may be started.
5. Close inlet and discharge valves.
6. Drain inlet and discharge lines. Disconnect lines from pump inlet and discharge.
7. Follow procedure in Section 3.5, **INSTRUCTIONS FOR DRAINING PUMP.**

## **WARNING**

**This pump contains strong magnetic fields. Keep away from pacemakers and other medical equipment that is sensitive to magnetic fields.**

8. It is recommended that a clean work area and surface be provided when disassembling the pump. The strong magnets in this pump will pick up loose ferrous particles and tools that are several inches away.
9. Remove four cap screws (28) securing backplate (3) to bracket (24). Using two 5/16-18 UNC x 2.5 inch long jackscrews (29) in holes provided in backplate (3), jack backplate (3) from bracket (24).

- **WARNING! DO NOT** attempt to disengage or engage the magnetic rotors without the use of jackscrews. Personal injury and/or equipment damage could result. **NEVER** allow the inner and outer magnetic rotors to be closer than two feet from each other when pump is disassembled. These magnets are very strong and must be handled carefully to prevent personal injury and/or equipment damage.
10. Remove six cap screws (31) securing containment barrier (21) to backplate (3). Using a soft face striking tool, gently tap containment barrier (21) to break seal of containment barrier to backplate.
  11. Remove o-ring (20) from backplate (3).
  12. Remove retaining ring (10) holding inner magnetic rotor (23) on drive shaft (4). Remove inner magnetic rotor (23).
  13. Remove drive key (16).
  14. Remove retaining ring (10) from drive shaft (4).
  15. Remove four hex head cap screws (14) securing faceplate (2) and case (1) to backplate (3).
  16. Slide case (1) off of drive gear (4) and bearings (6) on backplate end of pump. Idler gear (5) and bearings (6) on faceplate end of pump will usually remain in case (1). Remove o-rings (12) from case.
  17. Remove idler gear (5) from case (1) and push drive and idler bearing (6) out of case.
  18. Remove idler bearing (6) at backplate end of pump.
  19. Slide drive gear/shaft (4) out of backplate (3) and remove bearing (6) from shaft (4).
  20. Remove four cap screws (26) securing bracket (24) to motor.

21. Loosen setscrews (32) securing outer magnetic rotor (22) to motor drive shaft. Remove outer magnetic rotor (22). **NEVER** allow the inner and outer magnetic rotors to be closer than two feet from each other when pump is disassembled. These magnets are very strong and must be handled carefully to prevent personal injury and/or equipment damage.
22. Visually inspect all parts. Replace all worn or damaged parts before reassembling pump. It is recommended that new o-rings (12, 20) be installed each time pump is disassembled and reassembled.

### 3.8 DIMENSIONAL DATA FOR INTERNAL PARTS

Nominal dimensions are given below. With the exception of gasket thickness and lateral clearance, your actual measurements should not vary from these numbers by no more than .0005". Use properly calibrated measuring equipment when measuring parts.

ITEM	PUMP SIZE			
	X5	01	02	03
Case Bore	1.133	1.133	1.133	1.133
Gear O.D.	1.1245	1.1245	1.1245	1.1245
Gear O.D. to Case Bore Dia. Clearance	.0085	.0085	.0085	.0085
Bearing I.D.	.503	.503	.503	.503
Shaft O.D.	.4995	.4995	.4995	.4995
Shaft O.D. to Bearing I.D. Dia. Clearance	.0035	.0035	.0035	.0035
Case Width	1.7160	1.9375	2.375	2.875
Bearing Width (one)	.7495	.7495	.7495	.7495
Gear Face Width	.2145	.4360	.8735	1.3735
Pump Lateral Clearance	.0025	.0025	.0025	.0025

### 3.9 INSTRUCTIONS FOR STANDARD DRIVE PUMP ASSEMBLY

Refer to Section 3.11, **PUMP SECTIONAL DRAWINGS**.

Refer to Section 3.3, **DIRECTION OF ROTATION FOR STANDARD DRIVE PUMPS** prior to assembling pump.

1. Refer to Section 2.0 and read instructions on **REPLACEMENT PARTS, THREADED PORT CONNECTIONS, SHAFT SEALING**, and **SAFETY PRECAUTIONS** before assembling pump. Visually inspect all parts during assembly. Replace all worn or damaged parts. Although they may appear reusable, it is recommended that new o-rings (11, 12, 18) be installed when pump is being reassembled.
2. When cleaning or lubricating, only use products that are compatible with product being pumped and elastomers within pump. **DO NOT** use petroleum base products with seals with EPR elastomers. Clean and lubricate parts with light oil unless EPR elastomers are used. Use a nonpetroleum base lubricant with EPR elastomers.
3. Mechanical seals are precision pieces of equipment. Use extreme care not to damage seal faces or elastomers during assembly.
4. Install two dowel pins (13) in backplate (3).
5. Install two bearings (6) in end of case (1) that contains the dowel holes.
6. Install o-ring (12) in dowel hole side of backplate (3).
7. Fit case (1) and backplate (3) together on dowel pins (13). Be sure o-ring (12) is positioned in groove.
8. Install drive gear/shaft (4) and idler gear/shaft (5) in case bores.
9. Install two bearings (6) over drive and idler shafts in case bores.

10. Install o-ring (12) in faceplate (2).
11. Attach faceplate (2) using four hex head cap screws (14).

### **PUMPS EQUIPPED WITH MECHANICAL SHAFT SEALS**

12. Install retaining ring (10) on drive shaft (4).
13. When installing following types of single seals (John Crane® Type 9T, Type 8-1T, Type 21; Pac-Seal® Type 21), clean and lubricate drive shaft (4) prior to installation, making sure that drive shaft is smooth and free from all burrs.
14. a. To install a John Crane® Type 9T or Type 8-1T, slide rotating member of seal over drive shaft with lapped seal face facing out of pump. Before sliding seal into seal chamber, remove metal clips that are held in place by tape around outside diameter of seal. After clips have been removed, slide seal down to retaining ring (10). Using an Allen wrench of appropriate size, reach through access hole in side of backplate and tighten all setscrews in mechanical seal.

- b. To install a John Crane® Type 21; Pac-Seal® Type 21, slide rotating member of seal over drive shaft and down to retaining ring (10) with lapped face facing out of pump.

15. Install o-ring (11) over lapped end of stationary seal face (8).
16. Slide stationary seal face (8) over drive shaft and into seal chamber of backplate.
17. Place seal retainer (9) over exposed end of stationary seal face and install four locknuts (33). Be sure to tighten nuts evenly by alternating from one side to other.
18. Install access plug (17) in backplate (3).

### **PUMPS EQUIPPED WITH SHAFT PACKING**

19. Refer to Section 3.13, **SHAFT SEALING, CARE OF PACKING** for proper installation of packing rings.
20. Slide packing gland (8), large end first, over shaft (4) and into bore of backplate (3).

21. Slide retainer plate (9) over small end of packing gland (8).
22. Install four locknuts (33) to attach retainer plate (9) to backplate (3). **DO NOT** tighten locknuts (33).
23. Refer to Section 3.13, **SHAFT SEALING, CARE OF PACKING** for proper procedure for adjusting packing.

## **3.10 INSTRUCTIONS FOR MAG DRIVE PUMP ASSEMBLY**

Refer to Section 3.11, **PUMP SECTIONAL DRAWINGS**.

Refer to Section 3.4, **DIRECTION OF ROTATION FOR MAG DRIVE PUMPS** prior to assembling pump.



**This pump contains strong magnetic fields. Keep away from pacemakers and other medical equipment that is sensitive to magnetic fields.**

1. Refer to Section 2.0 and read instructions on **REPLACEMENT PARTS, THREADED PORT CONNECTIONS, SHAFT SEALING**, and **SAFETY PRECAUTIONS** before assembling pump. Visually inspect all parts during assembly. Replace all worn or damaged parts. Although they may appear reusable, it is recommended that new o-rings (12, 20) be installed when pump is being reassembled.
2. When cleaning or lubricating, only use products that are compatible with product being pumped and elastomers within pump. **DO NOT** use petroleum base products with seals with EPR elastomers. Clean and lubricate parts with light oil unless EPR elastomers are used. Use a nonpetroleum base lubricant with EPR elastomers.
3. Install two dowel pins (13) in backplate (3).

4. Install two bearings (6) in end of case (1) that contains the dowel holes.
  5. Install o-ring (12) in dowel hole side of backplate (3).
  6. Fit case (1) and backplate (3) together on dowel pins (13). Be sure o-ring (12) is positioned in groove.
  7. Install drive gear/shaft (4) and idler gear/shaft (5) in case bores.
  8. Install two bearings (6) over drive and idler shafts in case bores.
  9. Install o-ring (12) in faceplate (2).
  10. Attach faceplate (2) using four hex head cap screws (14).
  11. Install retaining ring (10) on drive shaft (4).
  12. Install drive key (16).
  13. Slide inner magnetic rotor (23) on drive shaft (4). Secure inner magnetic rotor to drive shaft using retaining ring (10). **NEVER** allow the inner and outer magnetic rotors to be closer than two feet from each other while pump is disassembled. These magnets are very strong and must be handled carefully to prevent personal injury and/or equipment damage. **CAUTION!** Be sure all foreign matter is removed from inner magnetic rotor.
  14. Install o-ring (20) in groove in backplate (3).
  15. Position containment barrier (21) on pilot diameter of backplate (3). Secure containment barrier on pilot diameter of backplate (3). Secure containment barrier in place using six cap screws (31) making sure not to damage o-ring (20).
  16. Slide outer magnetic rotor (22) on motor shaft. Measure from face of motor 3.9/3.94 inches [99/100 mm] to face of outer magnetic rotor (22). Tighten the setscrews (32) to secure outer magnetic rotor (22) on motor shaft.
  17. Secure bracket (24) to face of motor using four cap screws (26).
- **WARNING! DO NOT** attempt to disengage or engage the magnetic rotors without the use of jackscrews. Personal injury and/or equipment damage could

result. **NEVER** allow the inner and outer magnetic rotors to be closer than two feet from each other when pump is disassembled. These magnets are very strong and must be handled carefully to prevent personal injury and/or equipment damage.

18. Screw the two 5/16 -18 UNC x 2.5 inch long threaded jackscrews (29) the entire length into backplate (3). Slowly begin to back jackscrews (29) out of backplate (3) allowing inner magnetic rotor (23) which is enclosed in containment barrier (21) to engage in outer magnetic rotor (22). Secure bracket (24) to pump using four cap screws (28).
19. Read sections on **ADDITIONAL IMPORTANT WARNINGS AND INFORMATION, THREADED PORT CONNECTIONS, INSTALLATION OF PIPES, and PREOPERATION CHECKS** before installing and operating pump.

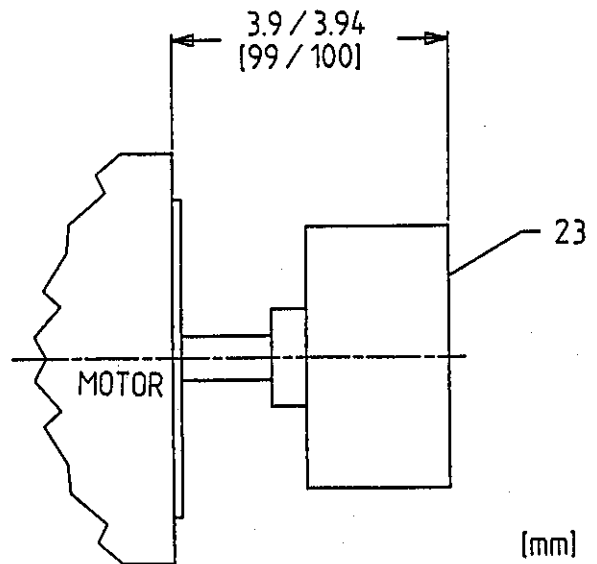

# 3.11 PUMP SECTIONAL DRAWINGS

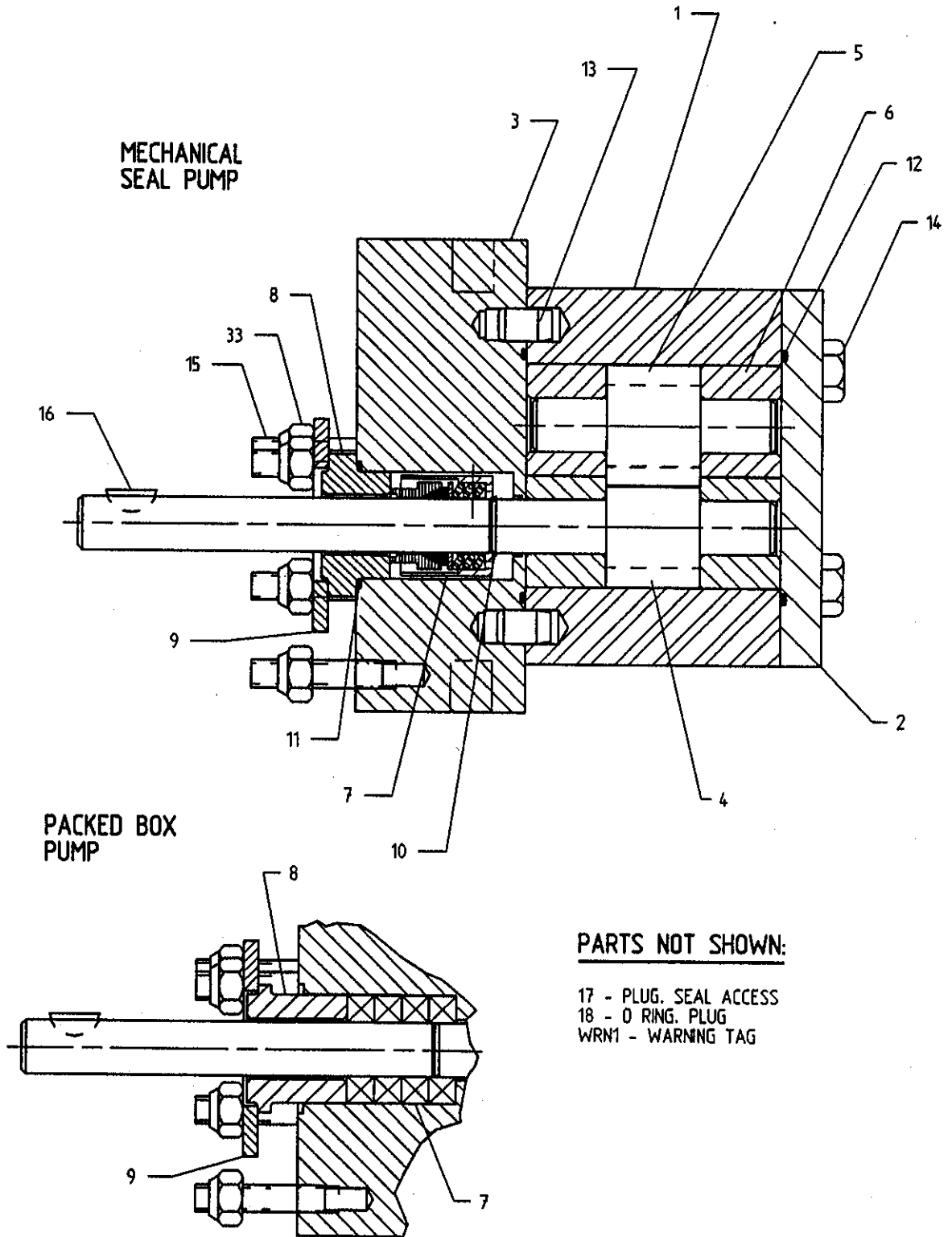

**FIGURE 3.11.1**



**MAG DRIVE PUMP**

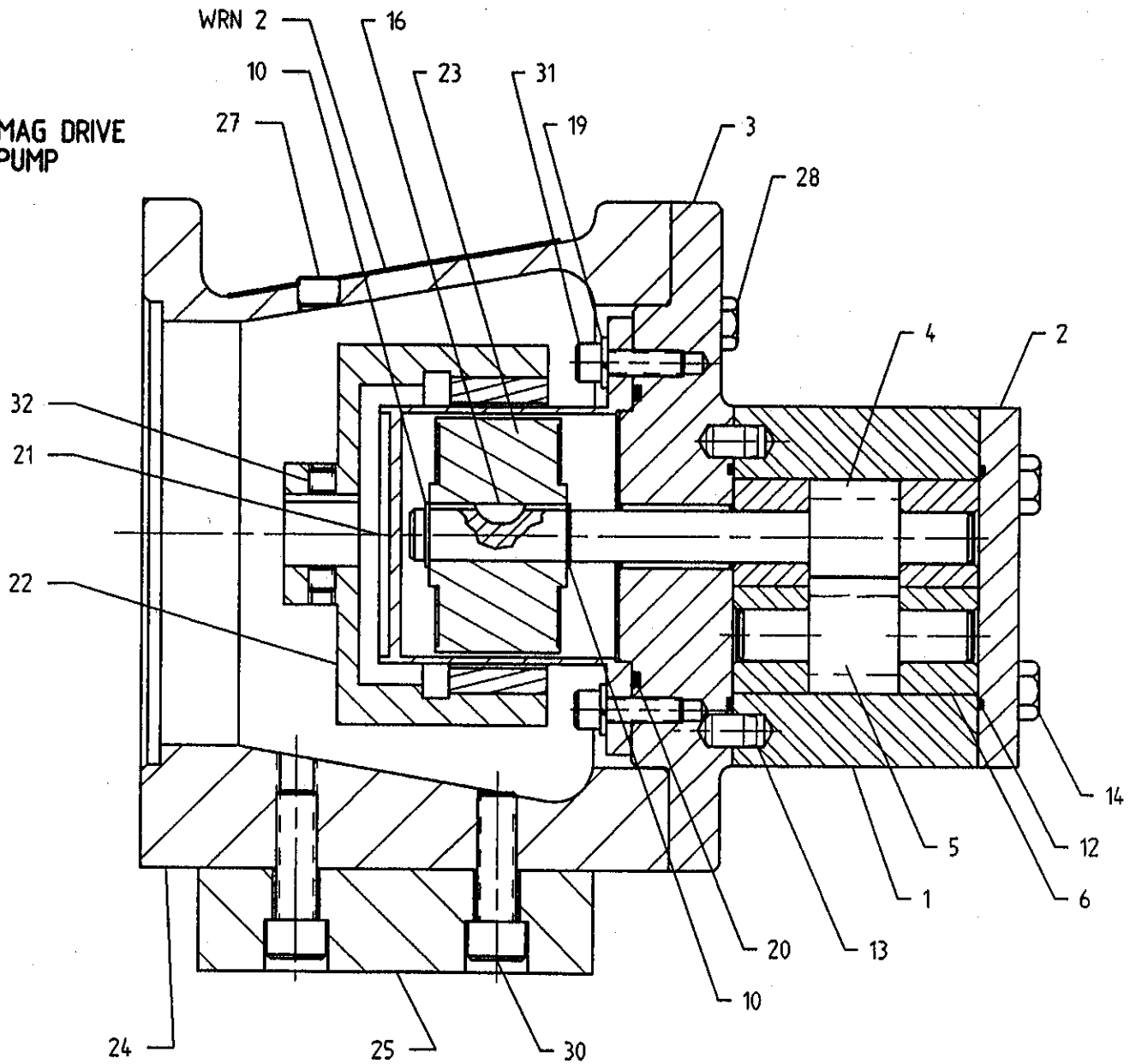

**PARTS NOT SHOWN:**

- 26 - CAP SCREW (BRKT TO MOTOR)
- 29 - JACKSCREW

**FIGURE 3.11.2**

## **3.12 PARTS LIST**

---

### **MECHANICAL SEAL PUMP**

1. Case
2. Faceplate
3. Backplate
4. Drive Gear & Shaft
5. Idler Gear & Shaft
6. Bearing
7. Mechanical Seal
8. Stationary Seal Face
9. Retainer Plate
10. Retaining Ring
11. O-ring, Seal Face
12. O-ring, Case
13. Dowel Pin
14. Hex Head Cap Screw
15. Stud
16. Key
17. Plug, Seal Access
33. Locknut

WRN 1. Warning Plate

### **PACKED BOX PUMP**

1. Case
2. Faceplate
3. Backplate
4. Drive Gear & Shaft
5. Idler Gear & Shaft
6. Bearing
7. Packing Ring
8. Packing Gland
9. Retainer Plate
10. N/A
11. N/A
12. O-ring, Case
13. Dowel Pin
14. Hex Head Cap Screw
15. Stud
16. Key
17. Plug, Seal Access
33. Locknut

WRN 1. Warning Plate

### **MAG DRIVE PUMP**

1. Case
2. Faceplate
3. Backplate
4. Drive Gear & Shaft
5. Idler Gear & Shaft
6. Bearing
7. N/A
8. N/A
9. N/A
10. Retaining Ring, Outer & Inner
11. N/A
12. O-ring, Case
13. Dowel Pin
14. Hex Head Cap Screw
15. N/A
16. Key
17. N/A
18. N/A
19. Washer
20. O-ring, Containment Barrier
21. Containment Barrier
22. Outer Magnetic Rotor
23. Inner Magnetic Rotor
24. Bracket
25. Foot, Bracket
26. Hex Head Cap Screw (Bracket to Motor)
27. Pipe Plug (Bracket)
28. Hex Head Cap Screw (Bracket to pump)
29. Jackscrew
30. Socket Head Cap Screw (Foot to bracket)
31. Socket Head Cap Screw (Containment Barrier to backplate)
32. Setscrew
33. N/A

WRN 2. Warning Plate

## 3.13 SHAFT SEALING

### STANDARD COMPRESSION PACKING

One type of shaft sealing used in these pumps is formed ring packing with or without a lantern ring. When using a packed box pump, use formed packing rings. **DO NOT** use a one piece spiral wrap of packing. Packing rings are available in a wide selection of materials for various applications and temperatures. Previous experience with the pumped fluid is the best guide in selecting the proper packing ring material for your particular application.

### CARE OF PACKING



**DO NOT** work on or adjust packing while the pump is running.

If motor driven, **TURN OFF** motor and lock out the energy source.

**CLOSE VALVES** on the Inlet and discharge while working on the pump.

Packing hooks are commercially available to help in removing packing rings from the stuffing box. It is generally not recommended to reuse old packing rings. When installing packing, use formed packing rings. **DO NOT** use a one piece spiral wrap of packing. Before installing packing, carefully clean the stuffing box and shaft.

Packing rings should be installed one ring at a time, with the joints of adjacent rings staggered approximately 180°. Each ring should be seated firmly before the next ring is installed. **DO NOT** forget to install the lantern ring if applicable. Three rings of packing, followed by the lantern ring, should allow the lantern ring to be approximately aligned with the flush/lube holes in the stuffing box.

The packing gland nuts should first be evenly tightened with a wrench to seat the packing firmly in the stuffing box and against the shaft. **DO NOT** over-tighten the packing. The gland

nuts should then be backed off until finger-tight. After the pump is started, note the stuffing box. If the packing leakage exceeds ten drops per minute, stop the pump and adjust the gland nuts. The gland nuts should be adjusted evenly in 1/6 to 1/3 turn (1 to 2 flats on the nut) increments. Start the pump and allow it to operate for several minutes. Again, visually examine the stuffing box for excessive leakage. Repeat the above procedure until the stuffing box leakage is between five to ten drops per minute.

**DO NOT** over-tighten the packing. Slight leakage is a necessary requirement for proper packing operation. Leakage of five to ten drops per minute when the pump is operating is desirable, as it will preserve the packing and avoid scoring of the shaft. Over-tight packing may score shafts, increase torque requirements of the pump, damage couplings and drivers, and generate excessive heat.

The pump should be stopped and the packing gland adjusted whenever leakage exceeds ten drops per minute. The condition of the packing should be checked at regular intervals, the frequency depending on the type of service. Experience will dictate how frequently the inspections should be made.

### MECHANICAL SEALS

Various types of mechanical seals are available to fit most pumps. (See **VARIOUS SEALING ARRANGEMENTS** (Figure 3.13.3 and 3.13.4). Due to the various seal types and styles available, the seal manufacturer's instructions for installation and setting should be followed when available.

**NOTE:** Not all seals will fit or function in all pumps. Modification to the pump backplate, drive shaft, and/or retainer may be required. Consult with a Roper distributor or Roper Pump Company if you are considering a seal change in your pump.

For removal or installation of mechanical seals, refer to disassembly and assembly procedures for pumps.

# SEAL CHAMBER DIMENSIONALS

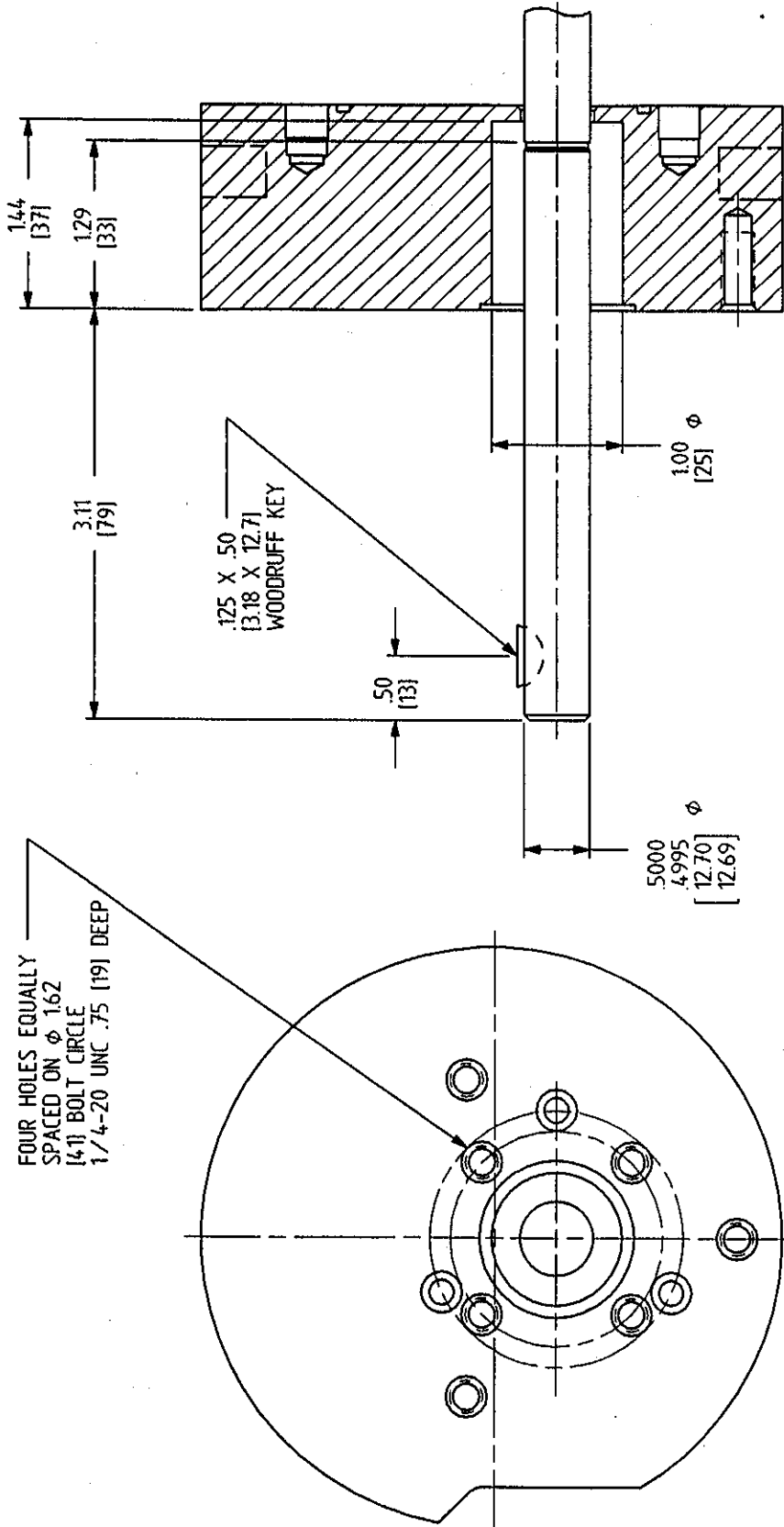

[MM]

FIGURE 3.13.2

# VARIOUS SEALING ARRANGEMENTS

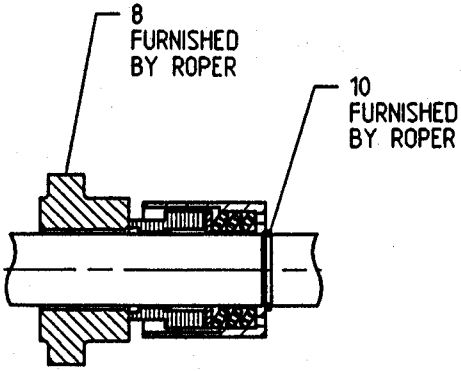

JOHN CRANE® TYPE 8T-1

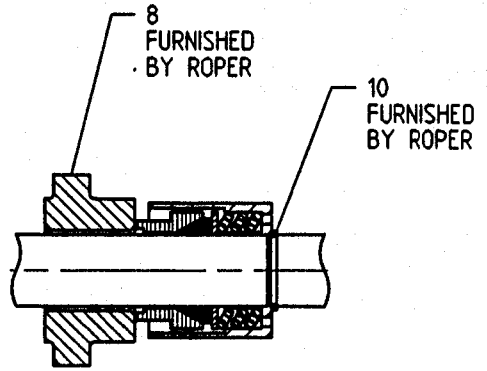

JOHN CRANE® TYPE 9T

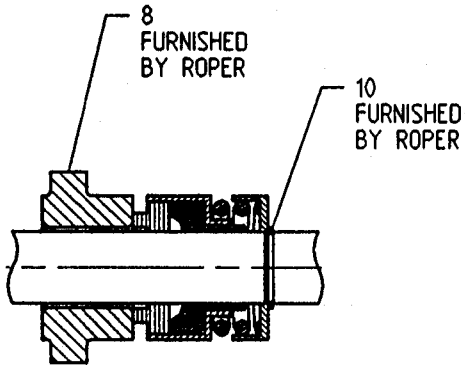

JOHN CRANE® TYPE 21

## SINGLE MECHANICAL SEAL FIGURE 3.13.3

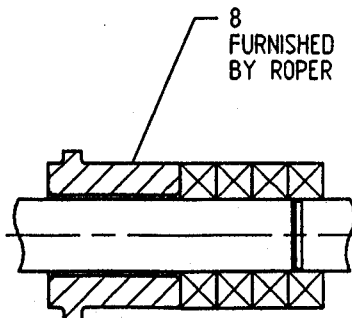

STANDARD PACKED BOX

## PACKED BOX SEAL FIGURE 3.13.4

## 3.14 COMMON MAINTENANCE QUESTIONS

---

**Question:**

At what point do I need to overhaul my pump?

**Answer:**

As with all rotating equipment, your pump will eventually wear to a point where the pump's performance is diminished. The pump's performance is dependent upon the application. For instance, a very worn pump may work at an acceptable level in an application involving a high viscosity (thick) liquid when combined with low discharge pressure. This same pump would most likely be unsatisfactory in a low viscosity, high pressure application. The best answer to the above question is the following: You need to overhaul your pump when you feel that the performance has dropped to an unacceptable level for your application.

If you have set up your own test procedure to check your used pumps, it will be helpful to test at least one new pump of each size to use as a benchmark for setting your own acceptance levels.

**Question:**

What parts will I need to replace to get my pump back to "like-new" condition?

**Answer:**

As a general rule, o-rings, packing, lip seals, and mechanical seals at each servicing regardless of their apparent condition. These parts are usually less expensive than the labor costs and downtime incurred if the pump has to be serviced a second time to stop a leak.

The parts subject to wear should be examined for obvious wear and corrosion. This includes bearings, shafts, gears, cases, and endplates. Measurements should be made and compared to the dimensions shown in Section 3.8. Replace any parts that are worn beyond the limit shown.

What do I look for to determine excessive wear?

- **Gears**

The gears are serviceable if there is no degradation of the teeth or end faces. Check for uniform wear. There should be no burrs or gouges on any of the gear's surfaces.

- **Bearings**

Excessive wear is usually the result of pumping products containing abrasives. If the ends are damaged in the area that the ends of gears rub, they should be replaced. If bearing measurements differ from the dimensions shown in Section 3.8, the bearings should be replaced.

- **Cases**

Excessive case wear is usually the result of worn bearings or shafts allowing gears to contact the case bores.

- **Shafts**

Replace the shaft if it is scored in the packing, seal, or bearing area. Even shafts that appear smooth must be measured and compared to the dimensions shown in Section 3.8.

- **Packing**

Replace packing if it cannot be properly adjusted to control leakage as described in Section 3.13, **SHAFT SEALING**. It is normal and necessary for packing to drip slightly. Never rebuild a pump with used packing.

- **Mechanical Seals**

Scratches on seal faces and deterioration of the elastomers will result in seal leakage. Mechanical seal failures can result in large amounts of liquid leaking from the pump.

**Question:**

Do I need special tools to disassemble and reassemble my pump?

**Answer:**

A list of all tools required can be found in Section 3.2, **TOOL LIST**.

**Question:**

How long can my pump run dry?

**Answer:**

One minute is a practical maximum for running a pump dry. Anything longer could cause the

pump to overheat resulting in possible pump damage or failure.

**Question:**

At what point should I buy a new pump?

**Answer:**

A new pump should be purchased when the old pump cannot be economically repaired.

**Question:**

Are there service centers where I can get my pump repaired?

**Answer:**

Most Roper distributors are able to repair pumps. Consult the factory to find your nearest distributor. Also, Roper Pump Company has a repair department. Any pump repaired at the factory is rebuilt to like-new condition and carries a new pump warranty. Pumps may be returned to the factory by an authorized Roper pump distributor.

## 3.15 INDEX

---

### A

#### Assembly

Instructions for Standard Drive Pump Assembly, 3 - 7 through 3 - 8

Instructions for Mag Drive Pump Assembly, 3 - 8 through 3 - 9

### D

#### Dimensional Data, 3 - 7

Seal Chamber Dimensional, 3 - 14

#### Disassembly

Instructions for Standard Drive Pump Disassembly, 3 - 4 through 3 - 5

Instructions for Mag Drive Pump Disassembly, 3 - 5 through 3 - 7

#### Draining Pump, 3 - 4

#### Drawings

Sectional Drawing, Mechanical Seal Pump, 3 - 10

Sectional Drawing, Mag Drive Pump, 3 - 11

### M

#### Mechanical Seal, 3 - 13

Various Sealing Arrangements, 3 - 15

### P

#### Packing, 3 - 13

#### Parts List, 3 - 12

### R

#### Rotation

Direction of Rotation for Standard Drive Pumps, 3 - 2

Direction of Rotation for Mag Drive Pumps, 3 - 3

### S

#### Safety Signal Words, 3 - 1

### T

#### Tools, 3 - 1





# **ROPER**

## **PUMPS**

Additional copies of the installation and operation manual may be obtained by contacting a Roper distributor or:

**Roper Pump Company**  
**P.O. Box 269**  
**Commerce, Georgia 30529 USA**

**Telephone: (706) 335-5551**  
**TeleFAX: (706) 335-5505**

Your Roper Distributor is:

## TERMS & CONDITIONS AND LIMITED WARRANTY

This agreement (this "Agreement"), consisting of these Terms and Conditions, and the associated Order Acknowledgement is binding upon Roper Pump Company, hereinafter "**SELLER**," and the customer, hereinafter "**BUYER**." By placing an order for a product with the Seller, the Buyer agrees to these Terms and Conditions of sale and acknowledges that the person placing the order has the authority to enter into the Order Acknowledgement on Buyer's behalf.

**LEGAL EFFECT:** Except as expressly otherwise agreed to in writing by an authorized representative of Seller, the following terms and conditions shall apply to and form a part of any Order Acknowledgement. Seller may suspend its performance of any Order Acknowledgement if Buyer defaults in the performance of its duties under the Order Acknowledgement or under any other agreement between the Buyer and Seller.

**ACCEPTANCE:** The sale of goods and services is expressly conditional on Buyer's acceptance of Seller's terms and conditions as stated herein. Provided that Seller's terms and conditions have not been previously accepted by Buyer, Buyer's receipt of goods or services shipped under this Agreement constitutes acceptance of these terms and conditions. No additional, different or conflicting provisions proposed by Buyer are acceptable to Seller and are hereby specifically rejected, Seller being unwilling to sell goods on any terms conflicting with, limiting or modifying the terms hereof. Buyer shall not sell, transfer or otherwise provide any goods to another for resale without the prior, written authorization of Seller. Seller reserves the right to sell and to authorize other entities to sell such goods through all means and channels of distribution and in competition with Buyer. Buyer acknowledges that it has no authority to bind or contract in the name or for the account of Seller, to create any liability against Seller or to exert any direction or control over Seller's personnel.

**CHANGES:** This Agreement and the associated Order Acknowledgement constitutes the entire agreement between Seller and Buyer with respect to the subject matter thereof, and supersedes all prior oral or written agreements. This Agreement and the associated Order Acknowledgement may not be amended or modified, except by a further written agreement signed by an authorized representative of Seller. Seller reserves the right to make reasonable changes to an Order Acknowledgement, including changes as to packaging, testing, specifications, designs and delivery schedules. The terms and conditions of any purchase order or other instrument issued by Buyer or its agent in connection with this Agreement and the associated Order Acknowledgement or any goods sold thereunder that is in addition to or inconsistent with the terms and conditions of this Agreement or the associated Order Acknowledgement are null and void and shall not be binding on Seller. Buyer's changes made after formation of this Agreement that affect the schedule or requirements for services or otherwise affect the scope of this Agreement shall be submitted in writing by Buyer and shall become binding only if approved in writing by Seller's cognizant representative. All charges and delays resulting from such changes shall be solely determined by Seller and shall be binding upon Buyer.

**TERMINATION, SUSPENSION, AND CANCELED ORDERS:** Provided that Seller receives adequate written notice from Buyer, Buyer may terminate or suspend performance at Buyer's convenience subject to all reasonable charges, which charges shall be solely determined by Seller. Buyer cannot cancel or alter Orders without the Seller's written consent. If Seller grants such consent, Buyer will reimburse Seller for all of Seller's losses and expense caused by such cancellation or alteration, including without limitation all of Seller's additional costs caused by changes in design or specifications, or by product revisions, and all incidental and consequential damages incurred by Seller as a result of such cancellation or alteration. No goods may be returned to Seller except with Seller's written consent. Title in a returned good will pass when Seller takes possession of the returned goods.

**CREDIT:** The amount of credit offered by Seller to Buyer is contingent upon Seller's opinion of Buyer's capacity, ability, and willingness to promptly pay for goods and services received under the terms of this Agreement. Provided that, in Seller's opinion, there is a material adverse change in Buyer's financial condition and/or Buyer has not, within the agreed time, fully paid for goods and services previously supplied under this and/or another Agreement(s) with Seller, Seller reserves the right to revoke Buyer's credit and/or suspend performance on this and/or other orders for goods and services.

**PAYMENTS:** Standard terms for customers who qualify for credit net 30. A monthly service charge of 1.5% may be charged on amounts owed by Buyer to Seller that have not been paid within by the due date, subject to the maximum amount permitted by law.

**TAXES.** Buyer assumes exclusive liability for any and all taxes, tariffs, fees, duties, withholdings or like charges, whether domestic or foreign, now imposed or hereafter becoming effective ("Taxes") related to the goods and its purchases from Seller, including without limitation, federal, provincial, state and local taxes, value-added taxes, goods and services taxes, stamp, documentary, excise or property taxes, duties and other governmental charges.

**TITLE AND LIEN RIGHTS:** The equipment will remain personal property, regardless of how it is installed or affixed to any realty or structure. After delivery to Buyer, Seller will have all such rights, including security interests and liens, in the equipment as lawfully may be conferred upon Seller by contract under any applicable provision of law. Buyer agrees to cooperate fully with Seller in the filing of any financing statements, including Uniform Commercial Code (UCC) filings or other documents necessary to perfect such interests and liens. If Buyer defaults in its obligations under the Order Acknowledgement before the price (including any notes given therefore) of the equipment has been fully paid in cash, Seller may take any and all actions permitted by law to protect its interests including, where permissible, repossession of such equipment.

**SHIPMENTS:** All sales are Ex-Works Factory (as such term is defined by the International Chamber of Commerce as of the date hereof). Shipping contracts made by Seller shall be to Buyer's account. All claims for loss or damage after risk of loss has passed to Buyer shall be filed by Buyer with the carrier. Buyer shall be liable to Seller for the full price of the goods, irrespective of loss or damage in transit. Seller shall not be required to provide freight cost receipts to Buyer at the time of invoice. Buyer shall bear all risk and expense for delivery of goods, including without limitation, shipping, loading, unloading, storage, freight, and insurance. Goods may be shipped to Buyer in whole or in part. Title to goods shall pass to Buyer when delivered to the carrier or the Buyer, whichever occurs first, even if the goods are shipped freight prepaid. Among other things, a signed delivery receipt or bill of lading will constitute proof of delivery. The choice of carrier is made solely at the discretion of Seller, and Seller makes no representation as to the acceptability of a particular carrier. Except when Seller expressly agrees in writing, Seller does not guarantee shipment or delivery by a certain date or time, although Seller will strive to deliver goods by the date that it may communicate to Buyer. Seller shall not be liable to Buyer, or any other person, for any loss or damage of any kind which results from delay in shipment, delivery, or failure to give notice of delay, whether or not such delay was caused by Seller or otherwise. Seller reserves the right to backorder any goods and to ship from backorder in such order as Seller determines.

**LIMITED WARRANTY:** Seller warrants, to its original Buyer, that goods manufactured by Seller are free from defects in material and workmanship for 12 months from date of shipment (except for specified products with warranties that supercede this limited warranty. Please consult factory for these products). The Buyer hereby acknowledges and agrees, though free from defects in material and workmanship at the time of shipment, that the useful life of goods manufactured by Seller will vary depending upon the Buyer's frequency of use, application, and other factors, with regard to such goods. In that respect, notwithstanding any other provision to the contrary in the Agreement, these Terms and Conditions, or the Order Acknowledgement, the Seller specifically does not warrant the useful life of any product. If a failure to conform to specifications or a defect in materials or workmanship is discovered within this period, Seller must promptly be notified in writing within thirty (30) days, which notification, in any event must be received no later than 12 months from the date of shipment. Within a reasonable time after such notification, Seller will correct any failure to conform to specifications or any defect in materials or workmanship, or in lieu of

such repair, and at its sole option, shall replace the equipment. THE ABOVE ARE THE BUYER'S EXCLUSIVE REMEDIES FOR BREACH OF WARRANTY. Seller does not warrant: (a) defects caused by failure to provide suitable installation environment for the product, (b) damage caused by use of the product for purposes other than those for which it was purchased, (c) damage caused by disasters such as fire, flood, wind, and lightning, (d) damage caused by unauthorized attachments, or modification, (e) any other abuse or misuse by the Buyer, including improper installation; or (f) goods which have been damaged or altered by Buyer or its customers.

Each good sold by Seller to Buyer shall be deemed to be without defect and in conformity with its specifications and the terms of this Agreement and the associated Order Acknowledgement even though reasonable variances may exist. As a result, Seller cannot and does not guarantee that goods sold hereunder, whether in whole or in part, will exactly match in specification or otherwise, and Buyer acknowledges that reasonable variance is permissible. Additionally, Seller shall have no liability if a good does not conform to any applicable state, county or local ordinance, as the conformity of a good to each state, county and local ordinance is the sole responsibility of the Buyer. Seller reserves the right to change its goods and the components of its goods without prior notice to Buyer, although in circumstances where an order from Buyer has been accepted by Seller, Seller will use commercially reasonable efforts to ensure that such change will not affect performance of the good in a materially adverse manner.

**EXCEPT AS SET FORTH ABOVE AND TO THE MAXIMUM EXTENT PERMITTED BY LAW, SELLER MAKES NO OTHER WARRANTIES FOR A PRODUCT OR UNDER THIS AGREEMENT OR ANY ORDER ACKNOWLEDGEMENT AND HEREBY DISCLAIMS ALL OTHER WARRANTIES, EXPRESS OR IMPLIED, INCLUDING BUT NOT LIMITED TO THE WARRANTY OF FITNESS FOR A PARTICULAR PURPOSE OR USE, AND INCLUDING THE WARRANTY OF MERCHANTABILITY. IN NO CASE SHALL SELLER BE LIABLE FOR ANY SPECIAL, INCIDENTAL, OR CONSEQUENTIAL DAMAGES BASED UPON ANY LEGAL THEORY, INCLUDING BUT NOT LIMITED TO LOSS OF PROFITS, LOSS OF SAVINGS OR REVENUE, LOSS OF USE OF THE PRODUCT OR ANY ASSOCIATED EQUIPMENT, COST OF CAPITAL, COST OF ANY SUBSTITUTE EQUIPMENT, FACILITIES OR SERVICES, DOWNTIME, THE CLAIMS OF THIRD PARTIES INCLUDING CUSTOMERS, INJURY TO PROPERTY AND, UNLESS PRECLUDED UNDER APPLICABLE STATE LAW, BODILY AND PERSONAL INJURY.**

**INDEMNITY; LIABILITY LIMITATION:** Buyer hereby agrees to indemnify, reimburse in full, defend and hold harmless Seller, its subsidiaries, affiliates, officers, directors, personnel and agents from and against any and all liability, claims, suits, actions, losses, costs or expenses including (without limitation) reasonable attorneys' fees relating to or arising out of any claim or demand (a) for any Taxes or related penalties and interest, (b) due to Buyer's breach of the Order Acknowledgement; (c) that Buyer's customers or a third party may make against Seller based upon or arising from damage due to the acts and/or omissions of Buyer or due to the installation of the goods; (d) for infringement or misappropriation of a third party's intellectual property rights based upon Seller's incorporation of any designs, formulas or specifications in any goods where such designs, formulas or specifications have been specifically ordered or requested by Buyer. To the maximum extent allowable under applicable law and excluding those liabilities that by law Seller cannot limit or disclaim, (i) Seller's aggregate liability arising from or relating to this Order Acknowledgement or goods, regardless of the cause of action asserted, is limited to the amount paid by Buyer to Seller for the applicable goods and (ii) Seller shall not be liable for any special, incidental, consequential, indirect, or punitive damages, including without limitation, lost revenues, loss of use of the goods, loss resulting from improper storage, processing, padding/cushion, delay in delivery or shipment or errors in shipment or labeling, loss of data, or the cost of any substitute goods or related equipment, even if Seller has been advised of the possibility of such damages.

**EXPORT RESTRICTIONS:** Buyer shall not export or re-export goods in violation of any applicable laws or regulations of the United States or the country in which Buyer obtained them.

**CONFIDENTIAL INFORMATION.** During the term of this Agreement and the associated Order Acknowledgement and for the longer of (a) three (3) years following its termination and (b) for such Confidential Information of Seller that is a Trade Secret of Seller as defined by applicable law, for the life of such Seller Trade Secret, Buyer agrees to receive and hold Confidential Information of Seller in trust and in strictest confidence and shall not use, reproduce, distribute, disclose or otherwise disseminate any Confidential Information except as necessary to perform its obligations hereunder. Disclosures of the Confidential Information may be made only to Buyer's employees and agents who have a specific need to know and are subject to confidentiality restrictions at least as restrictive as those contained herein. "Confidential Information" means confidential information relating to the business, products and services of Seller which is or has been disclosed to Buyer, and which has value to Seller and is not generally known to Seller's competitors, including (without limitation), information regarding the specifications provided to Buyer by Seller and Seller's product plans, designs, costs, prices, finances, marketing plans, business opportunities, personnel, R&D activities and know-how.

**CONTROLLING LAW:** This Agreement and the associated Order Acknowledgement entered into hereunder shall be governed and construed in accordance with the laws of the State of Georgia and of the United States of America without reference to any conflicts of law principles; the parties submit themselves to the jurisdiction of the federal and state courts located in Jackson County, Georgia, which shall have exclusive jurisdiction of any disputes arising hereunder, and the parties waive any objection to venue therein. The United Nations Convention on Contracts for the International Sale of Goods, the Uniform Law on the Formation of Contracts for the International Sale of Goods, and any applicable international discovery and service of process conventions shall not be applicable. In the event legal action is undertaken by Seller to collect any amounts due to Seller by Buyer hereunder and if Seller prevails in such action, then Buyer shall reimburse Seller for its reasonable attorney fees and costs incurred in conjunction with such action, which amount shall not exceed the maximum amount allowed by law of the forum in which such action is brought.

**ASSIGNMENT:** Neither this Agreement nor any associated Order Acknowledgement may be assigned by the Buyer, or its contents publicized by the Buyer, without the written consent of Seller. Seller shall have the right to assign, transfer or sublicense all or any part of this Agreement or any associated Order Acknowledgement to another at any time and without the consent of Buyer.

**MISCELLANEOUS:** The various provisions of this Agreement and any associated Order Acknowledgement are severable, and any determination of invalidity or unenforceability of any one provision hereof shall no bearing on the continuing force and effect of the remaining provisions hereof. This Agreement and any associated Order Acknowledgement and the terms and conditions contained herein constitute the entire understanding of the parties with respect to the purchase and sale of the goods, and any prior agreements, with respect thereto, whether written or oral, are superseded hereby. This Agreement and any associated Order Acknowledgement shall be binding on the parties and their respective successors and any permitted assigns.

**ELECTRONIC DATA INTERCHANGE.** The parties may execute a Order Acknowledgement by transmitting and receiving the data contained in the Order Acknowledgement electronically rather than in paper form. To provide the legal validity and enforceability of such Order Acknowledgement, the parties further agree that the data transmitted herein will be considered "in writing" and to have been "signed." The parties agree not to contest the validity or enforceability of a Order Acknowledgement because of the electronic origination, transmission, storage or handling of such Order Acknowledgement. Any computer printout of the data contained in the Order Acknowledgement will be considered an "original" when maintained in the ordinary course of business and will be admissible as between the parties to the same extent and under the same conditions as other business records maintained in documentary form. The parties agree to properly use those security procedures which are reasonably sufficient to ensure that a transmission of the data contained in a Order Acknowledgement is authorized and to protect its business records and data from improper sources.