

LECTRA/SAN[®] MC[™]

Installation and Maintenance Instructions

THE FOLLOWING ARE CAUTIONARY STATEMENTS THAT MUST BE READ AND FOLLOWED DURING BOTH INSTALLATION AND OPERATION

WARNING: *Raritan Engineering Company, Inc. recommends that a qualified person or electrician install this product. Equipment damage, injury to personnel or death could result from improper installation. Raritan Engineering Company, Inc. accepts no responsibility or liability for damage to equipment, or injury or death to personnel that may result from Improper installation, trouble shooting, repairs to or operation of this product.*

WARNING: HAZARD OF SHOCK AND FIRE - Always use recommended fuse/circuit breaker and wire size.



WARNING: HAZARD OF FLOODING - Always shut off seacocks before leaving boat unattended.



Double clamp all hose fittings below the waterline, check hose clamps frequently for integrity.

WARNING: *The Lectra/San MC operates on an Electrochemical principle. Introduction of any substance other than salt water, human waste, Raritan Concentrate, Raritan C.P. or toilet tissue may cause heat build up and extensive damage. If any other substance is introduced by accident, the Lectra/SanMC must not be turned on until entire system is flushed out with water.*

Lectra/San MC with control

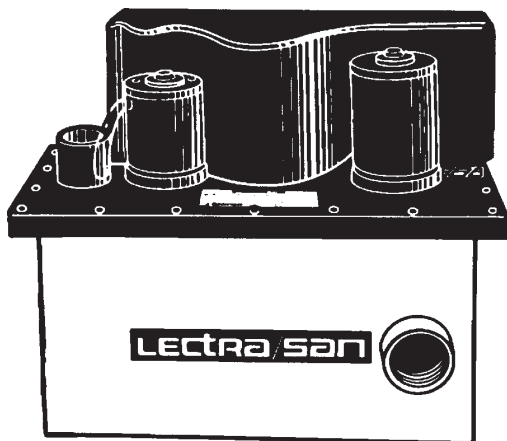

optional salt feed systems

4 gallon tank:
1 with pump
1 without pump

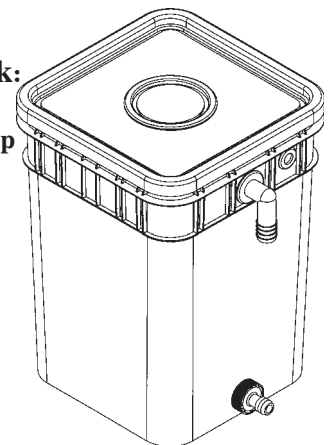
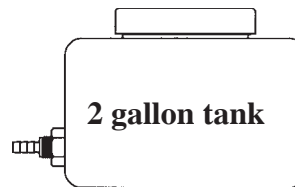

The Lectra/San[®] MC (LST/MC[™]) is a U. S. Coast Guard Certified Type I Marine Sanitation Device for use on inspected and uninspected vessels 65 feet and under. It must be operated within areas that are not declared a Federal No Discharge Zone (NDZ) by the U.S. Environmental Protection Agency (EPA). This is applicable for all U.S. territorial waters inside the three mile limit. Other countries - check with local authorities.

LST/MC is designed for recreational use and accommodates most marine toilets* it can be used with one or, in some cases, two toilets. The Lectra/San MC is available in 12, 24 or 32 V DC.

The system consists of a Control Indicator Panel and Treatment Tank. A salt feed system **must** be utilized if operating in fresh or brackish water.

* for use with the VacuFlush[®] marine toilet manufactured by Sealand Technology, Inc., (See Application note L286)

VacuFlush[®] is a registered trademark of Sealand Technology, Inc.

Lectra/San[®] is a trademark of Exceltec.

LST/MC[™] is a trademark of Raritan Engineering Co., Inc.

(depends on installation chosen)

Single Button operation -

Both toilet and Lectra/SanMC are operated by one of the following options:

Option #1:

Control Indicator Pad (LST/MC Touch Pad)

"Push to Flush" button activates both the toilet and treatment cycle. Button may be pressed as often as necessary to flush toilet until Normal Treatment light (green) begins to blink 35 seconds after activation.

Note: Toilet flush time is factory preset for 8-12 seconds and is adjustable, see diagram adjusting flush time under installation/wiring.

Option #2:

Toilet Push Button -

Flushing toilet will activate treatment cycle. Flush toilet as often as necessary until Normal Treatment light (green) begins to blink.

Independent Button operation -

"Push to Flush" button must be pressed before toilet is flushed. Flush toilet as often as necessary until Normal Treatment light begins to blink 35 seconds after activation.

To Stop Treatment Cycle -

"R" button stops the treatment cycle should a foreign object accidentally enter the treatment system. If wired per option #1 the "R" will also stop the toilet from flushing.

Notes:

- 1) **Total flush volume must not exceed 1.5 gallons (5.7 liters) per cycle.**
- 2) **Operating with yellow light for extended periods will damage electrode and void warranty**

How it works -

Each time toilet is flushed an equal amount of previously teated waste is discharged. The Lectra/San does not pump waste out, the flushing action of the toilet moves the waste through the Lectra/San.

The first chamber macerates to reduce particle size. The second chamber mixes to ensure uniform treatment of contents. The electrode plates, when electricity is applied, generates bactericide in both chambers.

When activated both motors come on and run for the entire cycle. The user then has up to 35 seconds to flush toilet. After 35 seconds the electrode is energized to begin the treatment process. The treatment process lasts for about 2 minutes.

Note: If the green light is not flashing during treatment, the cycle has been automatically extended to ensure proper treatment. The unit MUST not be operated in extended cycle for long periods as damage to electrodes will occur. Immediately attempt to determine and fix an amber or red light condition.

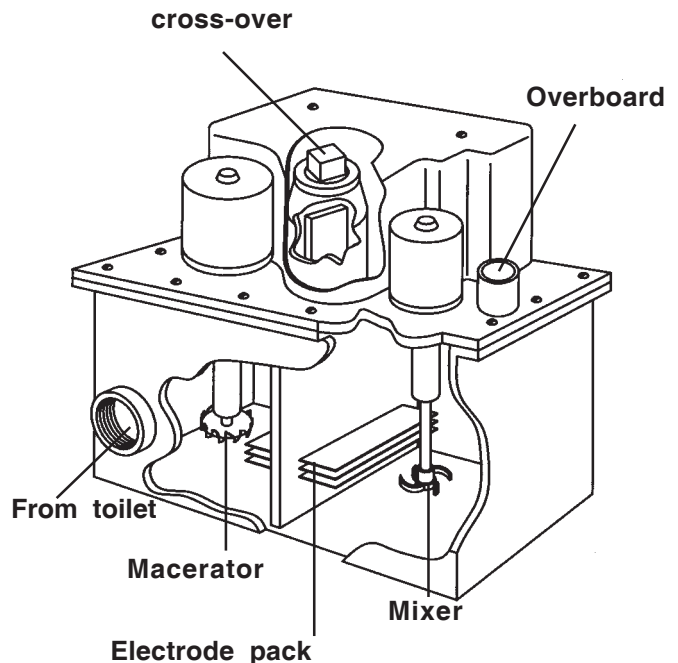
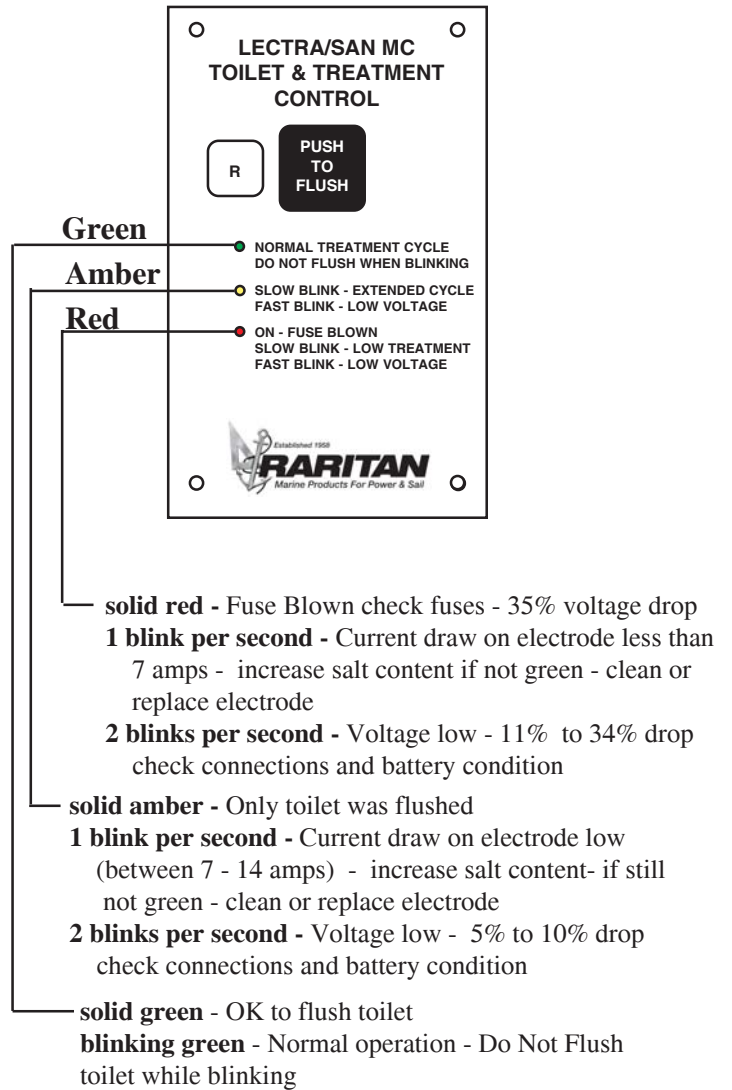

Cleaning Instructions

IMPORTANT: Do not use bowl cleaners that contain ammonia, ethyl acetate, phosphoric acid or concentrated chlorine bleach. These will cause damage to treatment system. C.P. is the only toilet bowl cleaner recommended by Raritan.

Using Raritan's C.P. Cleans Potties (part #1PCP22), a bio-enzymatic toilet bowl cleaner, will keep the bowl clean and fresh smelling and won't damage the treatment system.

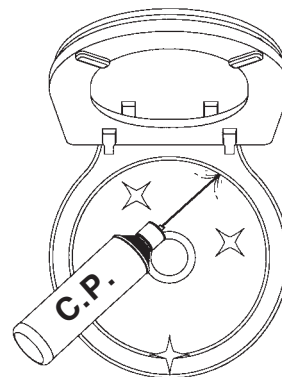

Recommended Visual Inspection

- √ For leaks at hose connections
- √ Hose clamps
- √ Condition of hoses
- √ Seacocks
- √ Condition of wires and connections

Treatment/Electrode cleaning

Note: Cleaning is recommended every two years with recreational use or if amber light is always on during treatment cycle.

1. Activate the LST/MC and flush toilet several times, allowing all waste to be treated.
2. Turn off water supply and flush toilet as dry as possible.

NOTE: Check toilet manufacturer's instructions to ensure no damage is done to any components.

3. Turn off power and disconnect wires to LST/MC.

WARNING: LST/MC must not be activated while muriatic acid solution is in the system.

4. In plastic bucket combine 1.5 pints (.852 liters) of muriatic acid with 3 gallons (13.635 liters) of fresh water.

WARNING: Add acid to the water, DO NOT place acid in the container first.

5. Carefully pour solution into the toilet and flush until bowl is as dry as possible.
6. Pour one gallon (3.8 liters) of additional fresh water into bowl to dilute any acid remaining.
7. Allow to stand for a **minimum** of 45 minutes.
8. Turn on water supply and flush a minimum of 10 gallons (38.0 liters) of water to dilute and discharge muriatic acid solution.
9. Reconnect wires and restore power to LST/MC.

Storage

Short Term - If system will not be used for a week flush toilet and run treatment cycle several times.

Long Term - If system will not be used for several weeks flush toilet and run treatment cycle several times. Then flush freshwater into system. Prior to use - flush toilet several times to refill treatment tank with ocean salinity salt water.

IMPORTANT

- **Improper winter lay up is a major cause of failure.**
- **Flush toilet and activate Lectra/San several times .**

Steps

1. Activate the LST/MC and flush toilet several times, allowing all waste to be treated.
2. Turn off water supply and flush toilet as dry as possible.

NOTE: Check toilet manufacturer's instructions to ensure no damage is done to any components.

3. Turn off power and disconnect wires to LST/MC.
4. Close seacocks.
5. Remove control cover and slowly open cross-over cap.

Caution: Open cap slowly as unit may be under pressure.

5. Using a pump, remove water from both sides of the treatment tank through crossover cap.
6. Disconnect and drain hoses.

Recommissioning & Start-Up

1. Reconnect hoses and open seacocks.
2. Reconnect wires and turn power on.

NOTE: LST/MC treatment tank must be full before activating a cycle.

3. Flush toilet using one of the following methods to fill the treatment tank with salt water.
 - Single button operation - Press "Push to Flush" while holding down the "R" button, correct operation is indicated by center Amber light on.
 - Separate operation - flush toilet allowing three gallons of water to pass into LST/MC.
 - Toilet operates LST/MC - you must disconnect power from LST/MC while flushing to allow three gallons of water to pass into LST/MC.

NOTE: In fresh and brackish water operation slat content of treatment tank must be ocean water salinity prior to using unit for treatment. Ocean water salinity is 4% or approximately four ounces of salt to one gallon of water.

4. Inspect all connections for leaks.
5. System is ready for use.

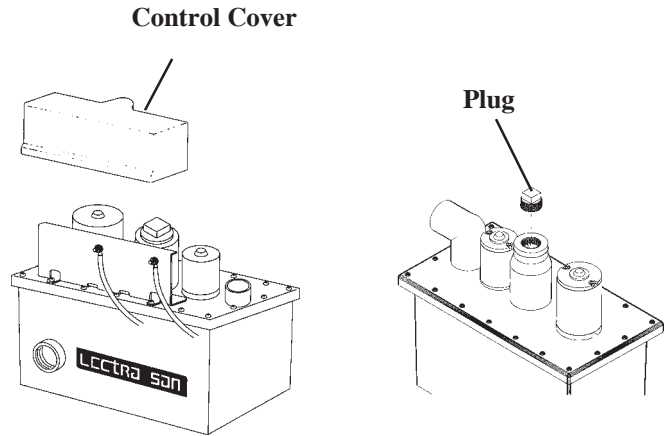

U.S.C.G. Type I MSD Certification #159.015/0107/1

Maximum Roll/Pitch Angle: 30°

Maximum Temperature Exposure: 120° F (49° C)

Maximum Total Flush Volume: 1.5 gallons/flush (5.7 liters/flush)

Designed for recreational use - heavier use may require more frequent replacement of electrode pack.

NOTES: for Wiring

1.	Distances are from source to unit and back to source.
2.	Recommended conductor wire minimum AWG (mm ²) for 3% voltage drop.
3.	Recommended conductor sizes are based on 105°C rated insulation. Refer to ABYC Standards for other insulation ratings.

Recommended Wire and Fuse/Circuit Breaker Size

Units Voltage	Circuit Breaker/fuse size (amps)	Amp. draw @ nominal voltage	10 feet	15 feet	20 feet	25 feet	30 feet	40 feet	50 feet
12 VDC	60	50	6 AWG	6 AWG	4 AWG	4 AWG	2 AWG	2 AWG	1 AWG
24 VDC	50	42	10 AWG	8 AWG	6 AWG	6 AWG	6 AWG	4 AWG	4 AWG
32 VDC	50	35	12 AWG	10 AWG	10 AWG	8 AWG	8 AWG	6 AWG	6 AWG

FUSE SPECIFICATIONS

	12 VDC Fuse type Maximum amperage part number	24 VDC Fuse type Maximum amperage part number	32 VDC Fuse type Maximum amperage part number
FUSE A Mixer Motor	MDL 6 1/4 5 amp draw 32-218	MDL 6 1/4 4 amp draw 32-218	MDL 5 4 amp draw 34-218
FUSE B Electrode Pack	MDL 35 25 amp draw 32-219	MDL 30 22 amp draw 32-220	MDL 30 22 amp draw 32-220
FUSE C Macerator Motor	MDL 30 20 amp draw 32-220	MDL 25 16 amp draw 33-220	MDL 20 9 amp draw 34-220

CONVERSIONS

Wire - AWG to mm²

AWG	16	14	12	10	8	6	4	2
mm ²	1.5	2.5	4.0	6.0	10.0	16.0	25.0	35.0

Feet to Meters

Feet	10	15	20	25	30	40	50
Meter	3.1	4.6	6.1	7.6	9.2	12.2	15.2

Salt Feed System Options

IMPORTANT:

A salt feed tank is required when operating system with fresh or brackish water. Operating in low salt conditions without the addition of salt will shorten life expectancy of the electrode plate and will void warranty.

The following are available to purchase:

NOT FOR USE WITH TOILETS THAT USE PRESSURIZED FRESH WATER:

Two Gallon (7.6 liters) Salt Feed Tank

(Part #31-3001) - Tank must be filled with a saturated salt solution which is dispensed via a T-check valve into incoming water. One system per toilet. For use in slightly brackish water, if used in fresh water tank will only last for approximately 15 flushes of the toilet.

Four Gallon (15.2 liters) Salt Feed Tank

(Part #31-3002) - Tank must be connected to pressurized fresh water and filled with solar salt. The saturated salt solution is dispensed via a T-check into incoming water. One system per toilet. Requires manual adjustment as water salinity changes.

FOR USE WITH ANY LECTRA/SAN M/C SYSTEM WHERE SALT MAY BE NEEDED AND IS NECESSARY FOR ALL TOILETS THAT USE ON-BOARD PRESSURIZED FRESH WATER:

Four Gallon (15.2 liters) Salt Feed Tank with Pump

(Part #32-3003 12 Volt and #33-3003 24 Volt) The tank must be connected to pressurized fresh water and filled with solar salt. The pump is controlled by the MC Circuit Board. This system can only be used with the LST/MC. One system per LST/MC. This is the most accurate system to use as the amount of saturated salt solution is controlled by the actual operating conditions of the Lectra/San MC.

Parts Included with the LST/MC

- 1 1/2" hose adapters (2)
- 1 1/2" NPT Intake Plug
- 90° 1 1/2" slip PVC fitting
- control indicator panel with cable

Optional Parts available for purchase:

- Dual Control
- Salt Feed Systems
- Manual head sensor for automatic activation

Parts Required (not included)

- Teflon tape or nonpermanent thread sealing compound
- PVC Cement
- 1 1/2" (3.8 mm) I.D. sanitation hose (raritan part # SH)
- Hose clamps
- 1" (2.54 cm) x 1" (2.54 cm) wood strips and fasteners to secure to floor (wooden frame)
- 3/4" (1.9 cm) strapping
- Electrical connections, wire and fuse or circuit breaker

NOTE:

Discharge of raw, untreated sewage is prohibited in all U.S. waters inside the three mile limit except in the Gulf of Mexico where the limit is nine miles. "Y" valves, if installed, must direct toilet discharge to a U.S.C.G. approved treatment system or holding tank and must be secured in that position while inside the three-mile limit.

The EPA standards state that in freshwater lakes, freshwater reservoirs or other freshwater impoundments whose inlets or outlets are such to prevent the ingress or egress by vessel traffic subject to this regulation, or in rivers not capable of navigation by interstate vessel traffic subject to this regulation, marine sanitation devices certified by the U.S. Coast Guard installed on all vessels shall be designed and operated to prevent the overboard discharge of sewage, treated or untreated, or any waste derived from sewage. The EPA standards further state that this shall not be construed to prohibit the carriage of Coast Guard-certified flow-through treatment devices which have been secured so as to prevent such discharges. They also state that waters where a Coast Guard-certified marine sanitation device permitting discharge is allowed including coastal water estuaries, the Great Lakes and interconnected waterways, freshwater lakes and impoundments accessible through locks, and other flowing waters that are navigable interstate by vessels subject to this regulation (40 CFR 140.3)

MOUNTING

Treatment Tank

WARNING: DO NOT locate in an area where ambient temperature exceeds 120° F (49° C).

Note: Control board is located under control cover and should be accessible after installation

1. Locate top of treatment tank at or below discharge of toilet and within six feet (1.5 m).

Note: If mounting treatment tank higher than discharge. Contact Raritan

2. Make and secure mounting frame to flat surface.
3. Secure tank to frame using 3/4" (1.9 cm) mounting straps.

Note: Placing a 3/8" (.9 cm) rubber pad under tank will help to reduce vibration and noise.

Control Indicator Panel

Note: Cable supplied is 14 feet (4.25 m) if required, a 25 foot (7.62 m) cable is available.

1. Locate in head compartment where indicator lights will be visible.
2. Using template provided, mark the cutout for the panel.
3. Route cable between Control Indicator Panel and LST/MC Treatment Unit.
4. Plug cable into back of indicator panel.
5. Mount panel using 4 screws. Apply a bead of nonpermanent sealant around rear edges of panel if located in shower area.

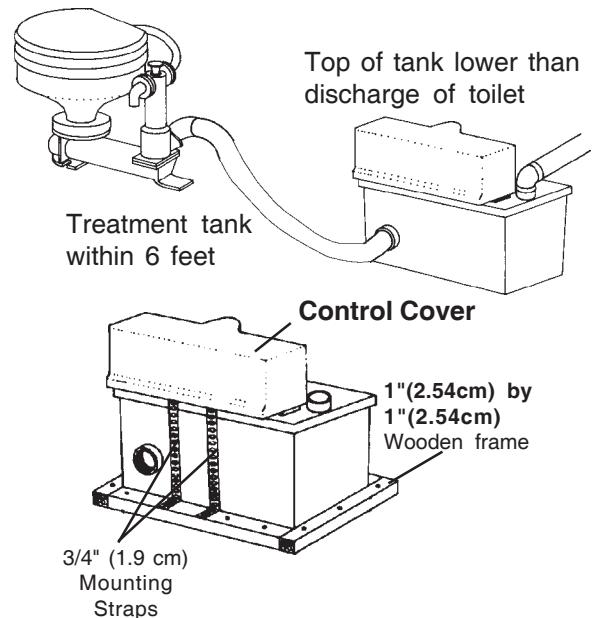

PLUMBING

WARNING:

- All installations made below the waterline **MUST** be protected by installing vented loops in proper location
- Always double clamp fittings below waterline
- Do Not use metal fittings

NOTE: Use teflon tape or nonpermanent thread sealing compound on threaded PVC fittings and connections. Avoid low areas in hose that would allow untreated waste to collect.

1. Connect discharge of toilet to one inlet port.
2. Insert plug or second toilet discharge into other inlet port.
3. Determine position and glue discharge elbow to top of tank using PVC cement.
4. Connect discharge hose from elbow to thru hull fitting.

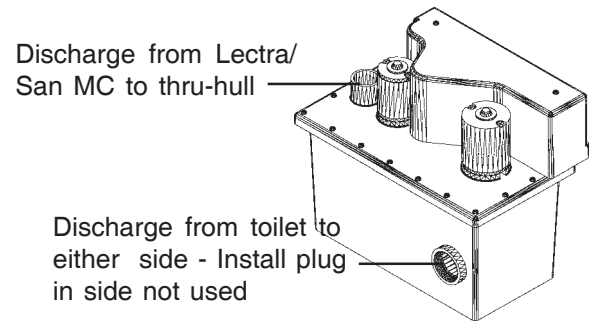

WIRING

WARNING: Hazard of Shock and Fire

- Always use proper wire, wire connectors and fuse/circuit breaker. See Specification Chart.
- Secure wire properly.
- Do not connect other appliances to Lectra/San circuit.
- Make sure power is off before proceeding.
- Improper wiring can damage the Circuit Board and void warranty.

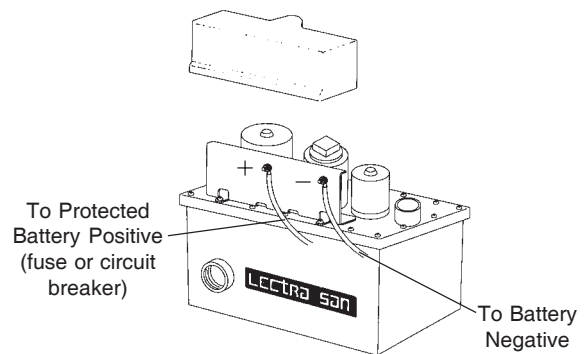

Treatment Unit

1. Determine proper wire size from wire chart on specifications page.
2. Run supply wire from source to Positive (POS) and Negative (NEG) terminals on Treatment tank.
3. Fuse or circuit breaker must be installed between source and LST/MC on positive wire.

NOTE: Future access to control assembly is imperative. If unit is installed in an area where access will be difficult contact Raritan for instructions on mounting the control module remotely.

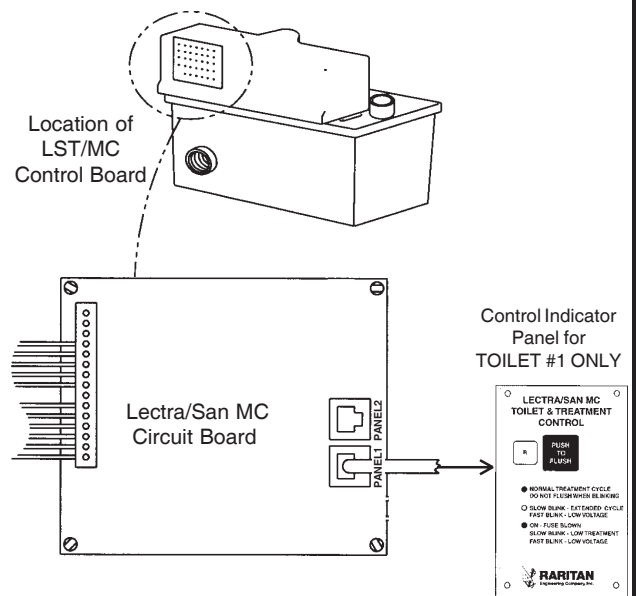

Control Indicator Panel

1. Connect cable from Control Indicator Panel to Circuit Board panel 1 jack.
2. Secure cable strain relief.
3. Follow same procedure to panel 2 jack if second toilet connected to LST/MC.

Single Button operation -

Both toilet and Lectra/San are operated by one of the following options:

NOTES:

- Use only a solenoid/relay with an isolated coil Raritan part number CDS* (*specify voltage)
- Connect only the solenoid/relay (CDS) coil to toilet 1 or 2 output on the circuit board. DO NOT connect toilet negative and positive directly to outputs.
- Do Not connect switches or any other components to the Toilet 1 or 2 outputs.
- Do not connect any additional wires to CDS other than wiring in diagrams shown in this guide.

Option #1:

Control Indicator Pad (LST/MC Touch Pad)

"Push to Flush" button activates both the toilet and treatment cycle.

Note: Toilet flush time is factory preset for approximately 8-12 seconds and is adjustable.

1. Determine proper wire size from toilet manufacturer.
2. Connect wire from lug not marked "BAT" on the CDS to toilet positive.
3. From top posts of CDS connect positive and negative to toilet 1 or 2 outputs on circuit board utilizing 3 amp fuse in positive line.
4. Connect wire from positive source to Raritan CDS (solenoid/relay) post marked "BAT" utilizing proper fuse in positive line.
5. When Push to flush button is pressed both toilet and Lectra/San will activate. Toilet flush time is controlled by Control Indicator Panel and can be adjusted - factory preset is for approximately 10 seconds.

NOTE: If installation is done with a Raritan A5 or A6 Atlantes the flush time adjustment on the back of the control indicator panel must be set to the minimum. See Atlantes manual to adjust flush time.

Option #2:

Toilet Push Button -

Flushing toilet will activate treatment cycle.

Toilet Push Button

1. Determine proper wire size from toilet manufacturer.
2. Connect wire from lug not marked "BAT" on the CDS to toilet positive.
3. Connect wire from top post of CDS to one of the ext. trig. (external trigger) outputs.
4. Connect wire from positive source to Raritan CDS (solenoid/relay) post marked "BAT" utilizing proper fuse in positive line.
5. When Toilet Push Button is pressed both toilet and Lectra/San will activate.

Adjusting flush time

CONTROL INDICATOR PANEL(REAR VIEW)

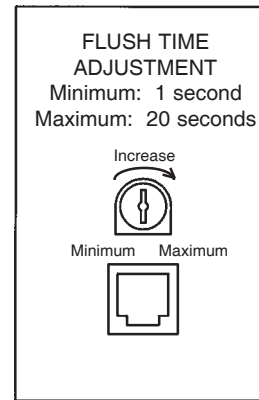

Control Indicator Panel activation of Toilet and Lectra/San

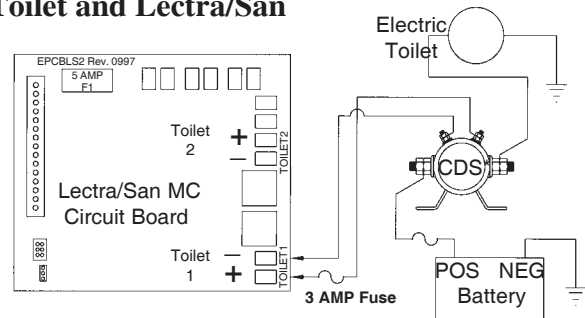

Toilet Push Button activation of Toilet and Lectra/San

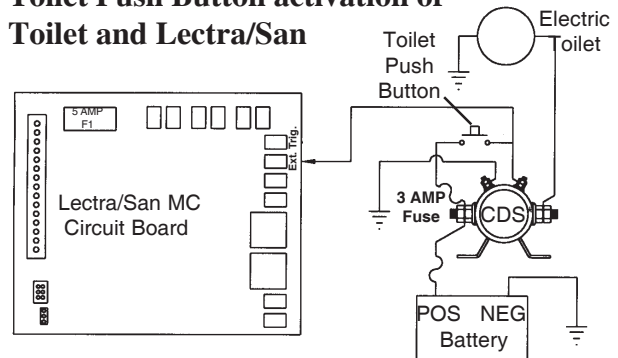

When "Push to Flush" doesn't activate system

- **No Power to unit**
Check circuit breaker or main fuse to unit
Check wiring to unit
- **Open or loose connection**
Check and clean wiring connections
- **Circuit board fuse**
Check circuit board fuse
- **Damage to circuit board**
Check for burned foils, replace if necessary
- **Inoperative control indicator panel**
Check, replace if necessary
- **Damage to control indicator panel cable**
Check, replace if necessary

Red light on, not blinking

- **Fuse blown**
Check fuse A, B and C on control module
- **Damage to circuit board**
Check, replace if necessary
- **Inoperative solenoid**
Replace solenoid
- **Damaged control module wire harness**
Replace wire harness
- **Bad fuse block or weak fuse holders**
Replace fuse block

Amber or Red light slow blink-1 blink per second

- **Low salt**
Add salt to system, install salt feed system if operating in fresh or brackish water
- **Build-up on electrode pack**
Clean following instructions in Maintenance
- **Non-functioning electrode pack**
Check, replace if necessary

Amber or Red light fast blink-2 blinks per second

- **Low voltage**
Discharged or bad battery, charge or replace undersized wiring, check specification chart
- **Drop in line voltage**
Check voltage between B fuse and negative post
- **Other equipment operating on same circuit as LST/MC**
Isolate LST/MC
- **Open or loose connections**
Check and clean wire connections

Sewage Odor

- **Odor permeating through hose or connections**
Rub damp rag on hose, if odor transfers to rag hose needs to be replaced with high quality sanitation hose Raritan part # SH
- **Treatment unit is leaking**
Follow discharge hose from toilet to tank, lift blue cover (31-460) and check area around motors too
- **Electrode not functioning properly**
Follow above for Amber and Red light conditions
- **LST/MC not being activated with each flush**
System must be activated with each flush
- **Treatment unit not being stored properly**
See Storage under Maintenance

CONTROL MODULE

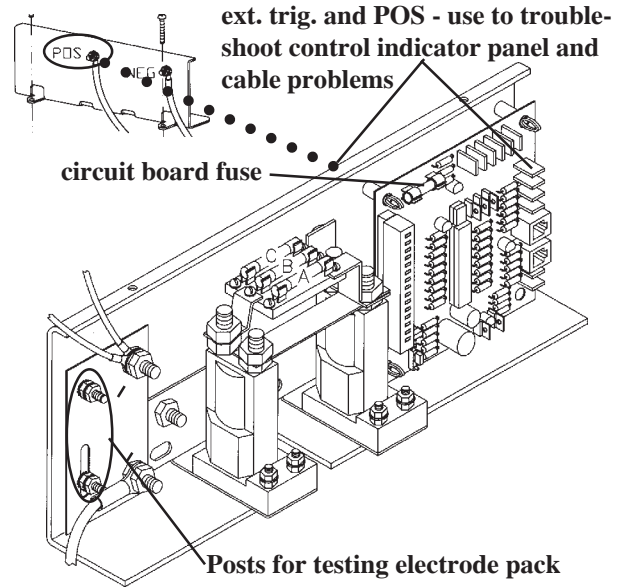

Troubleshooting some of the system functions:

Panel and cable problems:

Using a short piece of wire with an alligator clip at one end. Clip alligator end to ext. trig. tab on circuit board and momentarily touch POS post on control module.

- If cycle starts - replace panel and cable
- If cycle does not start - replace circuit board

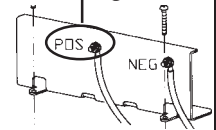

Electrode Pack:

use a digital meter set for milli-volts DC. Connect to the posts as shown in diagram above:

- 18 milli-volts or higher – OK
- 14 milli-volts or lower – Try Treatment/Electrode Cleaning procedure in manual. If cleaning does not improve milli-volts, possible Electrode Plate failure. Call Raritan Customer Service.

NOTE: Low milli-volts will also occur if the Lectra/San tank is not filled with a 4% saltwater solution. Contact Raritan Customer Service.

EXPLODED PARTS VIEW

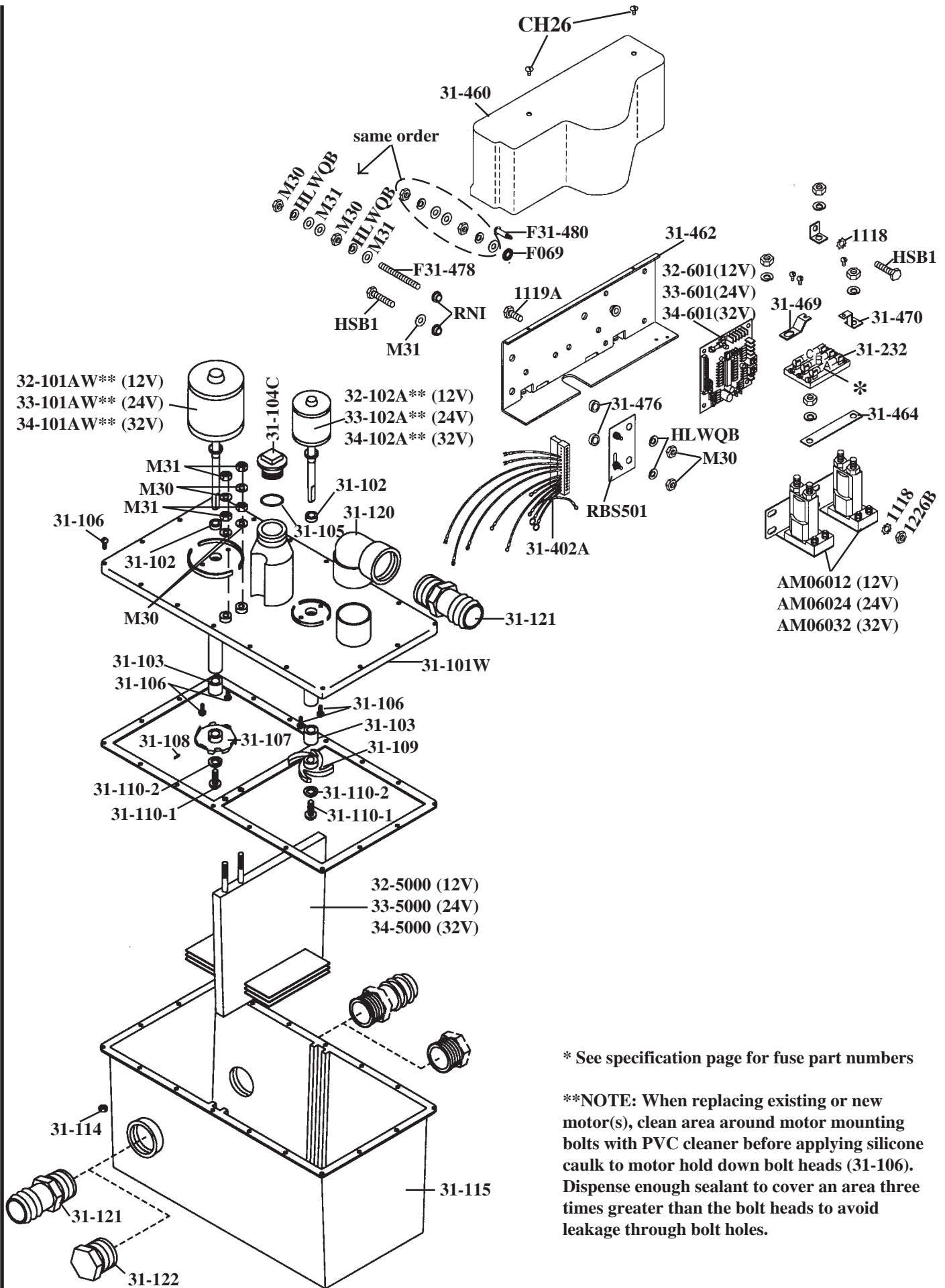

TREATMENT UNIT

Part No.	Description
32-102A**	Mixer Motor 2 1/2" Dia. 12 VDC
33-102A**	Mixer Motor 2 1/2" Dia. 24 VDC
34-102A**	Mixer Motor 2 1/2" Dia. 32 VDC
31-121	Hose Fitting (2)
31-120	Discharge Elbow 90°
M30	Electrode Flat Washer, 1/4", Brass (4)
M31	Electrode Lug Nut, 1/4"-20 Brass (4)
31-103	Motor Shaft Bushing (2)
31-106	10-32x7/8"RHMS,S/S (22)
31-109	Mixer Impeller
31-110-1	Impeller Bolt, 12-24x5/8", S/S (2)
31-110-2	Impeller Lock Washer, #12, S/S (2)
31-114	Cover Hold Down Nut, 10-32 (18)
31-115	Treatment Tank
31-122	Intake Plug
32-5000	Electrode Pack 12 VDC
33-5000	Electrode Pack 24 VDC
34-5000	Electrode Pack 32 VDC
31-112	Cover Gasket
31-108	Macerator Set Screw, 8-32x3/16", S/S
31-107	Macerator Impeller
31-101W	Treatment Cover (Inc. 7, 20,21 and 22)
31-104C	Crossover Plug
31-105	O-Ring
31-102	Motor Shaft Seal (2)
32-101AW**	Macerator Motor 3" Dia. 12 VDC
33-101AW**	Macerator Motor 3" Dia. 24 VDC
34-101AW**	Macerator Motor 3" Dia. 32 VDC
31-3001	Salt tank unit complete, two gallon (not shown)
31-3002	Four gallon salt feed tank (not shown)
32-3003	Four gallon salt feed tank w/12 volt pump (not shown)
33-3003	Four gallon salt feed tankw/24 volt pump (not shown)
32-4000*	12 V DC Complete Treatment Unit (less control module)
33-4000*	24 V DC Complete Treatment Unit (less control module)
34-4000*	32 V DC Complete Treatment Unit (less control module)

CONTROL MODULE

Part No.	Description
31-460	Control Cover
CH26	8-32 x 7/16" Truss head screw (2)
31-462	Mounting Plate
32-601	Circuit Board, 12V
33-601	Circuit Board, 24V
34-601	Circuit Board, 32V
EF5FA	F1 - 5 Amp Fuse, fast acting
AM06012	Solenoid Relay (2) - 12V
AM06024	Solenoid Relay (2) - 24V
AM06032	Solenoid Relay (2) - 32V
RBS501	Shunt 50 mv 50 amp LST/MC
31-402A	Wiring Harness Assy.
M30	1/4 - 20 Brass Nut (8)
HLWQB	1/4" Lockwasher (6)
M31	#14 Brass Flat Washer (7)
HSB1	1/4 - 20 Brass Cap Screw (2)
RNI	Nylon Shoulder Washer (3)
1119A	1/4 - 20 x 1/2" S/S Hex Head Machine Screw (4)
1118	1/4" External Tooth Washer (5)
1226B	1/4 - 20 S/S Hex Head Nut (4)
31-476	Nylon Spacer Washer (2)
F31-480	Nylon Stand Offs: PCB Supports (4)
F069	Gray Fiber Flat Washer
F31-478	Threaded Rod 1/4 - 20 x 2" Brass
31-464	Bracket
31-232	Fuse Block
31-466	Bracket
31-469	Copper Bracket
31-468	Bracket (not shown)
31-470	Cond. Bracket
32-602	12V Assy. (incl. all above parts except 1 and 2)
33-602	24V Assy. (incl. all above parts except 1 and 2)
34-602	32V Assy. (incl. all above parts except 1 and 2)
31-603	Control Indicator Panel (not shown)
31-604	Control Indicator Panel Cable (not shown)
31-605	Activator Assembly for Manual Toilets (not shown)
31-606	Pressure Switch for the Activator (not shown)

EXPLODED PARTS LIST

() Indicates Total pieces required

INSTALLATION OPTIONS FOR THE LECTRA/SAN MC SYSTEM

The Lectra/San MC has a variety of installation options including:

- 1) Installation with two marine toilets
- 2) Installation on Inspected Vessels
- 3) Direct circuit board connection when installed with the Raritan Atlantes
- 4) Connection to the Sealand VacuFlush®
- 5) Automatic activation from a manual toilet

All of the above options are covered by Technical bulletins available from Raritan by calling: 856-825-4900 or faxing in a request at: 856-825-4409 or on our website at: www.raritaneng.com

®Vacuflush is a registered trademark of Sealand Technology, Inc.

LIMITED WARRANTY

Raritan Engineering Company warrants to the original purchaser that this product is free of defects in materials or workmanship for a period of one year from the product's date of purchase. Should this product prove defective by reason of improper workmanship and/or materials within the warranty period, Raritan shall, at its sole option, repair or replace the product.

1. TO OBTAIN WARRANTY SERVICE, Consumer must deliver the product prepaid, together with a detailed description of the problem, to Raritan at 530 Orange St., Millville, N.J. 08332, or 3101 SW 2nd Ave. Ft. Lauderdale, FL 33315. When requesting warranty service, purchaser must present a sales slip or other document which establishes proof of purchase. THE RETURN OF THE OWNER REGISTRATION CARD IS NOT A CONDITION PRECEDENT OF WARRANTY COVERAGE. However, please complete and return the owner Registration Card so that Raritan can contact you should a question of safety arise which could affect you.
2. THIS WARRANTY DOES NOT COVER defects caused by modifications, alterations, repairs or service of this product by anyone other than Raritan; defects in materials or workmanship supplied by others in the process of installation of this product; defects caused by installation of this product other than in accordance with the manufacturer's recommended installation instructions or standard industry procedures; physical abuse to, or misuse of, this product. This warranty also does not cover damages to equipment caused by fire, flood, external water, excessive corrosion or Act of God.
3. ANY EXPRESS WARRANTY NOT PROVIDED HEREIN, AND ANY REMEDY FOR BREACH OF CONTRACT WHICH BUT FOR THIS PROVISION MIGHT ARISE BY IMPLICATION OR OPERATION OF LAW, IS HEREBY EXCLUDED AND DISCLAIMED. ALL IMPLIED WARRANTIES SUCH AS THOSE OF MERCHANTABILITY AND OF FITNESS FOR A PARTICULAR PURPOSE, IF APPLICABLE, AS WELL AS ANY IMPLIED WARRANTIES WHICH MIGHT ARISE BY IMPLICATION OF LAW, ARE EXPRESSLY LIMITED TO A TERM OF ONE YEAR. SOME STATES DO NOT ALLOW LIMITATIONS ON HOW LONG A LIMITED WARRANTY LASTS, SO THE ABOVE LIMITATION MAY NOT APPLY TO YOU.
4. UNDER NO CIRCUMSTANCES SHALL RARITAN BE LIABLE TO PURCHASER OR ANY OTHER PERSONS FOR ANY SPECIAL OR CONSEQUENTIAL DAMAGES, WHETHER ARISING OUT OF BREACH OF WARRANTY, BREACH OF CONTRACT, OR OTHERWISE. SOME STATES DO NOT ALLOW THE EXCLUSION OR LIMITATION OF INCIDENTAL OR CONSEQUENTIAL DAMAGES, SO THE ABOVE LIMITATION OR EXCLUSION MAY NOT APPLY TO YOU.
5. No other person or entity is authorized to make any express warranty, promise or affirmation of fact or to assume any other liability on behalf of Raritan in connection with its products except as specifically set forth in this warranty.
6. This warranty gives you specific legal rights, and you may also have other rights which vary from state to state.



530 Orange Street, P.O. Box 1157, Millville, NJ 08332 USA
Telephone: 856-825-4900 FAX: 856-825-4409
www.raritaneng.com
Southern Office and Plant:
3101 SW Second Avenue, Fort Lauderdale, FL 33315 USA
Telephone: 954-525-0378 FAX: 954-764-4370