

IN-LINE STRAINER

The In-Line Strainer protects marine equipment and reduces toilet odors caused by sea water particles.

Benefits

- Inexpensive protection for expensive parts
- Easy to install and maintain
- Clear, high-strength plastic bowl
- Convenient ½" female NPT connections
- 20 mesh plastic removable filter for easy cleaning
- Reduces toilet odors caused by sea water particles
- Can be mounted away from pumps for convenient access
- Compact size
- Each unit is assembled by hand, individually tested and backed by Raritan's one-year Limited Warranty and legendary technical support team

Raritan manufactures equipment for pleasure boats throughout the world. Products include marine toilets, waste treatment systems, icemakers and water heaters.

Committed to the environment and preserving sea life, Raritan designs products to help maintain an environmental balance and ensure the quality of marine waters. In addition, the company has achieved ISO 9001 certification for quality.

Innovation Through Experience

IN-LINE STRAINER

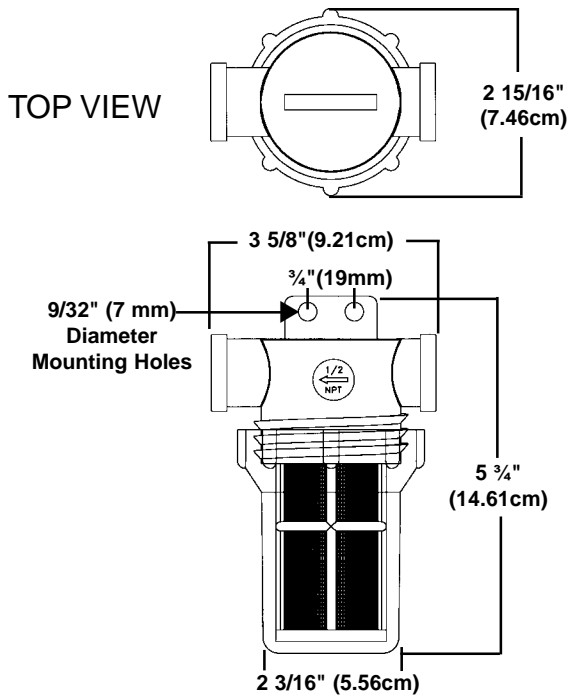

Install in an easily accessible location, above the waterline if possible. The arrows on the In-Line Strainer indicate the direction of flow.

Ports: 1/2" female NPT

Pressure Rating: 150 PSI @ 70°F
100 PSI @ 125°F

Approximate Shipping Weight: 1 lb (.5 kg)

Raritan's In-Line Strainer (#163000) removes debris from sea water which causes pumps to fail or operate inefficiently. The In-Line Strainer also helps eliminate unpleasant toilet odors by removing particles from the sea water that cause odor.

The In-Line Strainer bowl is made of durable clear plastic that enables the user to detect accumulation in the strainer filter. It can be mounted remotely for easy access.

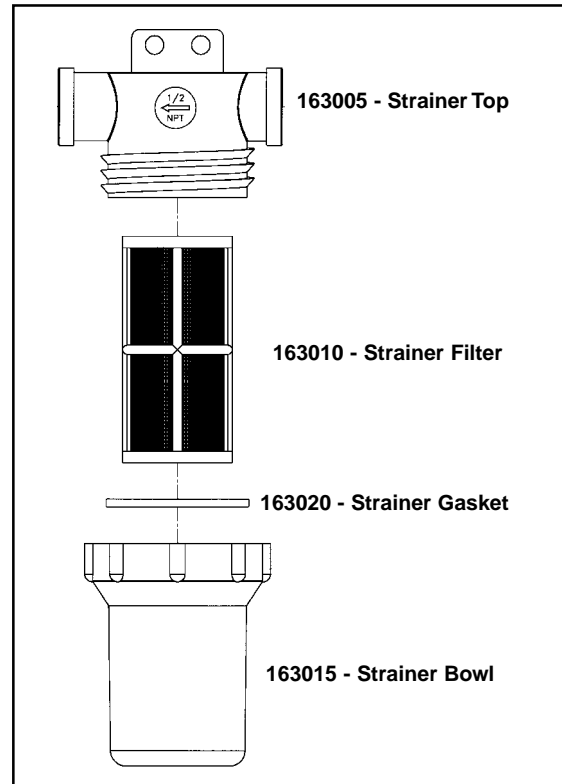

For more information contact:

530 Orange Street, PO Box 1157
Millville, NJ 08332, USA
Telephone: 856-825-4900
FAX: 856-825-4409
e-mail: info@raritaneng.com
www.raritaneng.com

Southern Plant and Office
3101 SW 2nd Avenue
Ft. Lauderdale, FL 33315 USA
Telephone: 954-525-0378
FAX: 954-764-4370

L1041s 0101srf



Innovation Through Experience