

2400T/2400T-PLUS ASSEMBLY

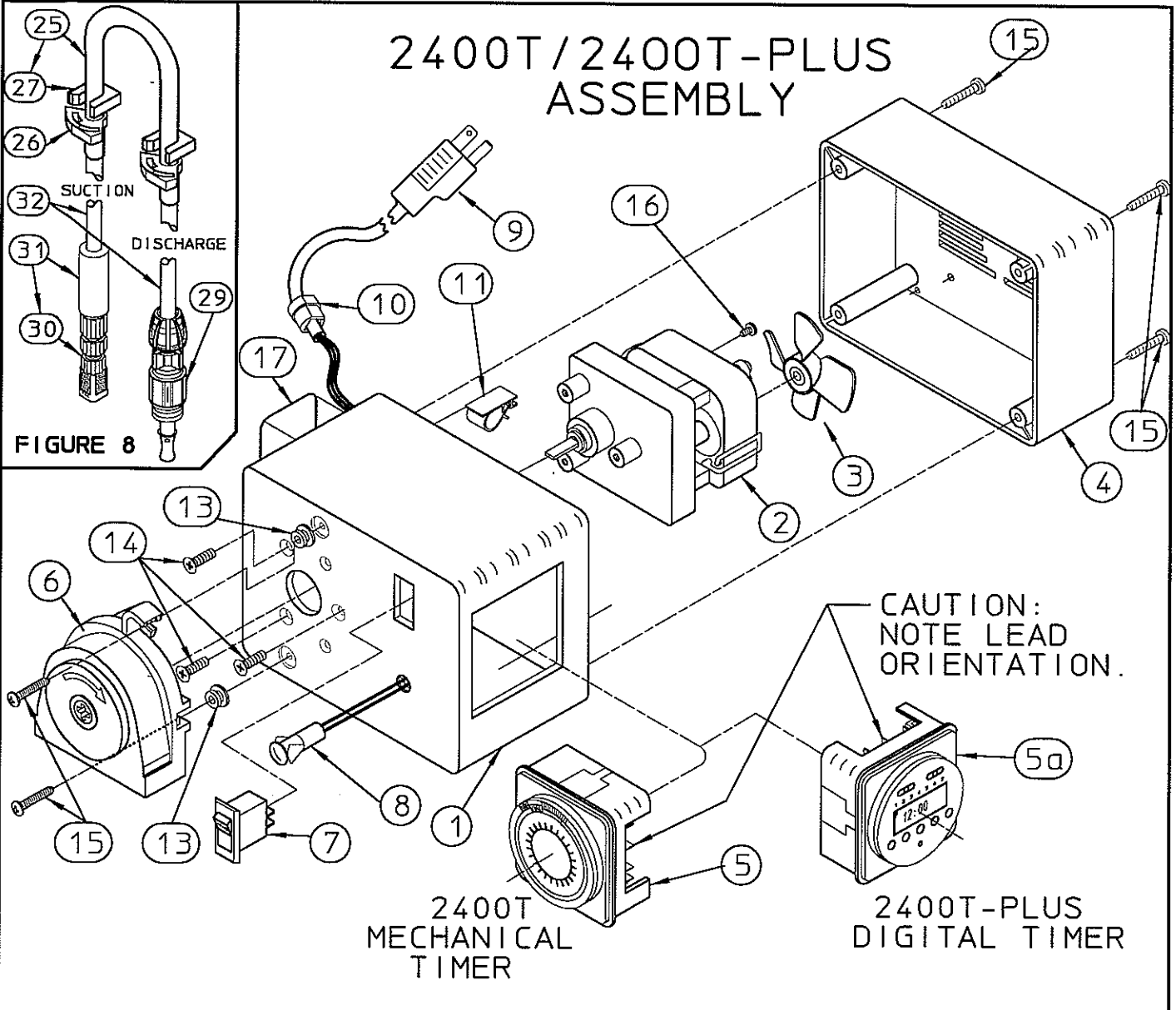

WIRING DIAGRAM

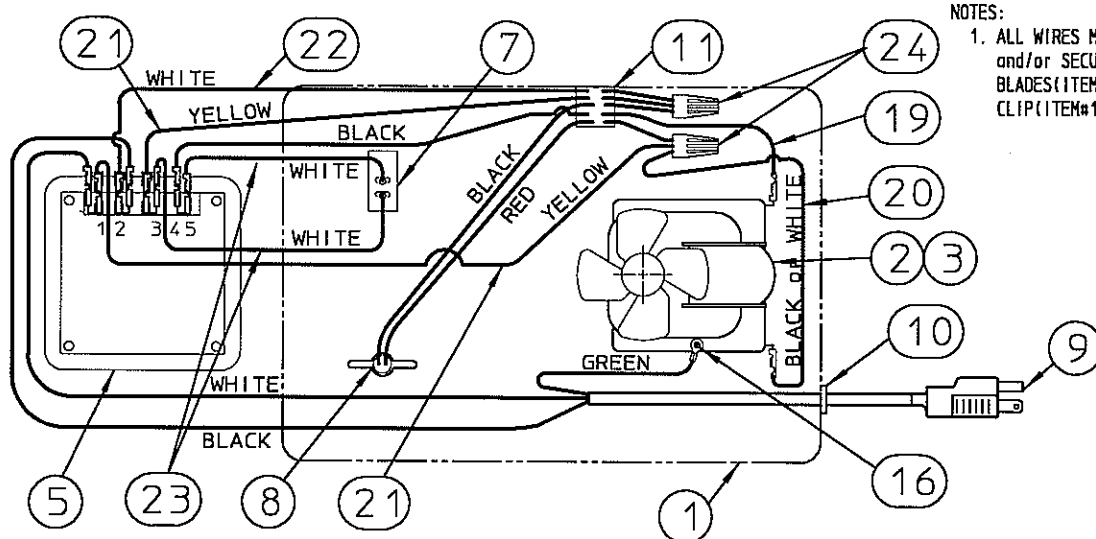

STANDARD 2400T AND 2400T-PLUS PARTS LIST/ BILL OF MATERIALS

ITEM	DESCRIPTION	PART#	QTY
1	PUMP HOUSING(2400T)	U0819144	1
	" " (2400T-PLUS)	U0819145	
2	MOTOR 5 rpm 120v/60Hz	U0818602	1
	" 5 rpm 230v/50/60Hz	U0818603	
3	FAN	U0818564	1
4	PUMP COVER	U0819143	1
5	TIMER 24h 120vAC/60hz(MECH.)	U0817952	1
	" 24h 230vAC/60hz(MECH.)	U0818652	
	" 24h 230vAC/50hz(MECH.)	U0818574	
5a	TIMER 120vAC/50-60hz(DIGITAL)	U0818740	1
	" 230vAC/50-60hz(DIGITAL)	NC960004-000	
6*	PUMP HEAD AS'Y(NO-PAD)	U8800753	1
7	SWITCH/PRIME	U0818061	1
8	INDICATOR LAMP 115v	U0818018	1
	" 230v	U0818647	
9	POWER CORD AS'Y. 120v	U0817433	1
	" 230v	U0817434	
10	STRAIN RELIEF	L9900700-000	1
11	WIRE CLIP	U0814047	1
12			
13	COLLAR, PERI HEAD	U0819132	2
14	SCREW,#10-32 x .688"lg.	U0817942	3
15	SCREW,#8-18x1.0"lg.	L9806200-188	6
16	SCREW,#6-32 x .25"lg.	U0812955	1
17	LABEL, DATA	---	1
19	LEAD AS'Y.w2 TERM.(BLACK) 7'	U0818557	1
20	LEAD AS'Y. (BLK. or WHT.) 6'	U0818556	1
21	LEAD AS'Y. (YELLOW) 4.5'	U0818084	2
22	LEAD AS'Y. (WHITE) 4.5'	U0818085	1
23	LEAD AS'Y.w/2 TERM. (WHT)4.5'	U0818086	2
24	WIRE NUT	U0501653	2
25+	SILICON TUBE ϕ .31" ASY	U0817131	1
26	HOSE CLAMP	U0817742	2
27	TUBE COLLAR(ϕ .31"-TUBE)	U0817122	REF
29	INJECTION FITTING	U8800712	1
30*	STRAINER AS'Y	J60552	1
31	STRAINER WEIGHT	L9906700-000	REF
32	TUBING 1/4" x 15'	U8800431	1

+ - INCLUDES TWO COLLARS(ITEM #27).

* - INCLUDES WEIGHT(ITEM #31).