

# PROSSER®

## INSTALLATION and OPERATION MANUAL STANDARD-LINE® Submersible Dewatering Pumps

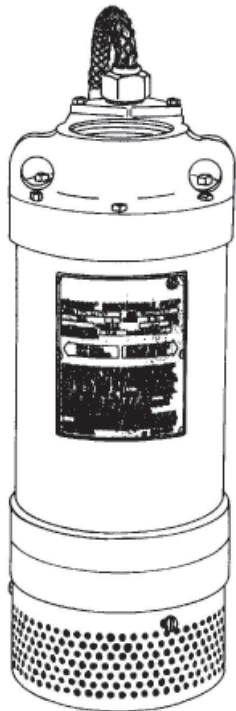

Series: 9-20000, 9-25000,  
9-27000, 9-35000,  
9-50000, \*9-55000

2HP thru 5HP, 3450RPM

\* 2 Stage Model

### IMPORTANT!

*Read all instructions in this manual before operating pump.*

*As a result of Crane Pumps & Systems, Inc., constant product improvement program, product changes may occur. As such Crane Pumps & Systems reserves the right to change product without prior written notification.*

**CRANE**<sup>®</sup>

A Crane Co. Company

### PUMPS & SYSTEMS

420 Third Street  
Piqua, Ohio 45356  
Phone: (937) 778-8947  
Fax: (937) 773-7157  
www.cranepumps.com

83 West Drive, Bramton  
Ontario, Canada L6T 2J6  
Phone: (905) 457-6223  
Fax: (905) 457-2650

Form No. 096926-Rev. L

# TABLE OF CONTENTS

|   |         |
|---|---------|
| SAFETY FIRST .....  | 3       |
| A. PUMP SPECIFICATIONS .....                                  | 4 - 5   |
| B. GENERAL INFORMATION .....                                  | 6       |
| C. INSTALLATION .....   | 6 - 8   |
| ELECTRICAL DATA .....   | 9       |
| D. START-UP OPERATION .....                                   | 8 - 10  |
| E. PREVENTATIVE MAINTENANCE .....                             | 10      |
| F. SERVICE and REPAIR .....                                   | 10 - 16 |
| G. REPLACEMENT PARTS.....                                     | 17      |
| TROUBLE SHOOTING .....  | 18      |
| CROSS-SECTION 9-20000 thru 9-50000 SERIES (Fig. 14) .....     | 19      |
| EXPLODED VIEW 9-20000 thru 9-50000 SERIES (Fig. 15) .....     | 20      |
| PARTS LIST 9-20000 thru 9-50000 SERIES .....                  | 21 - 22 |
| CROSS-SECTION 9-55000 2-Stage SERIES (Fig. 16).....           | 23      |
| EXPLODED VIEW 9-55000 2-Stage SERIES (Fig. 17).....           | 24      |
| PARTS LIST 9-55000 2-Stage SERIES .....                       | 25 - 26 |
| NEMA 3R (RainProof) CONTROL, CROSS-SECTION & PARTS LIST.....  | 27      |
| NEMA 4 (WaterTight) CONTROL, CROSS-SECTION & PARTS LIST ..... | 28      |
| TABLE 4, Capacitors and Circuit Breakers .....                | 29      |
| CONTROL SCHEMATIC (Fig. 20) .....                             | 29 - 30 |
| GALVANIC PROTECTION KIT .....                                 | 30      |
| SERIES ADAPTER KITS .....                                     | 31      |
| RETURNED GOODS POLICY.....                                    | 31      |
| WARRANTY .....  | 32      |
| START-UP REPORT .....   | 33 - 34 |
| WARRANTY REGISTRATION   |         |
| SPECIAL TOOLS AND EQUIPMENT                                   |         |
| INSULATION TESTER (MEGGER)                                    |         |
| DIELECTRIC TESTER   |         |
| SEAL TOOL KIT ( see parts list)                               |         |
| PRESSURE GAUGE KIT (see parts list)                           |         |

# SAFETY FIRST!

Please Read This Before Installing Or Operating Pump.  
This information is provided for **SAFETY and to PREVENT EQUIPMENT PROBLEMS**. To help recognize this information, observe the following symbols:



**IMPORTANT!** Warns about hazards that can result in personal injury or Indicates factors concerned with assembly, installation, operation, or maintenance which could result in damage to the machine or equipment if ignored.

**CAUTION !** Warns about hazards that can or will cause minor personal injury or property damage if ignored. Used with symbols below.

**WARNING !** Warns about hazards that can or will cause serious personal injury, death, or major property damage if ignored. Used with symbols below.



Hazardous fluids can cause fire or explosions, burnes or death could result.



Extremely hot - Severe burnes can occur on contact.



Biohazard can cause serious personal injury.



Hazardous fluids can Hazardous pressure, eruptions or explosions could cause personal injury or property damage.



Rotating machinery Amputation or severe laceration can result.



Hazardous voltage can shock, burn or cause death.

Only qualified personnel should install, operate and repair pump. Any wiring of pumps should be performed by a qualified electrician.



**WARNING ! -** To reduce risk of electrical shock, pumps and control panels must be properly grounded in accordance with the National Electric Code (NEC) or the Canadian Electrical Code (CEC) and all applicable state, province, local codes and ordinances.



**WARNING! -** To reduce risk of electrical shock, always disconnect the pump from the power source before handling or servicing. Lock out power and tag.



**WARNING!** Operation against a closed discharge valve will cause premature bearing and seal failure on any pump, and on end suction and self priming pump the heat build may cause the generation of steam with resulting dangerous pressures. It is recommended that a high case temperature switch or pressure relief valve be installed on the pump body.



**CAUTION !** Never operate a pump with a plug-in type power cord without a ground fault circuit interrupter.



**CAUTION!** Pumps build up heat and pressure during operation-allow time for pumps to cool before handling or servicing.



**WARNING! - DO NOT** pump hazardous materials (flammable, caustic, etc.) unless the pump is specifically designed and designated to handle them.



Do not block or restrict discharge hose, as discharge hose may whip under pressure.



**WARNING! - DO NOT** wear loose clothing that may become entangled in the impeller or other moving parts.



**WARNING! -** Keep clear of suction and discharge openings. **DO NOT** insert fingers in pump with power connected.



Always wear eye protection when working on pumps.



Make sure lifting handles are securely fastened each time before lifting. **DO NOT** operate pump without safety devices in place. Always replace safety devices that have been removed during service or repair. Secure the pump in its operating position so it can not tip over, fall or slide.



**DO NOT** exceed manufacturers recommendation for maximum performance, as this could cause the motor to overheat.



**DO NOT** remove cord and strain relief. Do not connect conduit to pump.



**WARNING!** Cable should be protected at all times to avoid punctures, cut, bruises and abrasions - inspect frequently. Never handle connected power cords with wet hands.



**WARNING!** To reduce risk of electrical shock, all wiring and junction connections should be made per the NEC or CEC and applicable state or province and local codes. Requirements may vary depending on usage and location.



**WARNING!** Submersible Pumps are not approved for use in swimming pools, recreational water installations, decorative fountains or any installation where human contact with the pumped fluid is common.



**WARNING!** Products Returned Must Be Cleaned, Sanitized, Or Decontaminated As Necessary Prior To Shipment, To Insure That Employees Will Not Be Exposed To Health Hazards In Handling Said Material. All Applicable Laws And Regulations Shall Apply.



Bronze/brass and bronze/brass fitted pumps may contain lead levels higher than considered safe for potable water systems. Lead is known to cause cancer and birth defects or other reproductive harm. Various government agencies have determined that leaded copper alloys should not be used in potable water applications. For non-leaded copper alloy materials of construction, please contact factory.



**IMPORTANT! -** Crane Pumps & Systems, Inc. is not responsible for losses, injury, or death resulting from a failure to observe these safety precautions, misuse or abuse of pumps or equipment.

**SECTION: A - PUMP SPECIFICATIONS:**

**LIQUID TEMPERATURE** .....140°F (60°C)  
**DISCHARGE CASE** .....356T6 Aluminum, Hard Anodized  
**DIFFUSER**.....356T6 Aluminum, Hard Anodized  
**SUCTION CASE** .....356T6 Aluminum, Hard Anodized with wear resistant polyurethane liner  
**FRAME & OUTER CASE**.....6063T6 Aluminum, Hard Anodized  
**WEAR PLATE** .....Polyurethane  
**PUMP SHAFT** .....Stainless Steel  
**IMPELLER** .....Hardened 17-4 Stainless Steel  
**HARDWARE** .....Stainless Steel  
**O-RINGS** .....Buna  
**SEAL:**     *Design* .....Tandem Mechanical, Oil Lubricated  
**INBOARD:**    *Material*.....Rotating Faces - Carbon  
   Stationary Faces - Ceramic  
   Elastomer - Buna-N  
   Hardware -300 Series Stainless  
**OUTBOARD:**  *Material*.....Rotating Faces - Silicon Carbide  
   Stationary Faces - Silicon Carbide  
   Elastomer - Viton®  
   Hardware - 300 Series Stainless  
**STRAINER** .....300 Series Stainless Steel .25" (6.35mm) Holes  
**UPPER BEARING:**  
        *Design* .....Single Row, Shielded, Ball  
        *Lubrication*.....Prelubricated high-temperature grease  
        *Load* .....Radial  
**LOWER BEARING:**  
        *Design* .....Single Row, Shielded, Ball  
        *Lubrication*.....Prelubricated high-temperature grease  
        *Load* .....Radial & Thrust  
**CORD ENTRY** .....50 ft. (15m) Strain Relief and Pressure Grommet for Sealing  
**MOTOR:**    *Design* .....NEMA L - Single Phase, NEMA B - Three Phase Torque Curve. Squirrel Cage Induction  
                   *Insulation* .....Class F  
**CONTROL:**    *Single Phase* .....Rainproof, NEMA 3R, Provides overload and short circuit protection,  
   Start & Run Capacitors, ON-OFF Switch  
                   *Three Phase*.....Rainproof, NEMA 3R, Provides Circuit Breaker for overload and  
   short circuit protection  
**OPTIONAL EQUIPMENT**.....Watertight, NEMA 4 Control, Series Adapter Kit, Carrying Handle, Viton® Seals,

**WARRANTY INVALID IF CORRECT PROSSER CONTROL IS NOT USED AT ALL TIMES.**

| PUMP SERIES | WEIGHT        |              |                    | SHIPPING WT./STD. UNIT PUMP, CORD & CONTROL |                     |
|-------------|---------------|--------------|--------------------|---|---------------------|
|             | PUMP ONLY     | CONTROL      | CORD               | DOMESTIC                                    | EXPORT              |
| 9-20000     | 48lbs./21.8kg | 8lbs./3.6kg  | .27lbs./Ft./40kg/m | 77lbs./34.9kg                               | 112lbs./3.6 Cu. Ft. |
| 9-25000     | 50lbs./22.7kg | 12lbs./5.4kg | .27lbs./Ft./40kg/m | 78lbs./35.4kg                               | 113lbs./3.6 Cu. Ft. |
| 9-27000     | 50lbs./22.7kg | 12lbs./5.4kg | .27lbs./Ft./40kg/m | 79lbs./35.8kg                               | 114lbs./3.6 Cu. Ft. |
| 9-35000     | 61lbs./28kg   | 12lbs./5.4kg | .27lbs./Ft./40kg/m | 90lbs./41kg                                 | 127lbs./4.2 Cu. Ft. |
| 9-50000     | 64lbs./29kg   | 12lbs./5.4kg | .27lbs./Ft./40kg/m | 93lbs./42kg                                 | 130lbs./4.2 Cu. Ft. |
| 9-55000     | 73lbs./33kg   | 12lbs./5.4kg | .27lbs./Ft./40kg/m | 102lbs./46kg                                | 139lbs./4.5 Cu. Ft. |

**IMPORTANT !**

- 1.) PUMP MAY BE OPERATED "DRY" FOR EXTENDED PERIODS WITHOUT DAMAGE TO MOTOR AND/OR SEALS.
- 2.) THIS PUMP IS APPROPRIATE FOR THOSE APPLICATIONS SPECIFIED AS CLASS I DIVISION II HAZARDOUS LOCATIONS. THE CONTROL SUPPLIED WITH THE PUMP IS NOT APPROPRIATE FOR HAZARDOUS LOCATIONS.
- 3.) THIS PUMP IS NOT APPROPRIATE FOR THOSE APPLICATIONS SPECIFIED AS CLASS I DIVISION I HAZARDOUS LOCATIONS.
- 4.) INSTALLATIONS SUCH AS DECORATIVE FOUNTAINS OR WATER FEATURES PROVIDED FOR VISUAL ENJOYMENT MUST BE INSTALLED IN ACCORDANCE WITH THE NATIONAL ELECTRIC CODE ANSI/NFPA 70 AND/OR THE AUTHORITY HAVING JURISDICTION. THIS PUMP IS NOT INTENDED FOR USE IN SWIMMING POOLS, RECREATIONAL WATER PARKS, OR INSTALLATIONS IN WHICH HUMAN CONTACT WITH PUMPED MEDIA IS A COMMON OCCURRENCE.

inches  
(mm)

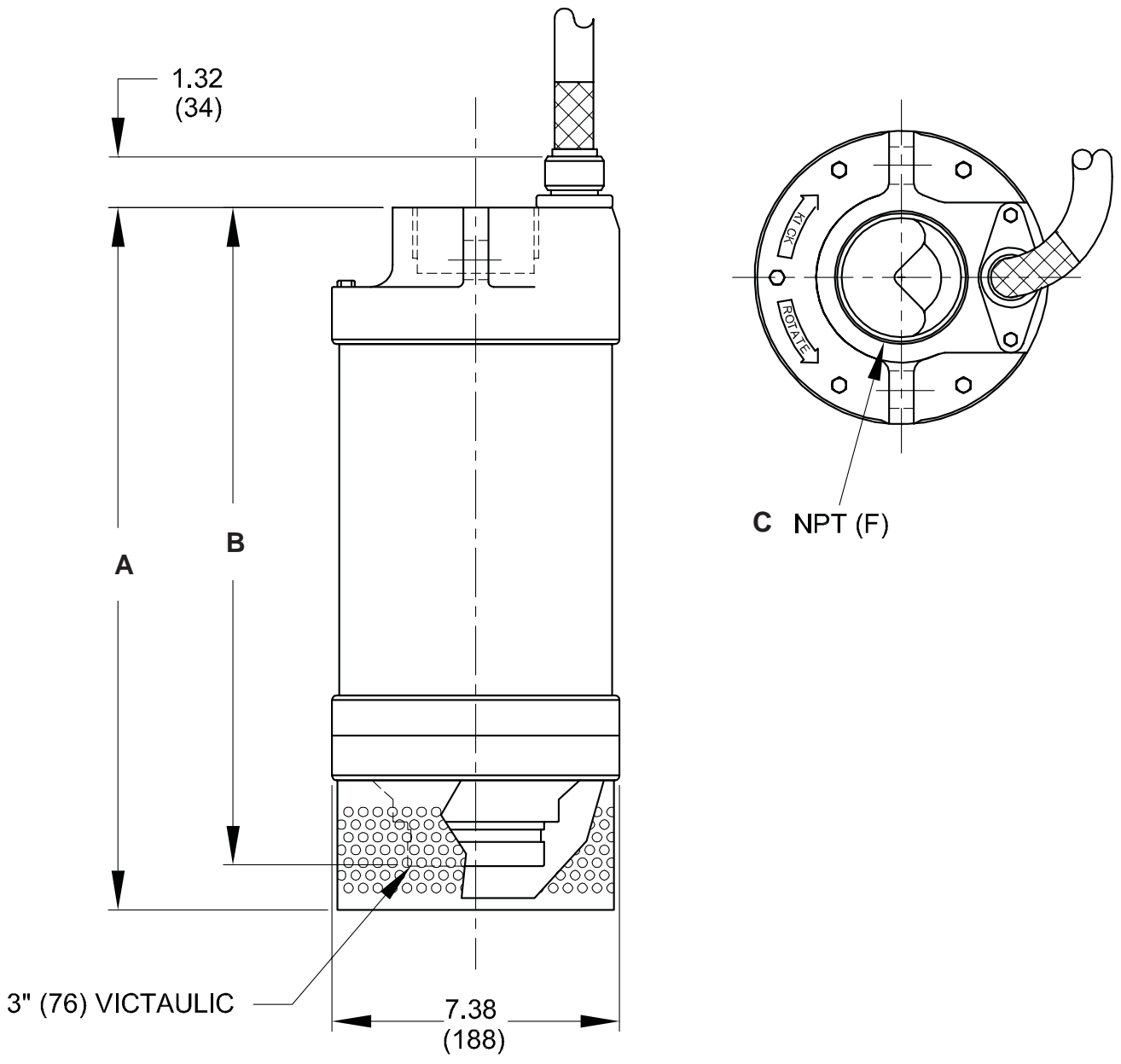

| PUMP SERIES | A           | B           | C      |
|-------------|-------------|-------------|--------|
| 9-20000     | 18.00 (457) | 16.88 (429) | 2 (51) |
| 9-25000     | 18.00 (457) | 16.88 (429) | 2 (51) |
| 9-27000     | 18.00 (457) | 16.88 (429) | 3 (76) |
| 9-35000*    | 21.18 (538) | 20.00 (508) | 3 (76) |
| 9-50000     | 21.44 (545) | 20.25 (514) | 3 (76) |
| 9-55000     | 24.25 (616) | 23.02 (585) | 2 (51) |

(\* Can be either 2" or 3" Discharge

## SECTION B: GENERAL INFORMATION

### B-1) To the Purchaser:

Congratulations! You are the owner of one of the finest pumps on the market today. These pumps are products engineered and manufactured of high quality components. Over one hundred years of pump building experience along with a continuing quality assurance program combine to produce a pump which will stand up to the toughest applications.

This manual will provide helpful information concerning installation, maintenance, and proper service guidelines.

### B-2) Receiving:

Upon receiving the pump, it should be inspected for damage or shortages. If damage has occurred, file a claim immediately with the company that delivered the pump. If the manual is removed from the packaging, do not lose or misplace.

### B-3) Storage:

**Short Term** - Prosser Pumps are manufactured for efficient performance following short inoperative periods in storage. For best results, pumps can be retained in storage, as factory assembled, in a dry atmosphere with constant temperatures for up to six (6) months.

**Long Term** - Any length of time exceeding six (6) months, but not more than twenty four (24) months. The units should be stored in a temperature controlled area, a roofed over walled enclosure that provides protection from the elements (rain, snow, wind-blown dust, etc.), and whose temperature can be maintained between +40 deg. F and +120 deg. F. If extended high humidity is expected to be a problem, all exposed parts should be inspected before storage and all surfaces should then be sprayed with a rust-inhibiting oil.

Pump should be stored in its original shipping container. On initial start up, rotate impeller by hand to assure seal and impeller rotate freely. If it is required that the pump be installed and tested before the long term storage begins, such installation will be allowed provided:

- 1.) The pump is not installed under water for more than one (1) month.
- 2.) Immediately upon satisfactory completion of the test, the pump is removed, thoroughly dried, repacked in the original shipping container, and placed in a temperature controlled storage area.

### B-4) Service Centers:

For the location of the nearest Prosser Service Center, check your Prosser representative or Crane Pumps & Systems, Inc., Service Department in Piqua, Ohio, telephone (937) 778-8947 or Crane Pumps & Systems Canada, Bramton, Ontario, (905) 457-6223.

## SECTION C: INSTALLATION

### C-1) Location:

These pumping units are self-contained and are recommended for well type pre-dewatering of building sites or pipelines, sumping and dewatering of coffer dams, caissons and tunnels, for dewatering of manholes and transformer vaults, construction sites and for emergency service, for shipboard dewatering of cargo holds and tanks, for damage control or ballast transfer and for general use in shipyards, dry-docks or off-shore rigs.

Before pumping fluids other than water, consult the factory, giving fluid, fluid temperature, specific gravity, viscosity, capacity in USGPM and total head and/or pressure requirements, including friction loss through discharge line, fittings, valves, etc. Maximum fluid temperature for sustained operation is 140°F (60°C) at specific gravity 1.0. Pump may run dry for reasonable period in air without damage where air can circulate freely through pump. **DO NOT** allow pump to be buried in mud or sand.



**IMPORTANT ! - Pump should have strainer affixed at all times. Inspect and clean the pump strainer periodically for maximum efficiency and performance.**

### C-2) Discharge:

Discharge hose is recommended. If rigid pipe is used, install so that there is no weight or strain on the pump.

#### C-2.1) Series Connection: (Optional)

The In-Line suction and discharge permits multiple pumps to be operated in series where the discharge of one pump is directly connected to the suction of another with the use of an adapter kit. Two small pumps instead of one large one enables the user to meet high head requirements on one job and separate the pumps to meet lower head requirements on the next.

When a group of pumps are SERIES connected the appropriate SERIES ADAPTER KIT (See page 31) should be used. It is important to remember that all the weight should not be carried through the pump housings. This is particularly important where the "spacing" method is used. Each pump is supplied with attachment points so that they may be steel cable supported for lifting, lowering or supporting (See Figure 1). **NEVER LIFT OR SUPPORT THE PUMP BY ITS ELECTRICAL CABLE !**

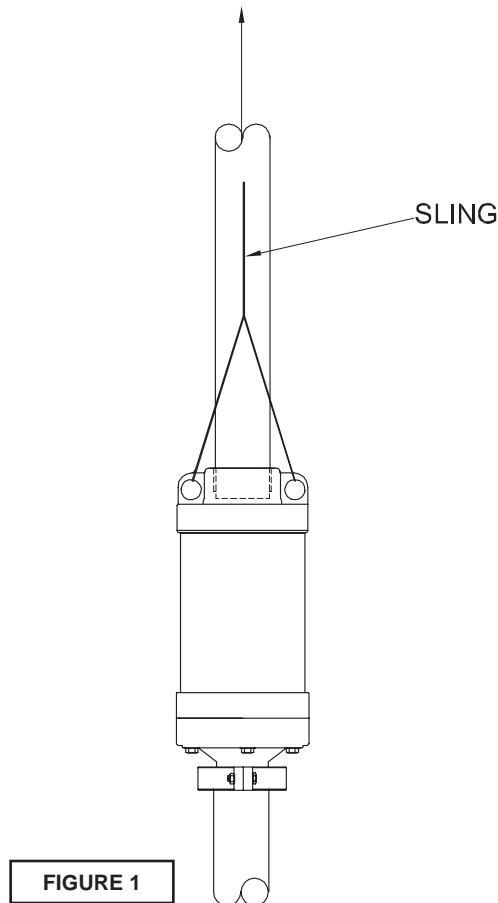

Each pump must be treated as an individual unit as far as cabling and overload protection is concerned. Individual cables must be run up to each pump controller for proper protection. Provide suitable protection for the cable rubbing against the caisson. This is particularly important around the pump housing of the upper pumps. PVC pipe or steel braiding may be in order in extreme cases of tight clearances. Some have crimped (both ends) stove pipe around the cable and pump (See Fig. 2).

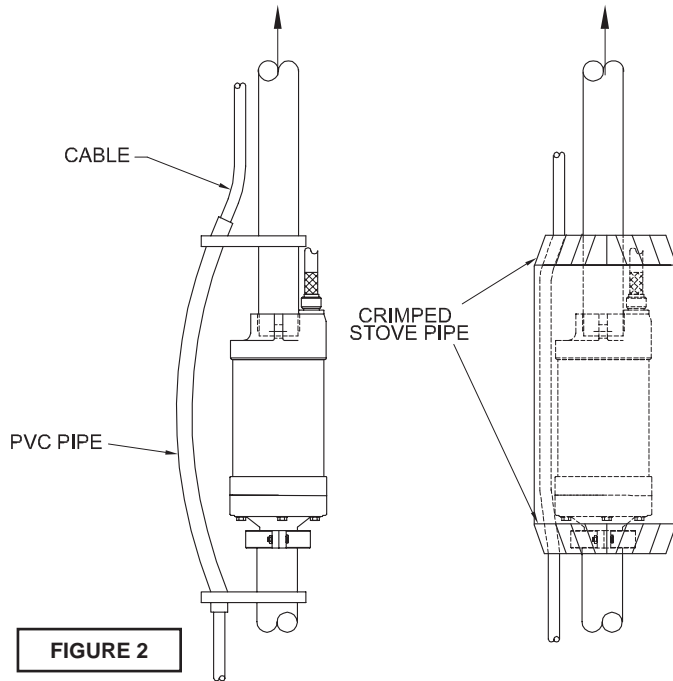

Check valves in a clean system where no or small amounts of solids are entrained, will not be troublesome. If they leak, no harm will be done. It should be noted that substantial amounts of solids will tend to block check valves after shutdown. If check valves are placed in an "S" bend ABOVE the lowest point, solids will drop out below the valve (See Fig. 3).

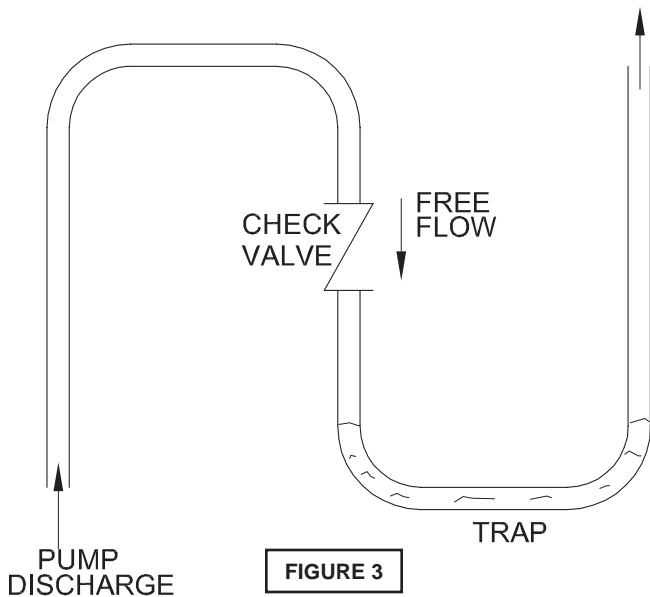

**C-2.2) Series Connection of Dissimilar Pumps:** (Optional) In some cases where high heads and relatively low-flow rates are desired at the most economic cost, two or more different size pumps may be used.

**IT IS VERY IMPORTANT THAT THE FLOW RATE PRODUCED IS WITHIN THE CAPACITY OF THE SMALLER PUMP, PUMP B.** If the system is flowing more than the smaller pump can handle, i.e., greater than  $Q$ , the smaller pump, Pump B, will actually retard the flow, and can induce cavitation in Pump A. To predict the performance, simply add the heads produced at a particular flow rate,  $H_T = H_A + H_B$ . (See Fig. 4).

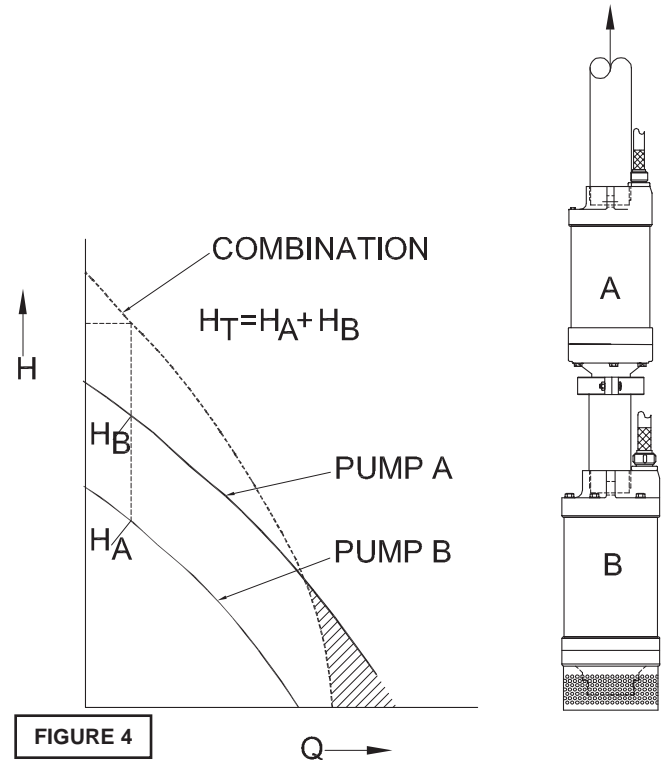

**C-3) Liquid Level Controls:** (If Applicable)

Attach "ON" float to discharge hose or pump cable at desired pump "ON" level. Attach "OFF" float to discharge hose or pump cable at desired pump "OFF" level. The "OFF" float must be below the "ON" float. To attach the floats, thread the cable strap through the buckle with the ratchet pawl, cinch up tight, thread excess strapping through outer buckle slot. Be certain that the level controls cannot hang up or foul in its swing. It is recommended that the pump is completely submerged when the level control is in the "Off" mode.

**C-4) Galvanic Protection Kit:** (If Applicable)

For protection against Electrolytic action, whether in saltwater or in other reactionary applications, the Galvanic Protection Kit is a proven method for protecting the pump against corrosion by using a Zinc Anode fitted to the pump. See page 30.

**C-5) Electrical Cords:**

**C-5.1) Power Cord:**

The cord assembly mounted to the pump must not be modified in any way except for shortening to a specific application. Any splice between the pump and the control panel must be made in accordance with the electric codes. Install and pull pumps only by attaching a rope or cable to the lifting lugs or handles provided on the pump. Cable should be protected at all times to avoid punctures and cuts. Do not use the power cable to lift pump. **DO NOT DROP PUMPS!**

**C-5.2) Wire Size:**

Transmission of power from source to pump control should be accomplished with sufficiently large 4 conductor cable of heavy duty type to prevent excessive voltage drop under full load conditions. Voltage supplied to pump must not vary more than plus or minus 10% of rated pump voltage, measured at motor terminal. Voltage must be balanced phase to phase within 5%. See above table for electrical information.

| PUMP SERIES | MAX. CORD LENGTH |
|-------------|------------------|
| 9-20111     | 127 Ft./39m      |
| 9-20112     | 197 Ft./60m      |
| 9-25132     | 530 Ft./161m     |
| 9-25134     | 2130 Ft./649m    |
| 9-25135     | 3350 Ft./1021m   |
| 9-27112     | 197 Ft./60m      |
| 9-35112     | 193 Ft./59m      |
| 9-50112     | 225 Ft./69m      |
| 9-50132     | 225 Ft./69m      |
| 9-50134     | 975 Ft./300m     |
| 9-50135     | 1375 Ft./423m    |
| 9-55132     | 245 Ft./75m      |
| 9-55134     | 982 Ft./299m     |
| 9-55135     | 1392 Ft./424m    |

**C-5.3) Overload Protection :**

**C-5.3-1) Single Phase** units utilize fuses in the control box for protection against motor damage due to locked rotor conditions and short circuits. A switch is provided for manual "ON - OFF" control. Before restarting pumps, check for correct voltage and phase. Also check for short circuits, cuts or breaks in cable and that connections are tight. If pump still won't start, pull unit for inspection. **DO NOT LET THE PUMP CYCLE OR RUN IF AN OVERLOAD CONDITION OCCURS !**

**C-5.3-2) Three Phase-** units control boxes utilizes a circuit breaker for pump overload, locked rotor or short circuit conditions and will disconnect the power to the pump if any of these conditions occur. Before restarting pumps, check for correct voltage and phase. Also check for short circuits, cuts or breaks in cable and that connections are tight. If pump still won't start, pull unit for inspection. **DO NOT LET THE PUMP CYCLE OR RUN IF AN OVERLOAD CONDITION OCCURS !**

 **WARNING! - Avoid repeated attempts to start motor. If motor fails to start after two attempts, pull pump and correct problem.**

**C-6) Control** - Mount the control above the ground to avoid seepage of dirt and water into control. This is critical or damage may occur. Control enclosure must be operated with cover closed.

**SECTION D: START-UP OPERATION**

**D-1) Check Voltage and Phase:**

Before operating pump, compare the voltage and phase information stamped on the pump's identification plate to the available power. Install proper safety ground connection to the green conductor to insure the motor, pump and control remains at ground potential, independent of the power supply. A metal well casing is one of the best available. Use voltmeter to make certain that voltage at pump control is within ± 10% of the rated voltage shown on the pump nameplate.

**D-2) Check Pump Rotation:**

Before putting pump into service for the first time, the motor rotation must be checked. Improper motor rotation can result in poor pump performance and can damage the motor and/or pump. To check the rotation, suspend the pump freely, momentarily apply power and observe the "Kick". "Kick" should always be in a clockwise direction as viewed from the top of the pump motor housing. Pump "Kick" is the opposite direction of pump rotation.

**D-2.1) Incorrect Rotation for Three-Phase Pumps:**

In the event that the rotation is incorrect for a three-phase installation, interchange any two power cable leads at the control box. **DO NOT** change leads in the cable housing in the motor. Recheck the "Kick" rotation again by momentarily applying power.

**D-2.2) Incorrect Rotation for Single-Phase Pumps:**

In the unlikely event that the rotation is incorrect for a single phase pump, contact a Prosser Service Center.

 **WARNING ! - DO NOT operate pump in reverse rotation as damage may result.**

**D-3) Start-Up:**

**DO NOT** attempt to start a frozen pump. Instead, submerge pump in water for twenty (20) minutes before starting. **DO NOT** attempt to thaw a frozen pump with a torch. Start pumps one at a time to avoid excessive current draw on power supply. When starting up pumps connected in series, turn on the bottom pump first, then the next to the bottom, etc (See Fig 5). When shutting down, turn off the top pump first and continue downward after allowing sufficient time for the water column to drain down to the next lower pump. This process reduces the chance of over-pressuring the lower seals when there are no system check valves or the units are spaced.

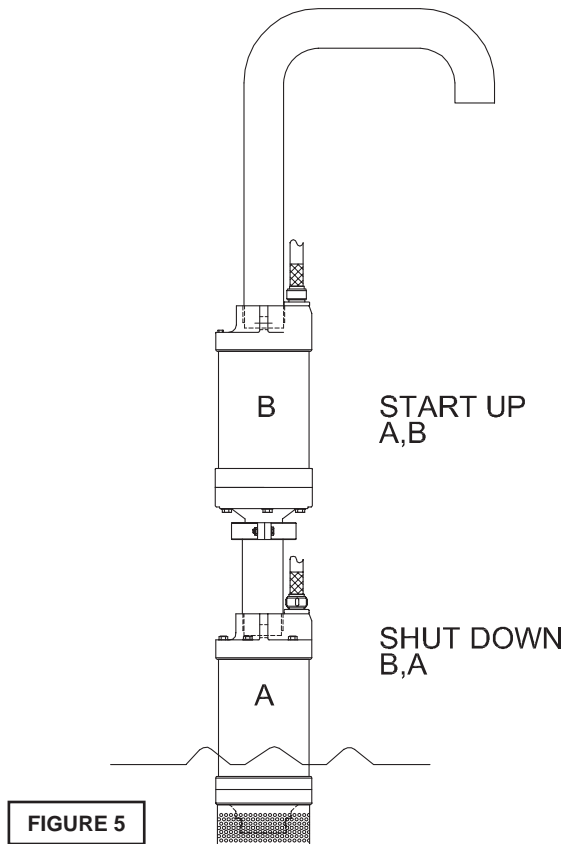

**FIGURE 5**



| PART NO.   | HP   | VOLT/<br>PH | Hz | RPM<br>(Nom) | NEMA<br>START<br>CODE | FULL<br>LOAD<br>AMPS | LOCKED<br>ROTOR<br>AMPS | CORD<br>SIZE | CORD<br>TYPE | CORD<br>OD | WINDING<br>RESISTANCE<br>W,B--R,B--R,W |
|--|------|-------------|----|--------------|-----------------------|----------------------|-------------------------|--------------|--------------|------------|--|
| <b>PUMP w/WATERTIGHT CONTROL</b>                     |      |             |    |              |                       |                      |                         |              |              |            |  |
| 9-20111-13   | 2.0  | 115/1       | 60 | 3450         | F                     | 23.4                 | 92.5                    | 12/4         | SOW          | 0.650      | 0.4 -- 1.5 -- 1.1                      |
| 9-20112-13   | 2.0  | 230/1       | 60 | 3450         | G                     | 11.7                 | 51.0                    | 12/4         | SOW          | 0.650      | 1.6 -- 5.8 -- 4.2                      |
| <b>PUMP w/RAINPROOF CONTROL</b>                      |      |             |    |              |                       |                      |                         |              |              |            |  |
| 9-20111-14   | 2.0  | 115/1       | 60 | 3450         | F                     | 23.4                 | 92.5                    | 12/4         | SOW          | 0.650      | 0.4 -- 1.5 -- 1.1                      |
| 9-20112-14   | 2.0  | 230/1       | 60 | 3450         | G                     | 11.7                 | 51.0                    | 12/4         | SOW          | 0.650      | 1.6 -- 5.8 -- 4.2                      |
| 9-27112-03   | 2.75 | 230/1       | 60 | 3450         | D                     | 12.5                 | 52.6                    | 12/4         | SOW          | 0.650      | 1.6 -- 5.8 -- 4.2                      |
| 9-35112-03   | 3.5  | 230/1       | 60 | 3450         | F                     | 18.5                 | 84.0                    | 12/4         | SOW          | 0.650      | 0.85 -- 2.2 -- 2.2                     |
| 9-50132-03*  | 5.0  | 230/3       | 60 | 3450         | H                     | 15.5                 | 87.8                    | 12/4         | SOW          | 0.650      | 0.85 -- 0.85 -- 0.85                   |
| 9-50134-03*  | 5.0  | 460/3       | 60 | 3450         | H                     | 7.8                  | 43.9                    | 12/4         | SOW          | 0.650      | 3.6 -- 3.6 -- 3.6                      |
| 9-50135-03   | 5.0  | 575/3       | 60 | 3450         | H                     | 6.2                  | 35.1                    | 12/4         | SOW          | 0.650      | 5.2 -- 5.2 -- 5.2                      |
| 9-55132-03   | 5.0  | 230/3       | 60 | 3450         | H                     | 15.2                 | 87.8                    | 12/4         | SOW          | 0.650      | 0.85 -- 0.85 -- 0.85                   |
| 9-55134-03   | 5.0  | 460/3       | 60 | 3450         | H                     | 7.6                  | 43.9                    | 12/4         | SOW          | 0.650      | 3.6 -- 3.6 -- 3.6                      |
| 9-55135-03   | 5.0  | 575/3       | 60 | 3450         | H                     | 6.1                  | 35.1                    | 12/4         | SOW          | 0.650      | 5.2 -- 5.2 -- 5.2                      |
| <b>PUMP w/OPTIONAL WATERTIGHT CONTROL</b>            |      |             |    |              |                       |                      |                         |              |              |            |  |
| 9-27112-04   | 2.75 | 230/1       | 60 | 3450         | D                     | 12.5                 | 52.6                    | 12/4         | SOW          | 0.650      | 1.6 -- 5.8 -- 4.2                      |
| 9-35112-04   | 3.5  | 230/1       | 60 | 3450         | F                     | 18.5                 | 84.0                    | 12/4         | SOW          | 0.650      | 0.85 -- 2.2 -- 2.2                     |
| 9-50132-04*  | 5.0  | 230/3       | 60 | 3450         | H                     | 15.5                 | 87.8                    | 12/4         | SOW          | 0.650      | 0.85 -- 0.85 -- 0.85                   |
| 9-50134-04*  | 5.0  | 460/3       | 60 | 3450         | H                     | 7.8                  | 43.9                    | 12/4         | SOW          | 0.650      | 3.6 -- 3.6 -- 3.6                      |
| 9-50135-03   | 5.0  | 575/3       | 60 | 3450         | H                     | 6.2                  | 35.1                    | 12/4         | SOW          | 0.650      | 5.2 -- 5.2 -- 5.2                      |
| 9-55132-04   | 5.0  | 230/3       | 60 | 3450         | H                     | 15.2                 | 87.8                    | 12/4         | SOW          | 0.650      | 0.85 -- 0.85 -- 0.85                   |
| 9-55134-04   | 5.0  | 460/3       | 60 | 3450         | H                     | 7.6                  | 43.9                    | 12/4         | SOW          | 0.650      | 3.6 -- 3.6 -- 3.6                      |
| 9-55135-03   | 5.0  | 575/3       | 60 | 3450         | H                     | 6.1                  | 35.1                    | 12/4         | SOW          | 0.650      | 5.2 -- 5.2 -- 5.2                      |
| <b>HH SERIES PUMP w/RAINPROOF CONTROL</b>            |      |             |    |              |                       |                      |                         |              |              |            |  |
| 9-25132-03   | 2.5  | 230/3       | 60 | 3450         | J                     | 6.8                  | 49.2                    | 12/4         | SOW          | 0.650      | 2.0 -- 2.0 -- 2.0                      |
| 9-25134-03   | 2.5  | 460/3       | 60 | 3450         | J                     | 3.4                  | 24.6                    | 12/4         | SOW          | 0.650      | 8.0 -- 8.0 -- 8.0                      |
| 9-25135-03   | 2.5  | 575/3       | 60 | 3450         | J                     | 2.7                  | 19.7                    | 12/4         | SOW          | 0.650      | 10.4 -- 10.4 -- 10.4                   |
| <b>HV SERIES PUMP w/RAINPROOF CONTROL</b>            |      |             |    |              |                       |                      |                         |              |              |            |  |
| 9-25132-53   | 2.5  | 230/3       | 60 | 3450         | J                     | 7.8                  | 49.2                    | 12/4         | SOW          | 0.650      | 2.0 -- 2.0 -- 2.0                      |
| 9-25134-53   | 2.5  | 460/3       | 60 | 3450         | J                     | 3.9                  | 24.6                    | 12/4         | SOW          | 0.650      | 8.0 -- 8.0 -- 8.0                      |
| 9-25135-53   | 2.5  | 575/3       | 60 | 3450         | J                     | 3.0                  | 19.7                    | 12/4         | SOW          | 0.650      | 10.4 -- 10.4 -- 10.4                   |
| <b>HH SERIES PUMP w/ OPTIONAL WATERTIGHT CONTROL</b> |      |             |    |              |                       |                      |                         |              |              |            |  |
| 9-25132-04   | 2.5  | 230/3       | 60 | 3450         | J                     | 6.8                  | 49.2                    | 12/4         | SOW          | 0.650      | 2.0 -- 2.0 -- 2.0                      |
| 9-25134-04   | 2.5  | 460/3       | 60 | 3450         | J                     | 3.4                  | 24.6                    | 12/4         | SOW          | 0.650      | 8.0 -- 8.0 -- 8.0                      |
| 9-25135-04   | 2.5  | 575/3       | 60 | 3450         | J                     | 2.7                  | 19.7                    | 12/4         | SOW          | 0.650      | 10.4 -- 10.4 -- 10.4                   |
| <b>HV SERIES PUMP w/ OPTIONAL WATERTIGHT CONTROL</b> |      |             |    |              |                       |                      |                         |              |              |            |  |
| 9-25132-54   | 2.5  | 230/3       | 60 | 3450         | J                     | 7.8                  | 49.2                    | 12/4         | SOW          | 0.650      | 2.0 -- 2.0 -- 2.0                      |
| 9-25134-54   | 2.5  | 460/3       | 60 | 3450         | J                     | 3.9                  | 24.6                    | 12/4         | SOW          | 0.650      | 8.0 -- 8.0 -- 8.0                      |
| 9-25135-54   | 2.5  | 575/3       | 60 | 3450         | J                     | 3.0                  | 19.7                    | 12/4         | SOW          | 0.650      | 10.4 -- 10.4 -- 10.4                   |

Pump rated for operation at  $\pm 10\%$  voltage at motor.

Winding Resistance  $\pm 5\%$ .

For conversion of the above astric (\*) models from one phase and voltage to another use the conversion table below to determine conversion kit required.

| CONVERSION KITS - 60Hz         |      |    |       |     |    |       |                    |   |
|--------------------------------|------|----|-------|-----|----|-------|--------------------|---|
| PUMP<br>MODEL                  | FROM |    |       | TO  |    |       | CONVERSION KIT NO. | CONTENTS OF KITS  |
|                                | HP   | PH | VOLTS | HP  | PH | VOLTS |                    |   |
| 9-50112-03                     |      |    |       | 5.0 | 3  | 230   | 9-500871-03        | Impeller<br>Rainproof Control (For<br>Watertight Enclosure<br>- Refer to Factory)<br>Suction Case<br>Connectors |
|                                | 3.5  | 1  | 230   | 5.0 | 3  | 460   | 9-500872-03        |   |
| 9-50132-03<br>or<br>9-50134-03 | 5    | 3  | 230   |     |    |       | 9-500870-03        |   |
|                                | 5    | 3  | 460   | 3.5 | 1  | 230   |                    |   |

Refer to page 21, Section F-5.3 for Dual Phase /Dual Voltage Pump Models.



**CAUTION ! - When check valves are not used and a series system is accidentally shut down instantaneously (power failure), sufficient time must be allowed for pump impellers to stop rotating backwards before restarting.**

**NOTE:** Pressure inside 3" discharge pumps or smaller should not exceed 100 PSI (231 ft of Head). Pressure inside 4" discharge pumps or larger should not exceed 200 PSI (462 ft. of Head).

#### **D-3.1) Report:**

Included at the end of this manual is a start-up report sheet, this sheet is to be completed as applicable. Return one copy to the Crane Pumps & Systems, Inc. Service Department and store a copy in the control panel or with the pump manual if no control panel is used. It is important to record this data at initial start-up since it will be useful to refer to should servicing the pump be required in the future.

#### **D-3.2) Identification Plate:**

Record the numbers from the pump's identification plate on the START-UP REPORT provided at the end of the manual for future reference.

#### **D-3.3) Insulation Test:**

Before the pump is put into service, an insulation (megger) test should be performed on the motor. The resistance values (ohms) as well as the voltage (volts) and current (amps) should be recorded on the start-up report.

### **SECTION E: PREVENTIVE MAINTENANCE:**

Prosser pumps are CSA approved. The following procedure must be followed to assure proper pump operation and unit CSA approval integrity.

1.) **General Safety:** Frequent inspection shall be made. All electrical parts, including the portable cable and wiring, shall be kept in a safe condition. **KEEP CABLE GLAND NUTS TIGHT, CHECK FREQUENTLY.** There shall be no openings into the casing of the electrical parts. The machine frame shall be effectively grounded. The power wires shall not be used for grounding. The operating voltage shall match the voltage rating of the motor(s).

2.) **Servicing:** Pump and control enclosures shall be restored to the state of original safety with respect to all lead entrances, etc., following disassembly.

3.) **Renewals and Repairs:** Special care shall be taken in making renewals or repairs. Leave no parts off. Use replacement parts furnished by the manufacturer. When any lead entrance is disturbed, the original leads or exact duplicates thereof shall be used.

4.) **Fastenings:** All bolts, nuts, screws and other means of fastenings and also threaded covers, shall be in place, properly tightened and secured.

5.) **Cable Requirements:** A heavy usage, type SOW submersible cable shall be used. Special care shall be taken in handling the cable against mechanical injury and wear. Connections and wiring to the power source shall be in accordance with all local electrical and safety codes.

6.) **Shaft Seals:** The seals should be inspected every 1500 operating hours for wear (more often if abrasives are present). To make a quick check of the seal's condition, drain and inspect the oil in the seal chamber (See Section F-1). If oil removed from the pump contains water or abrasives, replace seals.

7.) **Amperage:** Amperage should be checked periodically (at least weekly) to be certain that it does not exceed limits recommended by manufacturer on pump nameplate.

8.) **Volts:** If a generator is the power source, check daily for variation of voltage and cycles.

This pump is equipped with prelubricated bearings.

When a job is completed and before pumps are stored, drain the oil from the seal chamber (a must before freezing weather). If dirt or water are found in the oil, replace seals, bearings, lower "O" rings and oil.

### **SECTION F: SERVICE AND REPAIR**

**NOTE:** All item numbers in ( ) refer to Figures 14 & 15 and 16 & 17 For 2-Stage Models.

#### **F-1) Electrical Inspection:**

When pumps are returned from a field operation, or when a pump needs repair, prior to disassembly, and after disconnecting the unit from the power source, make electrical inspection of the pump, cable and control box. The test can be done by using a megger and an ohmmeter.

#### **F-1.1) Insulation Resistance - Cord & Control:**

Use the megger to measure the insulation resistance. Attach the megger probes to the pump lead side of the circuit breaker in the control box, one probe to the ground lead and one probe to a pump power lead. Acceptable values of insulation resistance are 10 megohms or greater. If insulation resistance is below 10 megohms, the motor leads should be disconnected from the cord assembly so that the cord and motor can be tested separately.

Should the cable show insulation resistance of less than 10 megohms, disconnect from control box and attach megger probes to the individual leads within the cord. Values below 10 megohms of insulation resistance would indicate damage or moisture and cord should be replaced. Low values of insulation resistance below 10 megohms for the circuitry within the control box would indicate damage or moisture, Any bad parts should be replaced.

#### **F-1.2) Insulation Resistance - Motor:**

The insulation resistance of the motor stator can be measured by attaching one probe of the megger to the motor power leads and the other probe to the motor ground lead or to bare metal of the pump frame. Insulation resistance values under 10 megohms would indicate presence of excessive moisture within the stator winding. Such moisture can be removed from the stator by placing the stator and frame assembly in an oven and baking the assembly at 250°- 275°F for two to three hours. Following such baking, remeasure the insulation resistance to verify that a minimum of 10 megohms has been attained, if not, replace stator.



**WARNING ! - Always wear appropriate clothing and safety gear when working with or around oven.**

If low stator insulation resistance is due to other modes of failure, such as damaged leads, deformed end turns, etc, the stator should be replaced. Another test of the electrical integrity of the stator is the measurement of winding resistance with an ohmmeter. Such measurement is made between the leads of the stator. If the resistance of the stator winding is greater than listed on page 9, the stator should be replaced.

**F-2) Lubrication:**

**F-2.1) Checking Oil:**

To check oil, remove pipe plug (42) from diffuser (9). With a flashlight, visually inspect the oil in the seal cavity to make sure it is clean and clear, light amber in color and free from suspended particles. Milky white oil indicates the presence of water. If the the oil looks milky white, pour the oil out of the oil chamber and let it settle in a clean, dry container. If any water settles out in the bottom of the container or if the oil is white and thick (emulsified) replace rotary shaft seals (See Section F-4) and oil.

You can also check oil for contamination by using an oil tester with a range to 30 Kilovolts breakdown. If oil is found to be clean and uncontaminated (measure at or above 15 KV. breakdown), refill the seal cavity. If oil is found to be dirty or contaminated (or measures below 15 KV. breakdown), replace rotary seals and oil.

| TABLE 1 SEAL CHAMBER OIL |                     |
|--------------------------|---------------------|
| SUPPLIER                 | GRADE               |
| Gulf                     | (334206) Harmony 68 |
| Texaco                   | URSA P-68           |

**F-2.2) Replacing Oil:**

Remove pipe plug (42) from diffuser (9), and drain oil from seal chamber and dispose of properly. Flush inside seal chamber of diffuser (9) thoroughly to be sure it is clean and free of abrasives. Refill oil chamber with 5 Oz (150 ml), or about half full, of a 20W non-detergent turbine oil with rust and oxidation inhibitors, See Table 1. After replacing oil, replace pipe plug (42) using a sealant.

**F-2.3) Seal Cavity Pressure Test:**

Remove pipe plug (42) from diffuser (9) and check that the seal chamber is of the correct amount of oil (See Figure 6). Apply pipe sealant to pressure gauge assembly and tighten into hole in Intermediate diffuser (9). Pressurize seal chamber to 12 P.S.I. and check for leaks. If after five minutes, the pressure is still holding constant, and no leaks are observed, slowly bleed the pressure and remove the gauge assembly. Replace the pipe plug (42) using a sealant. If the pressure does not hold, then the leak must be located and repaired.



**CAUTION ! - Pressure builds up extremely fast, increase pressure by "TAPPING" air nozzle. Too much pressure will damage seal. DO NOT exceed 12 P.S.I.**

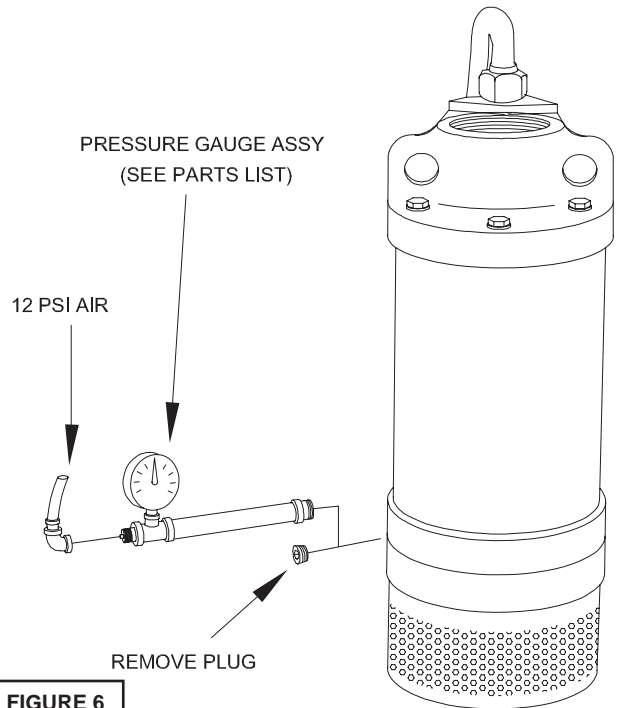

**FIGURE 6**

**F-3) Impeller Service:**

**F-3.1) Disassembly:**

To inspect or replace impeller (3) and impeller o-ring (43), remove screws (40) and remove strainer (24). Remove capscrews (32), flatwashers (49) and brackets (41) then remove suction case (4). Check the suction case (4) lining for wear, cuts, or defects and replace if necessary. Now remove locknuts (16) and washer (27) from shaft. The impeller (3) should slip off the shaft, if not, remove the o-ring (43) from the impeller groove and use a bearing puller. Inspect the impeller for wear or damage, also check shims (17a) & (17b) and replace if necessary. **NOTE:** Seal spring relaxes when impeller is removed and may cause oil to leak through.

**2-STAGE MODELS:** To inspect or replace impellers (3) and impeller o-rings (43), remove screws (40) and remove strainer (24). Remove capscrews (32), flatwashers (49) and brackets (41) then remove suction case (4) and o-ring (50). Check suction case (4) lining for wear, cuts, or defects and replace if necessary. Now remove locknut (16) and washer (27) from shaft. The outer impeller (3) should slip off the shaft, if not, remove the o-ring (43) from the impeller groove and use a bearing puller. Inspect the impeller for wear or damage, remove shims (17a), (17b), space (54), lower diffuser (51) and o-ring (50), replace if necessary.

The inner impeller (3) should slip off the shaft, if not, remove the o-ring (43) from the impeller groove and use a bearing puller. Inspect the impeller for wear or damage, remove shims (17a) and (17b). **NOTE:** Seal spring relaxes when impeller is removed and may cause oil to leak through.

**F-3.2) Reassembly:**

To reassemble, slide shims (17a) & (17b) onto shaft, then apply an anti-seize compound on the shaft area where the impeller fits. Insert o-ring (43) into groove on impeller (3) and slide the impeller (3) onto the shaft, replace washer (27) and two locknuts (16) as shown in Fig. 16, onto shaft and tighten to 37 ft lbs.

Replace suction case (4) onto diffuser (9) and brackets (41), lining up holes and inserting capscrews (32) with flatwashers (49) tightening to 5 Ft. lbs.

**2-STAGE MODELS:** To reassemble, (see Fig. 18) slide inner shims (17a) & (17b) onto shaft, then apply an anti-seize compound on the shaft area where the impeller fits. Insert o-ring (43) into groove on inner impeller (3) and slide the impeller (3) onto the shaft. Apply a grease to o-rings (50) and place on lower diffuser (51), then place lower diffuser assembly (51) onto upper diffuser (9). Slide spacer (54) and outer shims (17a) & (17b) onto shaft, then apply an anti-seize compound on the shaft area where the outer impeller fits.

Insert o-ring (43) into groove on outer impeller (3) and slide the impeller (3) onto the shaft, replace washer (27) and locknut (16) onto shaft and tighten to 103 ft lbs. Replace suction case (4) onto diffuser (9) and brackets (41), lining up holes and inserting capscrews (32) with flatwashers (49) tightening to 5 Ft. lbs.

After assembly, check that the impeller rotates smoothly, but with a slight drag due to bearing and rotary seal friction. If the impeller turns roughly, the bearings should be replaced (See Section F-6). If impeller hangs up or is hard to turn, the gap between the impeller and suction case should be checked. To check the gap, a feeler gauge should be used. Check the gap between the suction case liner and the impeller vanes as shown in Figure 7. Determine the proper gap setting from table 2 and adjust by adding or removing shims (17a) & (17b) behind the impeller.

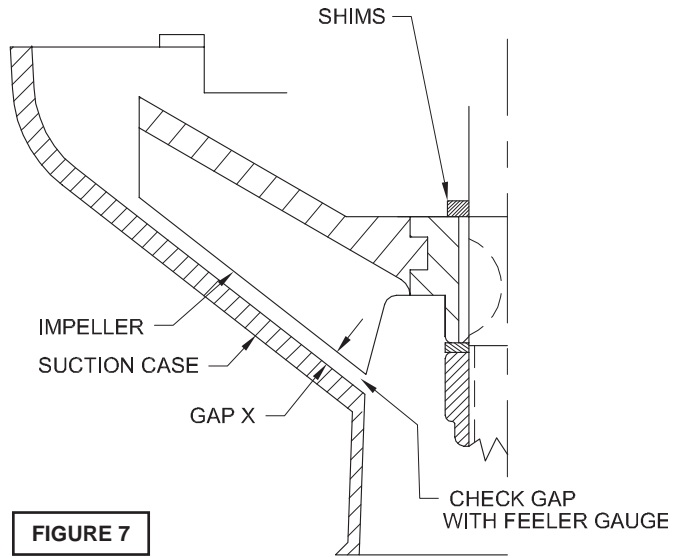

**FIGURE 7**

Inspect strainer (24) and clean, making sure hole are not clogged to ensure unrestricted flow. Now position strainer (24) onto suction case (4) and inserting three screws (40) in holes and tightening.

**F-4) Shaft Seal Service:**

**F-4.1) Disassembly:**

To replace outer shaft seal, drain oil per Section F-2.1 and remove impeller per Section F-3. Remove the shim washers (17a) & (17b), impeller key (15), seal retaining ring (48a) seal spring (48b), and seal rotating member (48c) from shaft, See Figure 8.

Examine all seal parts and specifically contact faces. Inspect seal for signs of uneven wear pattern on stationary members, chips and scratches on either seal face. DO NOT interchange seal components, replace the entire shaft seal (48). If replacing seal, remove screws (14) from seal retainer (12) and carefully pry the retainer (12) from diffuser (9) being careful not to damage diffuser (9) or o-ring (13), now remove retainer from the shaft. This will allow the removal of stationary (48d) by pushing out from back side of retainer or prying out with flat screw driver.

| TABLE 2 - IMPELLER GAP |              |              |
|------------------------|--------------|--------------|
| PUMP MODEL             | HP, 60 CYCLE | GAP "X"      |
| 9-20000                | 2.0          | .020 to .030 |
| 9-25000                | 2.5          | .020 to .030 |
| 9-35000                | 3.5          | .020 to .030 |
| 9-50000                | 5.0          | .020 to .030 |
| 9-55000                | 5.0          | .020 to .030 |

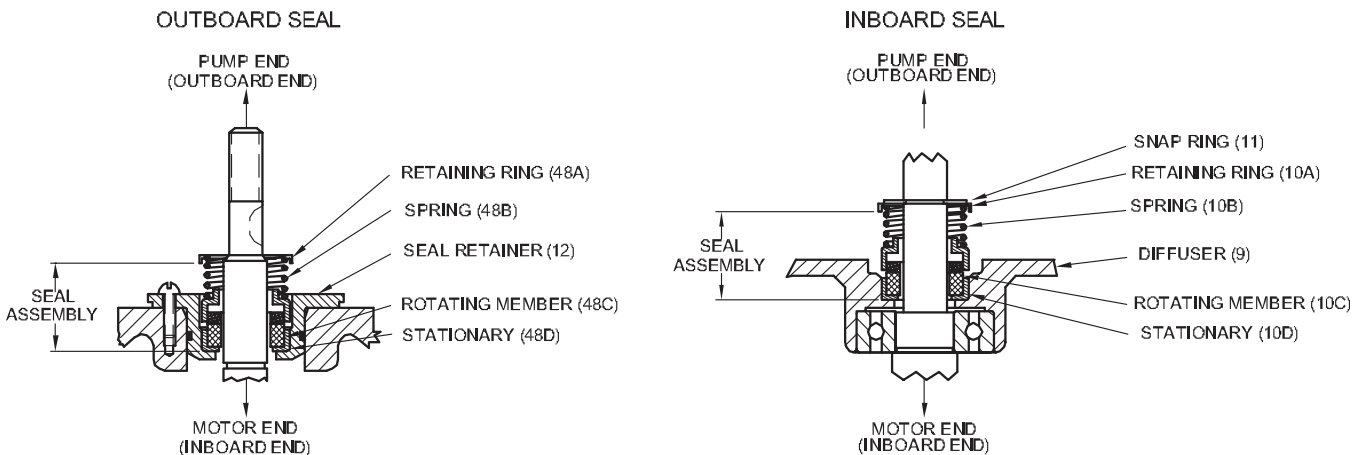

**FIGURE 8**

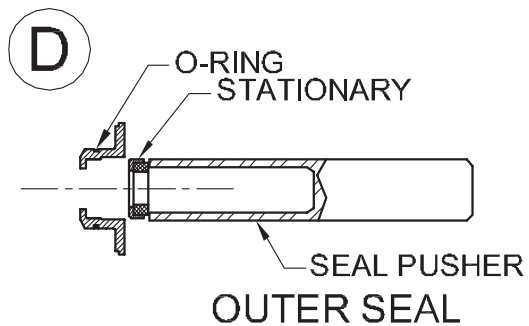
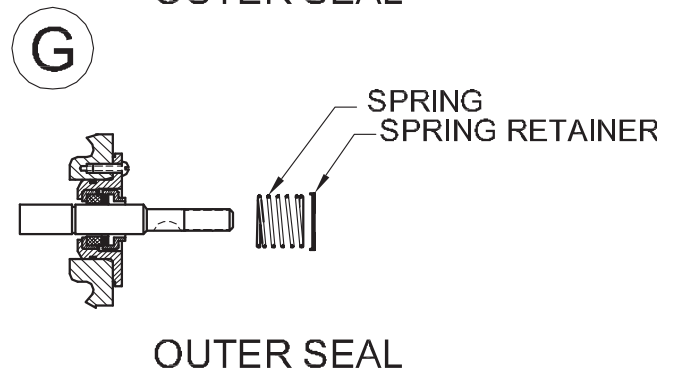
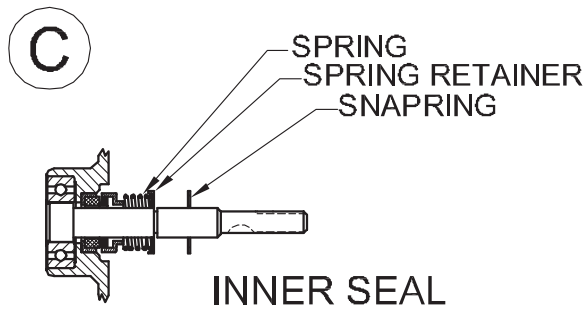
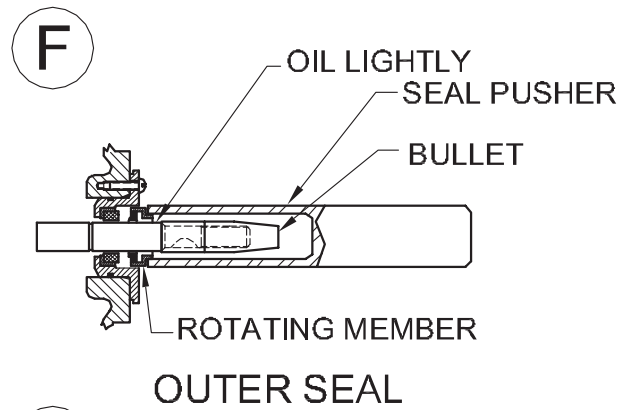
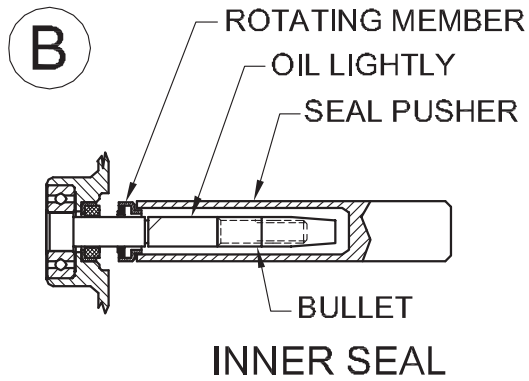
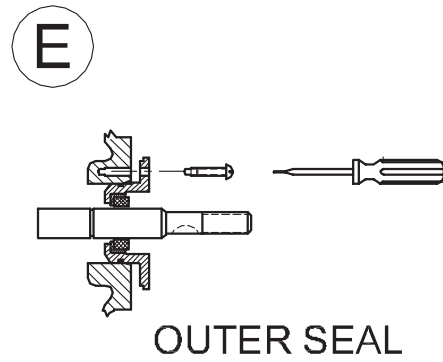
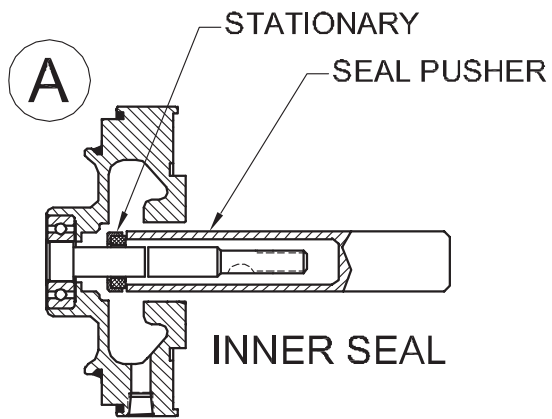

FIGURE 9

To remove inner shaft seal (10), remove snap ring (11), spring retainer (10a), and spring (10b) from shaft. The diffuser (9) and the rest of the inner seal (10) can now be removed by tapping the diffuser with a plastic hammer until free. Pull the lower end assembly from the stator/frame assembly, and check the rotor and stator for evidence of water, oil, electrical or mechanical damage. If damaged, replace rotor and stator/frame assembly, See section F-6.

**F-4.2) Reassembly:**

**Inner Seal** - Clean oil cavity in diffuser (9). Lightly oil (**DO NOT use grease**) outer surface of stationary member (10d). Press stationary member (10d) firmly into diffuser (9), using a seal pusher (see Parts List - seal tool kit). Nothing but the seal pusher is to come in contact with the seal face. Make sure the stationary member is in straight. (See Figure 9A).

**CAUTION ! - Handle seal parts with extreme care. DO NOT scratch or mar lapped surfaces.**

**IMPORTANT ! - DO NOT hammer on the seal pusher- it will damage the seal face.**

Slide a bullet (see parts list-seal tool kit) over motor shaft. Lightly oil (**DO NOT use grease**) shaft, bullet and inner surface of bellows on rotating member (10c). With lapped surface of rotating member (10c) facing inward toward stationary member (10d), slide rotating member (10c) over bullet and onto shaft, using seal pusher, until lapped faces of (10d) and (10c) are together (see Figure 9B).

**IMPORTANT ! - It is extremely important to keep seal faces clean during assembly. Dirt particles lodged between these faces will cause the seal to leak.**

Place spring (10b) over shaft and in place on rotating member (10c), making sure it is seated on retainer and not cocked or resting on bellows tail. Slide retaining ring (10a) over shaft and let rest on spring (10b). Replace snap ring (11) onto shaft. (See Figure 9C).

**Outer Seal** - Lightly oil (**DO NOT use grease**) outer surface of stationary member (48d). Press stationary member (48d) firmly into seal retainer (12), using a seal pusher (see Parts List - seal tool kit). Nothing but the seal pusher is to come in contact with the seal face. Make sure the stationary member is in straight, See Figure 9D. Lubricant O-ring (13) with a grease, and place it in the groove on seal retainer (12). Place seal retainer (12) into diffuser (9) and insert screws (14) and tighten, See Figure 9E. **NOTE:** When installing the seal retainer over shaft, do not scratch the shaft or seal seat face.

Slide a bullet (see parts list-seal tool kit) over motor shaft. Lightly oil (**DO NOT use grease**) shaft, bullet and inner surface of bellows on rotating member (48c). With lapped surface of rotating member (48c) facing inward toward stationary member (48d), slide rotating member (48c) over bullet and onto shaft, using seal pusher, until lapped faces of (48d) and (48c) are together (see Figure 9F). Place spring (48b) over shaft and in place on rotating member (48c), making sure it is seated on retainer and not cocked or resting on bellows tail. Slide retaining ring (48a) onto shaft and let rest on spring (48b), See Figure 9G. Assemble impeller, suction case and screen per Section F-3.2. Replace oil as outlined in paragraph F-2.2.

**F-5) Discharge & Cable Service:**

**F-5.1) Disassembly:**

Refer to Section F-1 before disassembly. While disassembling, check for indications of water leaks. Remove capscrews (28) and washers (30), cable gland assembly (2) and o-rings (25) from discharge head (22). Use care to avoid damaging the metal surface. Disconnect cable wires from stator leads by removing connectors (29), being sure that the stator's wires are identified before disconnecting. Check wires for breaks or cuts. If water is present, there may be leakage through the cable gland (2e), o-rings (19), (20), (25) and (50), the power cable (2a) if it has been cut, or the shaft seals (10) and (48). Check all items and replace if needed. Remove ground screw (33) and washer (39) from discharge head (22).

Remove capscrews (31), flat washers (49), lockwashers (55) and quad rings (56) from discharge head (22). Carefully, using a plastic hammer, tap the discharge case (22) free from the frame assembly and remove while feeding the stator wires through the terminal cavity and stator dam (47) in the discharge case. Now remove o-rings (19) and (20), replace o-rings showing any nicks, cuts, cracks, or deformation. To remove cable (2a), loosen cable grip nut (2b), cable grip (2c) and bushing (2d) and remove from cable. (See Figure 10).

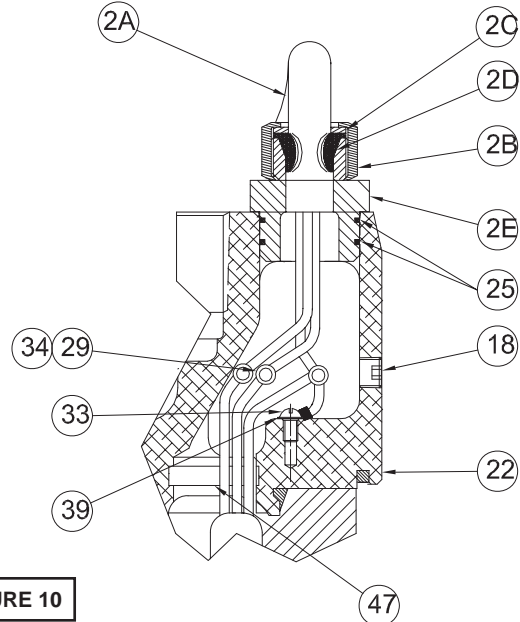
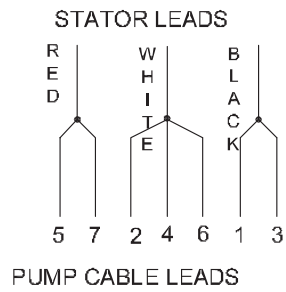

**FIGURE 10**

**F-5.2) Reassembly:**

To assemble discharge case (22) to stator/frame assembly, set the assembly in the upright position. Make sure all stator leads are properly identified (See Figure 11 or 12 for Dual Phase/ Voltage). Each lead should be color coded or numbered for identification. Apply a grease to o-rings (19) and (20) and place on discharge case (22). Set the discharge case (22) onto the stator/frame assembly with the terminal cavity directly over the stator leads and insert the leads through the stator dam (47) into cavity opening, being careful not to lose the lead identification numbers or damage the o-rings. Be sure that load spring (8) is sitting properly in bearing bore of discharge case. Line up the holes and insert capscrews (31) with flatwashers (49), lockwashers (55) and quad rings (56) into holes and torque to 75 In Lbs.

115 Volts Single Phase



230 Volts Single Phase

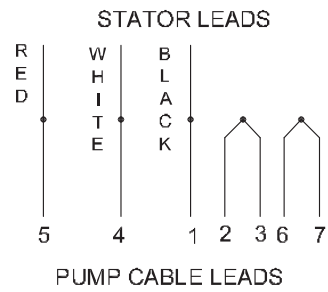

230 Volts Three Phase

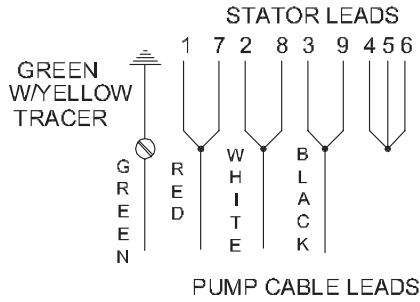

460 Volts Three Phase

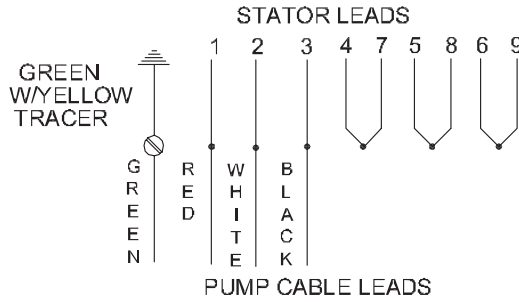

575 Volts Three Phase

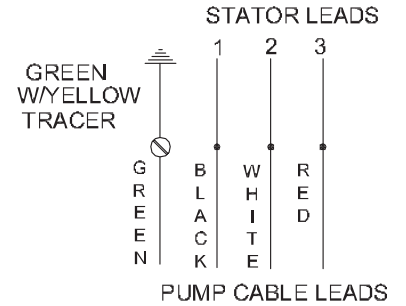

FIGURE 11

Figure 12A and 12B are for Dual Phase/Dual Voltage Pumps Models ONLY!

208-230 Volts  
Single & Three Phase

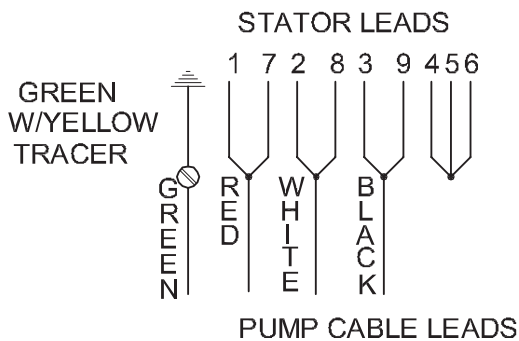

FIGURE 12A

460 Volts Three Phase

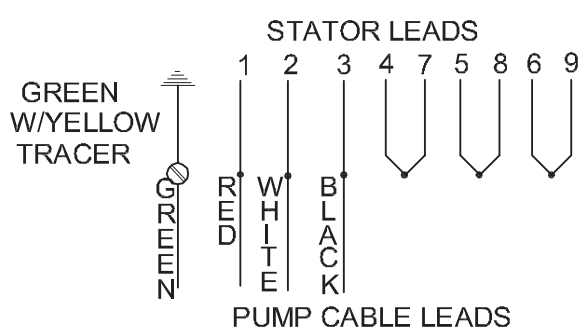

FIGURE 12B

Slide cable grip nut (2b), cable grip (2c), bushing (2d) and cable gland (2e) with o-rings (25) onto cable (2a), and expose approximately 3" of wire at the end of the cable. Attach ground screw (33) and washer (39) with ground wire (Green) to the inside of terminal cavity in discharge case (22). Make wire connections in accordance to Figures 11 or 12 using connectors (29) and then tape each connector individually with electrical tape. Fold and insert the connectors and wires into the terminal box cavity. Insert capscrews (28) with washers (30) and tighten to 5 Ft. Lbs.

Move Bushing (2d), cable grip (2c) and gland nut (2b) into place and tighten to 22 Ft. Lbs. After assembly, an insulation test (or MEGGER) should be performed per section F-1.1.

**F-5.3) Dual Phase/Dual Voltage Pump Models:**

The following changes must be done when converting phase and voltage to those pumps listed on page 5.

See chart on page 5 for the appropriate conversion kit before starting. This section, Table 3 and Figure 12 is for those models listed with an astric (\*), **ONLY !**

1. Replace existing impeller with impeller listed in Table 3 for appropriate conversion kit. See Section F-3 for disassembly and assembly.
2. Replace pump suction case with suction case listed in Table 3 for appropriate conversion kit. See Section F-3 for disassembly and assembly. Check gap per Section F-3.
3. Connect motor leads to cable in pump's terminal cavity. See Table 3, and Sections 5.1 & 5.2.
4. Replace control, listed in Table 3 for appropriate conversion kit, and connect pump & power cables to control. See Figure 21.
5. Check impeller rotation, must be clockwise as viewed from suction end. If not correct interchange the black and white pump cable wires connected to the circuit breaker in control box. See Section F-3.

**F-6) Motor and Bearing Service:**

**F-6.1) Disassembly:**

To service or replace motor and/or bearings, first remove discharge case (22) per Section F-5.1 and lower pump end per Section F-4.1. Remove rotor from stator, and bearings (7), (46), retaining rings (44), (53, 2-stage) Bearing ring (52, 2-stage) and loading spring (8) from rotor shaft. Use a bearing puller if needed. Bearings that feel rough, show wear or rust should be replaced. If stator needs replaced, replace stator and frame assembly.

**F-6.2) Reassembly:**

Set the stator/frame assembly and the discharge case in a vertical position with the discharge case down. Slip the outer case (21) over the frame (5). Press bearing (7) onto discharge end of rotor shaft. Place retaining ring (44) onto shaft and press bearing (46) with bearing ring (52, 2-stage) onto suction end of rotor shaft. Now assemble rotor assembly into stator/frame assembly. On 2-stage models, place retaining ring (53) into diffuser (9). Place o-rings (19) and (20), and bearing spring (8) onto discharge case (22). Assemble discharge case onto motor/frame assembly per Section F-5.2 and Pump lower end per Section F-4.2. An electrical inspection should be performed after reassembly per Section F-1.

**F-7 Motor Chamber Pressure Test:**

After final assembly, pressure test the motor chamber by removing pipe plug (18) from discharge case (22) and connect an air hose fitting into the pipe thread. Submerge the pump completely and apply 12 PSI air pressure. (See Figure 13)



**WARNING! - DO NOT exceed 12 psi air pressure.**

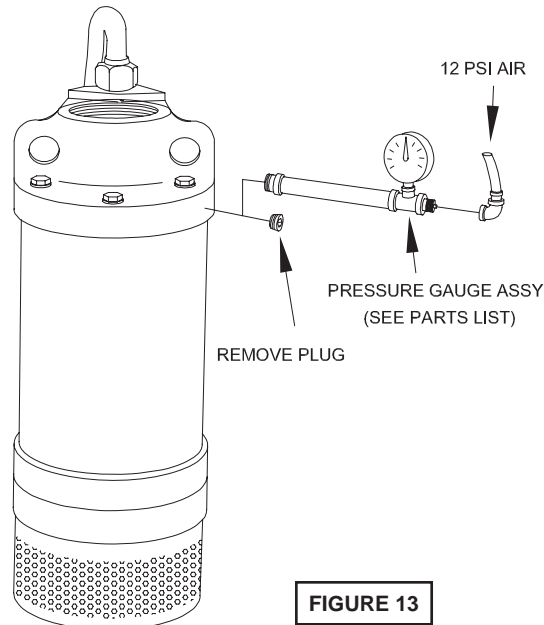

**FIGURE 13**

Pump must not show any leakage, if leakage occurs, determine location and replace defective or damaged parts, then retest pump. After pump has been tested and no leaks have been found, remove air hose connection and replace pipe plug (18) using a sealent, into discharge case (22).

| TABLE 3        |                                |                               |              |                  |             |                       |
|----------------|--------------------------------|-------------------------------|--------------|------------------|-------------|-----------------------|
| CONVERSION KIT | FROM                           | TO                            | IMPELLER P/N | SUCTION CASE P/N | CONTROL P/N | MOTOR LEAD CONNECTION |
| 9-500870-03    | 3Ph, 220/440V.<br>60Hz, 5HP    | 1Ph, 208-230V.<br>60Hz, 3.5HP | 9-350200-7   | 9-350100-1       | 9-350812-03 | Fig. 12A              |
| 9-500871-03    | 1Ph, 208-230V.<br>60Hz., 3.5HP | 3Ph, 208-230V.<br>60Hz., 5HP  | 9-500200-6   | 9-500100-1       | 9-810834-03 | Fig. 12A              |
| 9-500872-03    | 1Ph, 208-230V.<br>60Hz., 3.5HP | 3Ph, 460V.<br>60Hz., 5HP      | 9-500200-6   | 9-500100-1       | 9-500834-03 | Fig. 12B              |



**SECTION: G REPLACEMENT PARTS**

**G-1 ORDERING REPLACEMENT PARTS:**

Your local Prosser distributor can supply parts and repair service. When ordering parts, ALWAYS furnish the following information: Specify pump model number as shown on nameplate, serial number, part number, item number and part name.

1. Pump serial number. (G-1)
2. Pump model number. (G-2)
4. Part description.
5. Item part number.
6. Quantity required.
7. Shipping instructions.
8. Billing Instructions.

**G-1 SERIAL NUMBER:**

The Serial Number block will consists of a six digit number, which is specific to each pump and may be preceded by a alpha character, which indicates the plant location. This number will also be suffixed with a three or four digit number, which indicates the date the unit was built (Date Code).

EXAMPLE: A012345 495

Reference the six digit portion (Serial Number) of the number when referring to the product.

**G-2 MODEL NUMBER:**

This designation consist of numbers which represent, Pump Line, Horsepower, Motor phase, Voltage and Variations (as shown below). This Number is used for ordering and obtaining information.

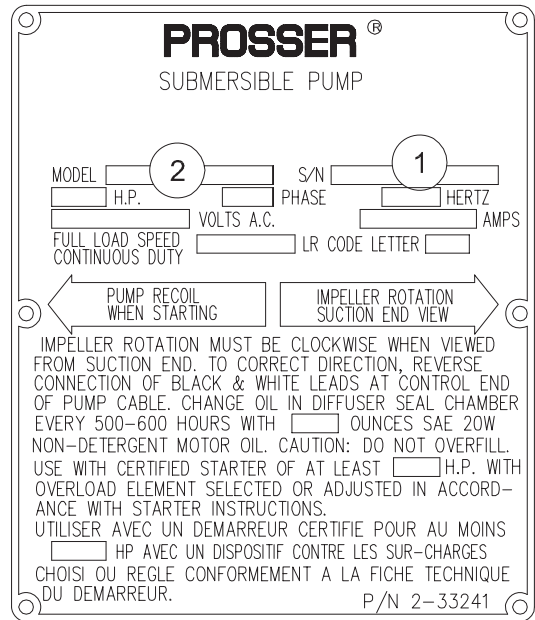

**MODEL NUMBER DESIGNATION**

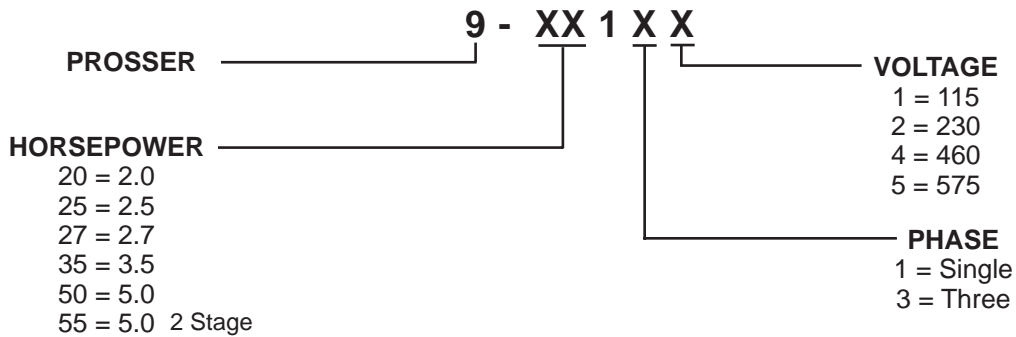

## TROUBLE SHOOTING

CAUTION ! Always disconnect the pump from the electrical power source before handling.  
 If the system fails to operate properly, carefully read instructions and perform maintenance recommendations.  
 If operating problems persist, the following chart may be of assistance in identifying and correcting them:  
 MATCH "CAUSE" NUMBER WITH CORRELATING "CORRECTION" NUMBER.

NOTE: Not all problems and corrections will apply to each pump model.

| PROBLEM  | CAUSE   | CORRECTION   |
|--|---|--|
| Pump will not run  | <ol style="list-style-type: none"> <li>1. Poor electrical connection, blown fuse, tripped breaker or other interruption of power, improper power supply.</li> <li>2. Motor or switch inoperative (to isolate cause, go to manual operation of pump).                             <ol style="list-style-type: none"> <li>2a. Float movement restricted.</li> <li>2b. Switch will not activate pump or is defective.</li> <li>2c. Defective motor</li> </ol> </li> <li>3. Insufficient liquid level.</li> </ol> | <ol style="list-style-type: none"> <li>1. Check all electrical connections for security. Have electrician measure current in motor leads, if current is within <math>\pm 20\%</math> of locked rotor Amps, impeller is probably locked. If current is 0, overload may be tripped. Remove power, allow pump to cool, then recheck current.</li> <li>2a. Reposition pump or clean basin as required to provide adequate clearance for float.</li> </ol>  |
| Pump will not turn off   | <ol style="list-style-type: none"> <li>2a. Float movement restricted.</li> <li>2b. Switch will not activate pump or is defective.</li> <li>4. Excessive inflow or pump not properly sized for application.</li> <li>9. Pump may be airlocked</li> <li>14. H-O-A switch on panel is in "HAND" position</li> </ol>  | <ol style="list-style-type: none"> <li>2b. Disconnect level control. Set ohmmeter for a low range, such as 100 ohms full scale and connect to level control leads. Actuate level control manually and check to see that ohmmeter shows zero ohms for closed switch and full scale for open switch. (Float Switch).</li> <li>2c. Check winding insulation (Megger Test) and winding resistance. If check is outside of range, dry and recheck. If still defective, replace per service instructions.</li> </ol> |
| Pump hums but does not run   | <ol style="list-style-type: none"> <li>1. Incorrect voltage</li> <li>8. Impeller jammed or loose on shaft, worn or damaged, impeller cavity or inlet plugged.</li> </ol>  | <ol style="list-style-type: none"> <li>2c. Check winding insulation (Megger Test) and winding resistance. If check is outside of range, dry and recheck. If still defective, replace per service instructions.</li> </ol>  |
| Pump delivers insufficient capacity  | <ol style="list-style-type: none"> <li>1. Incorrect voltage.</li> <li>4. Excessive inflow or pump not properly sized for application.</li> <li>5. Discharge restricted.</li> <li>6. Check valve stuck closed or installed backwards.</li> <li>7. Shut-off valve closed.</li> <li>8. Impeller jammed or loose on shaft, worn or damaged, impeller cavity or inlet plugged.</li> <li>9. Pump may be airlocked.</li> <li>10. Pump running backwards</li> </ol>   | <ol style="list-style-type: none"> <li>3. Make sure liquid level is at least equal to suggested turn-on point.</li> <li>4. Recheck all sizing calculations to determine proper pump size.</li> <li>5. Check discharge line for restrictions, including ice if line passes through or into cold areas.</li> <li>6. Remove and examine check valve for proper installation and freedom of operation.</li> <li>7. Open valve.</li> </ol>  |
| Pump cycles too frequently or runs periodically when fixtures are not in use   | <ol style="list-style-type: none"> <li>6. Check valve stuck closed or installed backwards.</li> <li>11. Fixtures are leaking.</li> <li>15. Ground water entering basin.</li> </ol>  | <ol style="list-style-type: none"> <li>8. Check impeller for freedom of operation, security and condition. Clean impeller and inlet of any obstruction.</li> <li>9. Loosen union slightly to allow trapped air to escape. Verify that turn-off level of switch is set so that the suction is always flooded. Clean vent hole.</li> </ol>   |
| Pump shuts off and turns on independent of switch, (trips thermal overload protector). <b>CAUTION!</b> Pump may start unexpectedly. Disconnect power supply.<br><br><b>NOTE:</b> Some pumps <b>DO NOT</b> have thermal overload protection on the motor. Check pump specifications to determine. | <ol style="list-style-type: none"> <li>1. Incorrect voltage.</li> <li>4. Excessive inflow or pump not properly sized for application.</li> <li>8. Impeller jammed, loose on shaft, worn or damaged, impeller cavity or inlet plugged.</li> <li>12. Excessive water temperature. (internal protection only)</li> </ol>   | <ol style="list-style-type: none"> <li>10. Check rotation. If power supply is three phase, reverse any two of three power supply leads to ensure proper impeller rotation..</li> <li>11. Repair fixtures as required to eliminate leakage.</li> </ol>  |
| Pump operates noisily or vibrates excessively  | <ol style="list-style-type: none"> <li>2c. Worn bearings, motor shaft bent.</li> <li>5. Debris in impeller cavity or broken impeller</li> <li>10. Pump running backwards</li> <li>13. Piping attachments to building structure too rigid or too loose.</li> </ol>   | <ol style="list-style-type: none"> <li>12. Check pump temperature limits &amp; fluid temperature.</li> <li>13. Replace portion of discharge pipe with flexible connector.</li> <li>14. Turn to automatic position.</li> <li>15. Check for leaks around basin inlet and outlets.</li> </ol>   |

PUMP SERIES: 9-20000, 9-25000, 9-27000, 9-35000 & 9-50000

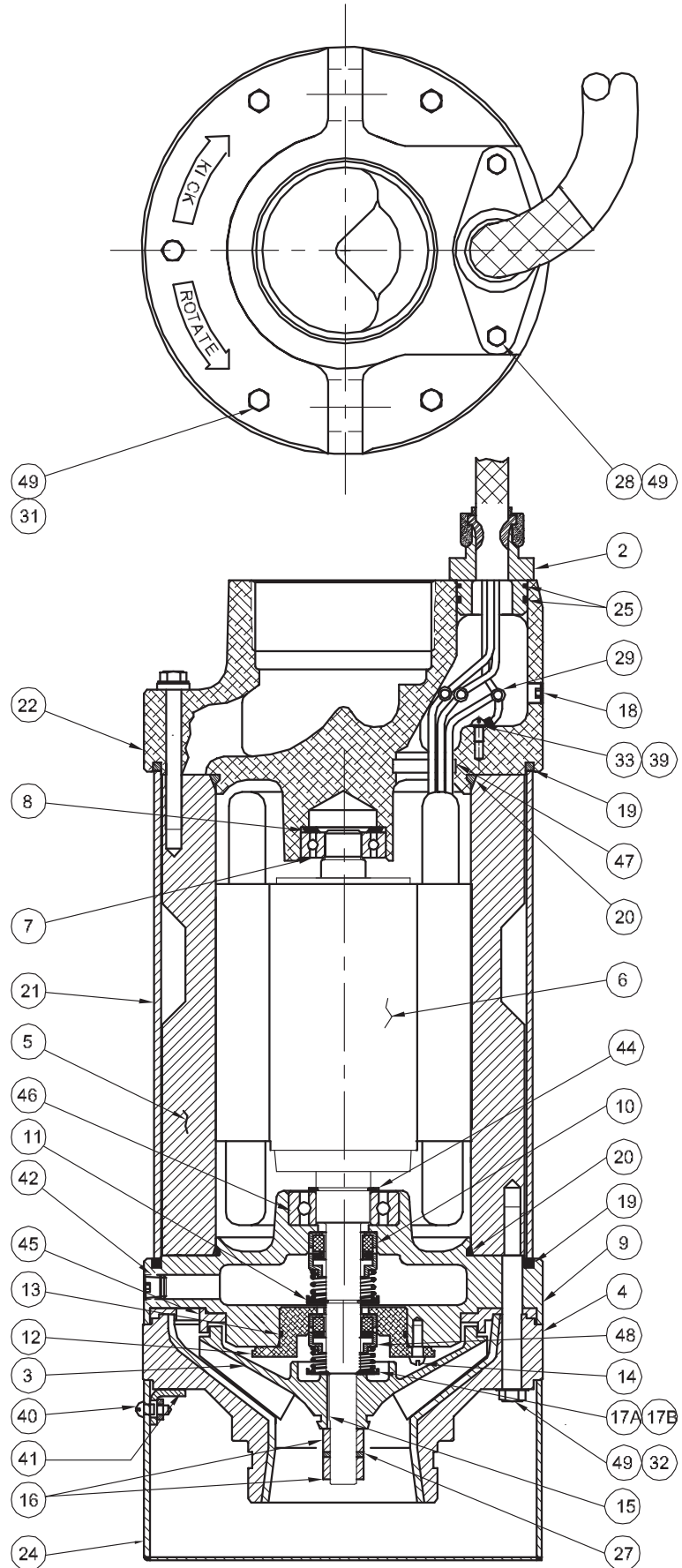

FIGURE 14

# PUMP SERIES: 9-20000, 9-25000, 9-27000, 9-35000 & 9-50000

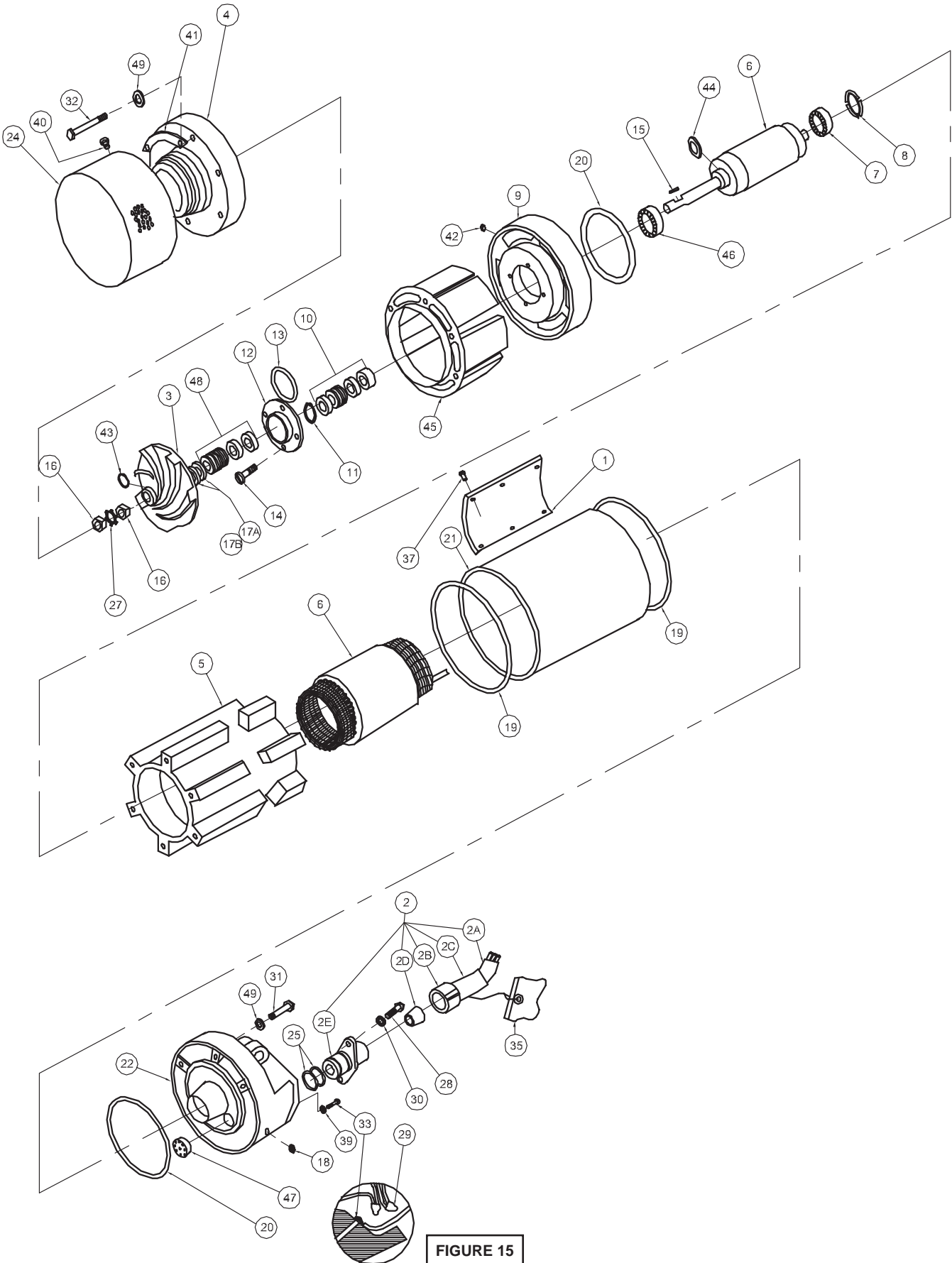

FIGURE 15

# PUMP SERIES: 9-20000, 9-25000, 9-27000, 9-35000 & 9-50000

## PARTS KITS

**Bearing & Seal Kit ..... P/N- 9-500580 (+) 7, 8, 10, 11, 13, 15, 16, 17a, 17b, 27, 43, 46, 48**

**O-Ring Kit..... P/N- 9-500574 (◆) 2d, 13, 19, 20, 25, 29, 43**

**Seal Tool Kit..... TL - 21355 Contact Parts Dept.**

## CONVERSION KITS

**Pump Model 9-25000 High Head to High Volume ..... P/N: 9-250180**

**Pump Model 9-25000 High Volume to High Head ..... P/N: 9-250185**

## PARTS LIST

| ITEM | QTY | PART NO.    | DESCRIPTION   |
|------|-----|-------------|---|
| 1    | 1   | 2-33241     | Name Plate  |
| 2    | 1   | 9-500710-2  | Cable & Gland Assy  |
| 2a   | 1   | 9-350887-50 | * Cable, 50 ft.   |
| 2b   | 1   | 2-12062     | * Cable Grip Nut                      Stainless Steel                         |
| 2c   | 1   | 2-12020-2A  | * Cable Grip                            Alodined                              |
| 2d   | 1   | 2-12022-2   | *◆ Bushing                              Neoprene                              |
| 2e   | 1   | 9-500711-1  | * Cable Gland                          Aluminum                               |
| 3    | 1   | 9-200200-6  | Impeller, Stainless                5.31" Dia                2HP               |
|      | 1   | 9-250200-6  | Impeller, Stainless                5.31" Dia.               2.5HP-HH          |
|      | 1   | 9-275200-2  | Impeller, Stainless                4.25" Dia.               2.5HP-HV & 2.75HP |
|      | 1   | 9-350200-7  | Impeller, Stainless                5.22" Dia.               3.5HP             |
|      | 1   | 9-500200-6  | Impeller, Stainless                5.31" Dia.               5HP               |
| 4    | 1   | 9-250100-1  | Suction Case                        2HP, 2.5HP-HH                             |
|      | 1   | 9-500100-1  | Suction Case                        2.5HP-HV, 2.75HP & 5HP                    |
|      | 1   | 9-350100-1  | Suction Case                        3.5HP                                     |
| 5    | 1   | 9-250500    | Frame                                 2HP, 2.5HP                              |
|      | 1   | 9-500500    | Frame                                 3.5HP, 5HP                              |
| 6    | 1   | 9-250400    | Rotor                                 2HP, 115/208-230V, 1Ph                  |
|      | 1   | 9-200600    | Stator                                 2HP, 115/208-230V, 1Ph                 |
|      | 1   | 9-250400    | Rotor                                 2.5HP, 230V, 3Ph                        |
|      | 1   | 9-250600    | Stator                                 2.5HP, 230V, 3Ph                       |
|      | 1   | 9-250400    | Rotor                                 2.5HP, 460V, 3Ph                        |
|      | 1   | 9-250600    | Stator                                 2.5HP, 460V, 3Ph                       |
|      | 1   | 9-250400    | Rotor                                 2.5HP, 575V, 3Ph                        |
|      | 1   | 9-250635    | Stator                                 2.5HP, 575V, 3Ph                       |
|      | 1   | 9-250400    | Rotor                                 2.75HP, 115/208-230V, 1Ph               |
|      | 1   | 9-200600    | Stator                                 2.75HP, 115/208-230V, 1Ph              |
|      | 1   | 9-500400    | Rotor                                 3.5HP, 230V, 1Ph                        |
|      | 1   | 9-350612    | Stator                                 3.5HP, 230V, 1Ph                       |
|      | 1   | 9-500400    | Rotor                                 5HP, 230V, 3Ph                          |
|      | 1   | 9-500600    | Stator                                 5HP, 230V, 3Ph                         |
|      | 1   | 9-500400    | Rotor                                 5HP, 460V, 3Ph                          |
|      | 1   | 9-500600    | Stator                                 5HP, 460V, 3Ph                         |
|      | 1   | 9-500400    | Rotor                                 5HP, 575V, 3Ph                          |
|      | 1   | 9-500635    | Stator                                 5HP, 575V, 3Ph                         |
| 7    | 1   | 112543      | + Bearing   |
| 8    | 2   | 2-30001     | + Bearing Loading Spring  |
| 9    | 1   | 9-500300-2  | Diffuser  |
| 10   | 1   | 2-31001     | + Shaft Seal, Inboard                Carbon/Ceramic/Buna-N                    |

(\*) Included with item number 2.

## PUMP SERIES: 9-20000, 9-25000, 9-27000, 9-35000 & 9-50000

|     |     |             |    |                                    |  |
|-----|-----|-------------|----|------------------------------------|--|
| 11  | 1   | 2-27004-59  |    | Snap Ring                          |  |
| 12  | 1   | 9-500311    |    | Seal Retainer                      |  |
| 13  | 1   | 2-31003-035 | +◆ | O-Ring                             |  |
| 14  | 2   | 2-22003-41  |    | Rd. Hd. Screw                      | 10-24 x .50"Lg.                                    |
| 15  | 1   | 9-500407    | +  | Key                                | .093" x .13 x .688"                                |
| 16  | 2   | 2-20002-38  | +  | Lock Nut, Impeller                 | 1/2-20, Stainless                                  |
| 17a | A/R | 2-21010-1   | +  | Shim, .016 Thk                     |  |
| 17b | A/R | 2-21010-2   | +  | Shim, .032 Thk.                    |  |
| 18  | 1   | 2-32004-8   |    | Pipe Plug                          | .125" NPT, Stainless                               |
| 19  | 2   | 2-31003-260 | ◆  | O-Ring                             |  |
| 20  | 2   | 2-31003-246 | ◆  | O-Ring                             |  |
| 21  | 1   | 9-250555    |    | Outer Shell                        | 2, 2.5 & 2.75HP                                    |
|     | 1   | 9-500555    |    | Outer Shell                        | 3.5HP, 5HP   |
| 22  | 1   | 9-250700    |    | Discharge Head (Includes 9-250702) | 2 & 2.5HP  |
|     | 1   | 9-500700    |    | Discharge Head                     | 2.75, 3.5HP & 5HP                                  |
| 24  | 1   | 9-500000-1  |    | Strainer                           | Stainless Steel                                    |
| 25  | 2   | 2-31003-025 | ◆  | O-ring                             |  |
| 27  | 1   | 9-500210    | +  | Lockwasher, Impeller               | .442 x 1.092, Stainless                            |
| 28  | 2   | 1-6-1       |    | Hex Hd Screw                       | 1/4-20 x .875"Lg, Stainless                        |
| 29  | 2   | 2-12026-1   | ◆  | Connector                          | 1 Phase  |
|     | 3   | 2-12026-2   |    | Connector                          | 3 Phase  |
| 30  | 2   | 086538      |    | Flat Washer                        | 1/4 Stainless                                      |
| 31  | 5   | 1-159-1     |    | Hex Hd Screw                       | 5/16-18 x 2.25"Lg., Stainless                      |
| 32  | 6   | 1-168-1     |    | Hex Hd Screw                       | 5/16-18 x 3.50"Lg., Stainless                      |
| 33  | 1   | 2-86-7      |    | Rd. Hd. Screw                      | 10-32 x 1/4"Lg., Brass                             |
| 35  | 1   | 2-33012     |    | Tag, Lead, Ground                  |  |
| 37  | 6   | 2-28002-3   |    | Rivet                              |  |
| 38  | 5oz | A3195AB     |    | Oil, Navy                          |  |
| 39  | 1   | 21-10-3     |    | Lockwasher                         | #10 Steel  |
| 40  | 3   | 2-23010-54  |    | Pan Hd Screw                       | 1/2-20 x .50"Lg. CadPltd.                          |
| 41  | 3   | 9-500003    |    | Bracket                            |  |
| 42  | 1   | 2-32004-12  |    | Pipe Plug                          | .25" NPT Stainless                                 |
| 43  | 1   | 2-31003-117 | +◆ | O-Ring                             |  |
| 44  | 1   | 2-27004-98  |    | Retaining Ring                     |  |
| 45  | 1   | 9-501305    |    | Wear Plate, Polyurethane           |  |
| 46  | 1   | 112544      | +  | Bearing                            |  |
| 47  | 1   |             |    | Stator Dam:                        |  |
|     |     | 9-500750-2  |    |                                    | 2HP, 115/1, 2HP, 230/1, 2.75HP, 230/1              |
|     |     | 9-500750    |    |                                    | 2.5HP, 230/3, 2.5HP, 460/3, 5HP, 230/3, 5HP, 460/3 |
|     |     | 9-500750-1  |    |                                    | 2.5HP, 575/3, 3.5HP, 230/1, 5HP, 575/3             |
| 48  | 1   | 9-500350    | +  | Shaft Seal, Outboard               | Silicon/Silicon/Viton®                             |
| 49  | 11  | 20-21-1     |    | Flat Washer                        | 5/16 Stainless                                     |

# PUMP SERIES: 9-55000 (2-Stage)

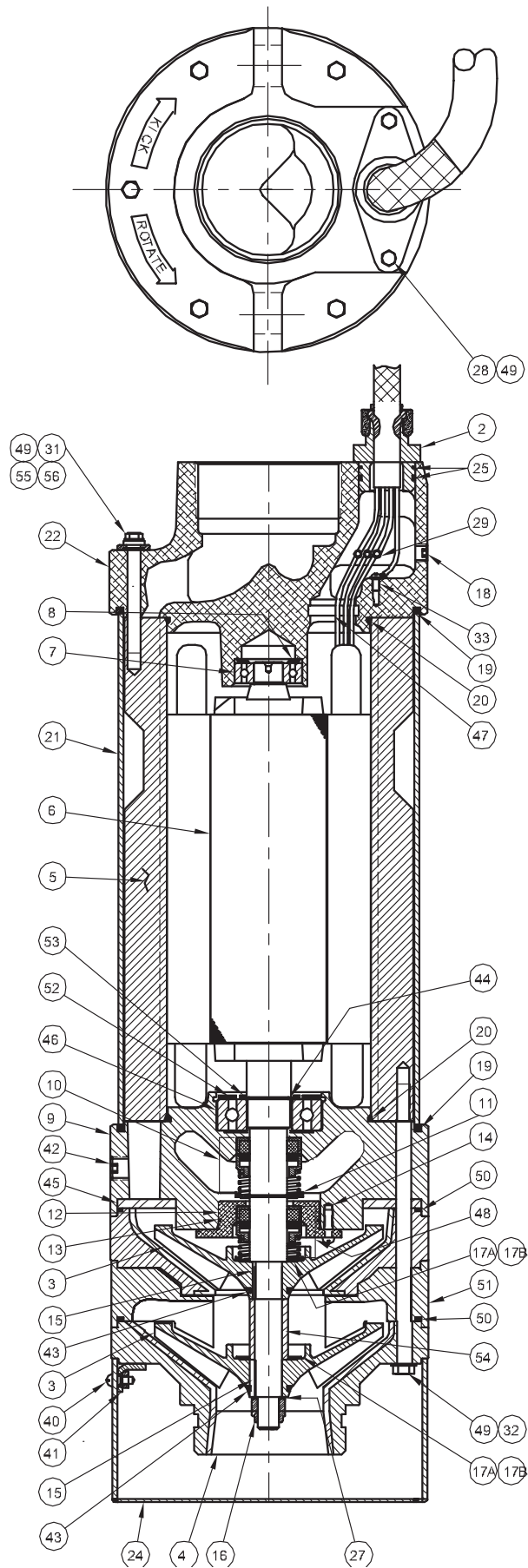

FIGURE 16

# PUMP SERIES: 9-55000 (2-Stage)

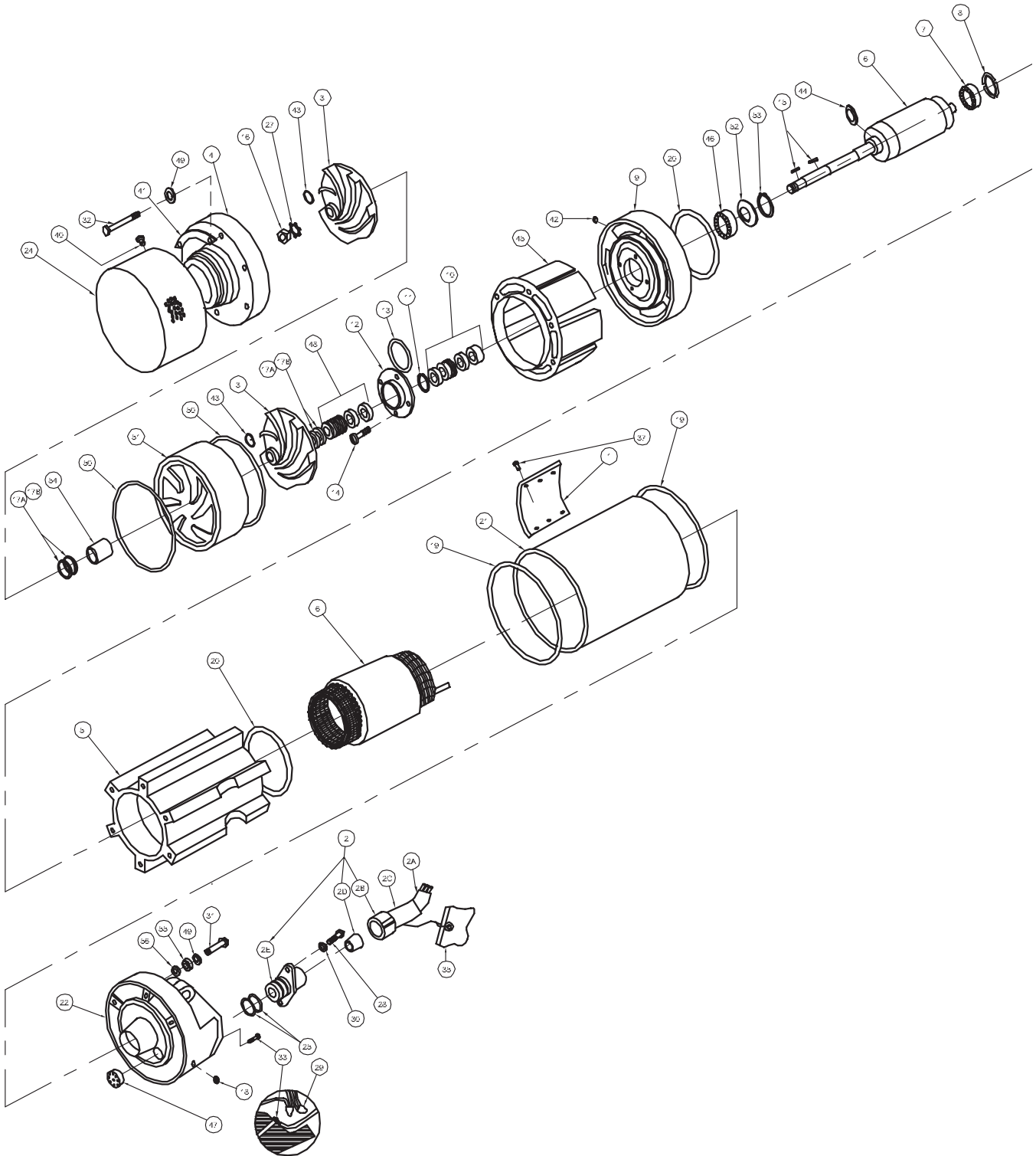

FIGURE 17



# PUMP SERIES: 9-55000 (2-Stage)

## PARTS KITS

**Bearing & Seal Kit ..... P/N- 9-550580** (+) 7, 8, 10, 11, 13, 15, 16, 17a, 17b, 27, 43, 46, 48

**O-Ring Kit..... P/N- 9-500574** (◆) 2d, 13,19, 20, 25, 29, 43

**Seal Tool Kit, 9-55000.....TL - 21357 Contact Parts Dept.**

## PARTS LIST

| ITEM | QTY | PART NO.    | DESCRIPTION              |                           |
|------|-----|-------------|--------------------------|---------------------------|
| 1    | 1   | 2-33241     | Name Plate               |                           |
| 2    | 1   | 9-500710-2  | Cable & Gland Assy       |                           |
| 2a   | 1   | 9-350887-50 | * Cable, 50 ft.          |                           |
| 2b   | 1   | 2-12062     | * Cable Grip Nut         | Stainless Steel           |
| 2c   | 1   | 2-12020-2A  | * Cable Grip             | Alodined                  |
| 2d   | 1   | 2-12022-2   | *◆ Bushing               | Neoprene                  |
| 2e   | 1   | 9-500711-1  | * Cable Gland            | Aluminum                  |
| 3    | 1   | 9-550200-2  | Impeller, Stainless      | 5.31" Dia                 |
| 4    | 1   | 9-550100    | Suction Case             |                           |
| 5    | 1   | 9-500500    | Frame                    |                           |
| 6    | 1   | 9-550400    | Rotor                    | 5HP, 230V, 3PH            |
|      | 1   | 9-500600    | Statot                   | 5HP, 230V, 3PH            |
|      | 1   | 9-550400    | Rotor                    | 5HP, 460V, 3PH            |
|      | 1   | 9-500600    | Stator                   | 5HP, 460V, 3PH            |
|      | 1   | 9-550400    | Rotor                    | 5HP, 575V, 3PH            |
|      | 1   | 9-500635    | Stator                   | 5HP, 575V, 3PH            |
| 7    | 1   | 112543      | + Bearing                |                           |
| 8    | 1   | 2-30002-6   | + Bearing Loading Spring |                           |
| 9    | 1   | 9-550300-2  | Diffuser                 |                           |
| 10   | 1   | 2-31006     | + Shaft Seal, Inboard    | Carbon/Ceramic/Buna-N     |
| 11   | 1   | 2-27002-87  | + Snap Ring              |                           |
| 12   | 1   | 9-815310    | Seal Retainer            |                           |
| 13   | 1   | 2-31003-035 | +◆ O-Ring                |                           |
| 14   | 4   | 2-22003-41  | Rd. Hd. Screw            | 10-24 x .50"Lg.           |
| 15   | 2   | 9-500407    | + Key                    | .093" x .13 x .688"       |
| 16   | 1   | 2-20002-43  | + Lock Nut, Impeller     | 5/8-18, Stainless         |
| 17a  | A/R | 9-815210-1  | + Shim, .016 Thk         |                           |
| 17b  | A/R | 9-815210-2  | + Shim, .032 Thk.        |                           |
| 18   | 1   | 2-32004-8   | Pipe Plug                | .125" NPT, Stainless      |
| 19   | 2   | 2-31003-260 | ◆ O-Ring                 |                           |
| 20   | 2   | 2-31003-246 | ◆ O-Ring                 |                           |
| 21   | 1   | 9-500555    | Outer Shell              |                           |
| 22   | 1   | 9-250700    | Discharge Head           |                           |
| 24   | 1   | 9-500000-1  | Strainer                 | Stainless Steel           |
| 25   | 2   | 2-31003-025 | ◆ O-ring                 |                           |
| 27   | 1   | 9-550211    | + Lockwasher, Impeller   | .63 x 1.436, Stainless    |
| 28   | 2   | 2-23012-40  | Capscrew                 | 1/4-20 x .875"Lg, Zp      |
| 29   | 2   | 2-12026-1   | ◆ Connector              | 1 Phase                   |
|      | 6   | 2-12026-1   | Connector                | 3 Phase                   |
| 30   | 2   | 2-21002-11  | Flat Washer              | 1/4 Zp                    |
| 31   | 5   | 2-23002-11  | Capscrew                 | 5/16-18 x 2.50"Lg., Pass  |
| 32   | 6   | 2-23013-128 | Capscrew                 | 5/16-18 x 6.50"Lg., Zp    |
| 33   | 1   | 2-86-7      | Rd. Hd. Screw            | 10-32 x 1/4"Lg., Brass    |
| 35   | 1   | 2-33012     | Tag, Lead, Ground        |                           |
| 37   | 6   | 2-28002-3   | Rivet                    |                           |
| 38   | 6oz | A3195AB     | Oil, Navy                |                           |
| 40   | 3   | 2-23010-54  | Pan Hd Screw             | 1/2-20 x .50"Lg. CadPltd. |
| 41   | 3   | 9-500003    | Bracket                  |                           |
| 42   | 1   | 2-32004-12  | Pipe Plug                | .25" NPT Stainless        |
| 43   | 2   | 2-31003-117 | +◆ O-Ring                |                           |

(\* ) Included with item number 2.

## PUMP SERIES: 9-82500, 9-85000

|    |    |             |                          |                        |
|----|----|-------------|--------------------------|------------------------|
| 44 | 1  | 2-27004-98  | Retaining Ring           |                        |
| 45 | 1  | 9-501306    | Wear Plate, Polyurethane |                        |
| 46 | 1  | 112546      | + Bearing, Ball          |                        |
| 47 | 1  | 9-500750    | Stator Dam               |                        |
|    | 1  | 9-500750-1  | Stator Dam               | 575 Volt ONLY          |
| 48 | 1  | 9-815350    | + Shaft Seal, Outboard   | Silicon/Silicon/Viton® |
| 49 | 11 | 2-21002-14  | Flat Washer              | 5/16 Zp                |
| 50 | 2  | 2-31003-166 | O-Ring                   |                        |
| 51 | 1  | 9-550303    | Diffuser, Lower          |                        |
| 52 | 1  | 2-30009-4   | Nilos Bearing Ring       |                        |
| 53 | 1  | 2-27006-244 | Retaining Ring           |                        |
| 54 | 1  | 9-550209    | Spacer                   |                        |
| 55 | 1  | 9-605012    | Lockwasher               | .328 x .750            |
| 56 | 5  | 2-31009-011 | Quad Ring                |                        |

## NEMA 3R (RainProof)

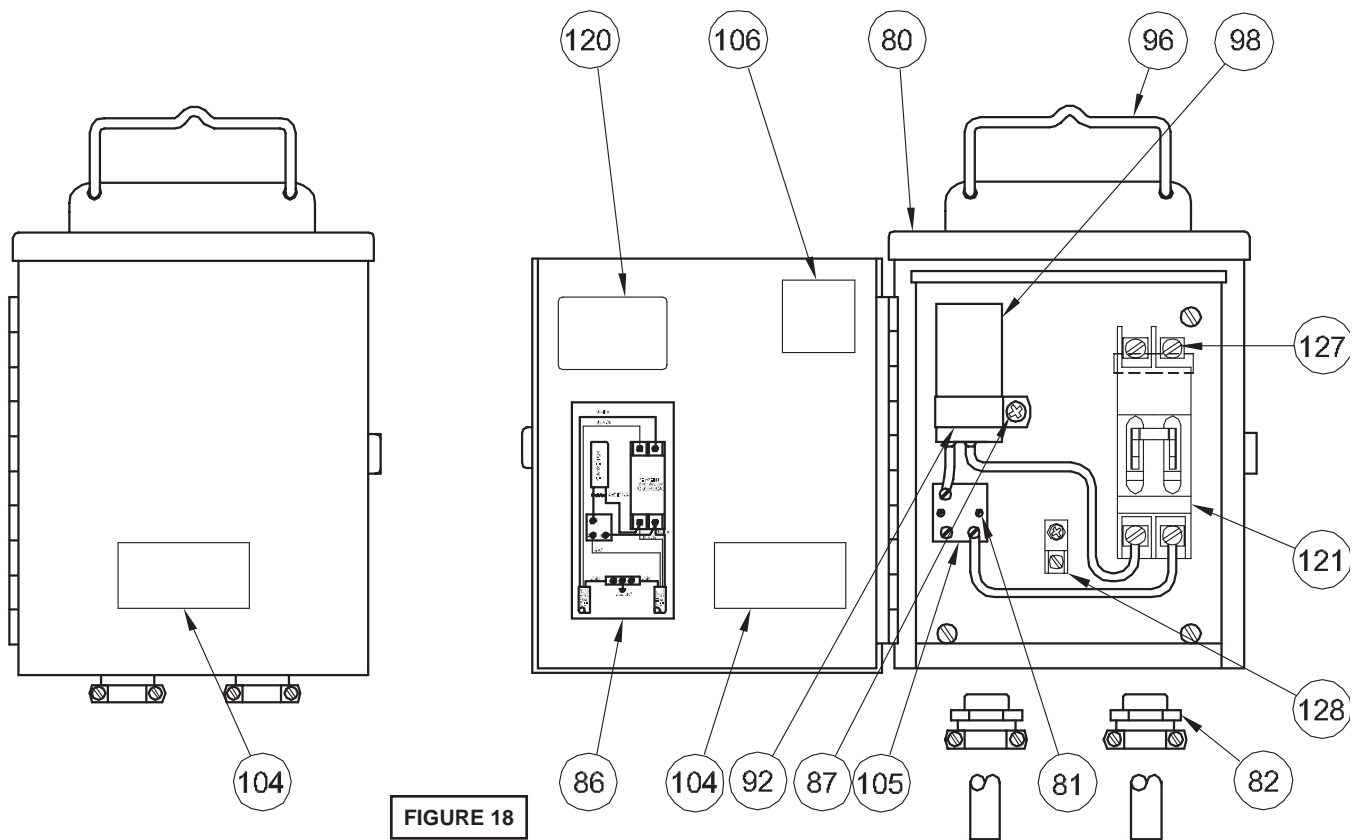

FIGURE 18

### PARTS LIST

| ITEM | QTY | PART NO.    | DESCRIPTION                           |
|------|-----|-------------|---------------------------------------|
| 80.  | 1   | 9-840814    | Enclosure, NEMA 3R                    |
| 81.  | 4   | 2-22002-10  | Screw 6-32 x .312"Lg.                 |
| 82.  | 2   | 2-12005-2   | Connector .75"                        |
| 86.  | 1   | 2-33064     | Connection Diagram 115/230V., 1 Phase |
|      | 1   | 2-33065     | Connection Diagram 3 Phase            |
| 87.  | 7   | 2-22009-16  | Screw 8-32 x .50"Lg                   |
| 91.  | 1   | SEE TABLE 4 | Capacitor, Run                        |
| 92.  | 1   | 2-12019-3   | Clamp, Capacitor                      |
| 96.  | 1   | 9-100803    | Handle                                |
| 98.  | 1   | SEE TABLE 4 | Capacitor, Start,                     |
| 99.  | 1   | 2-12019-1   | Clamp                                 |
| 104. | 2   | 2-33063     | Name Plate 1 Phase                    |
| 105. | 1   | 9-200853-1  | Relay, 1Ph 115V.                      |
|      | 1   | 9-350853-1  | Relay, 1Ph 230V.                      |
| 106. | 1   | 085809      | Label, CSA                            |
| 108. | 1   | 2-12012-2   | Terminal, Disconnect (Not Shown), 1Ph |
| 120. | 1   | 2-33016     | Caution Label                         |
| 121. | 1   | SEE TABLE 4 | Circuit Breaker                       |
| 125. | 1   | 2-33011     | Label (Not Shown)                     |
| 127. | 1   | 2-28014     | Mounting Bracket                      |
| 128. | 1   | 086135      | Ground Lug                            |
|      | 1   | 086335      | Ground Lug 5HP ONLY                   |

## NEMA 4 (WaterTight)

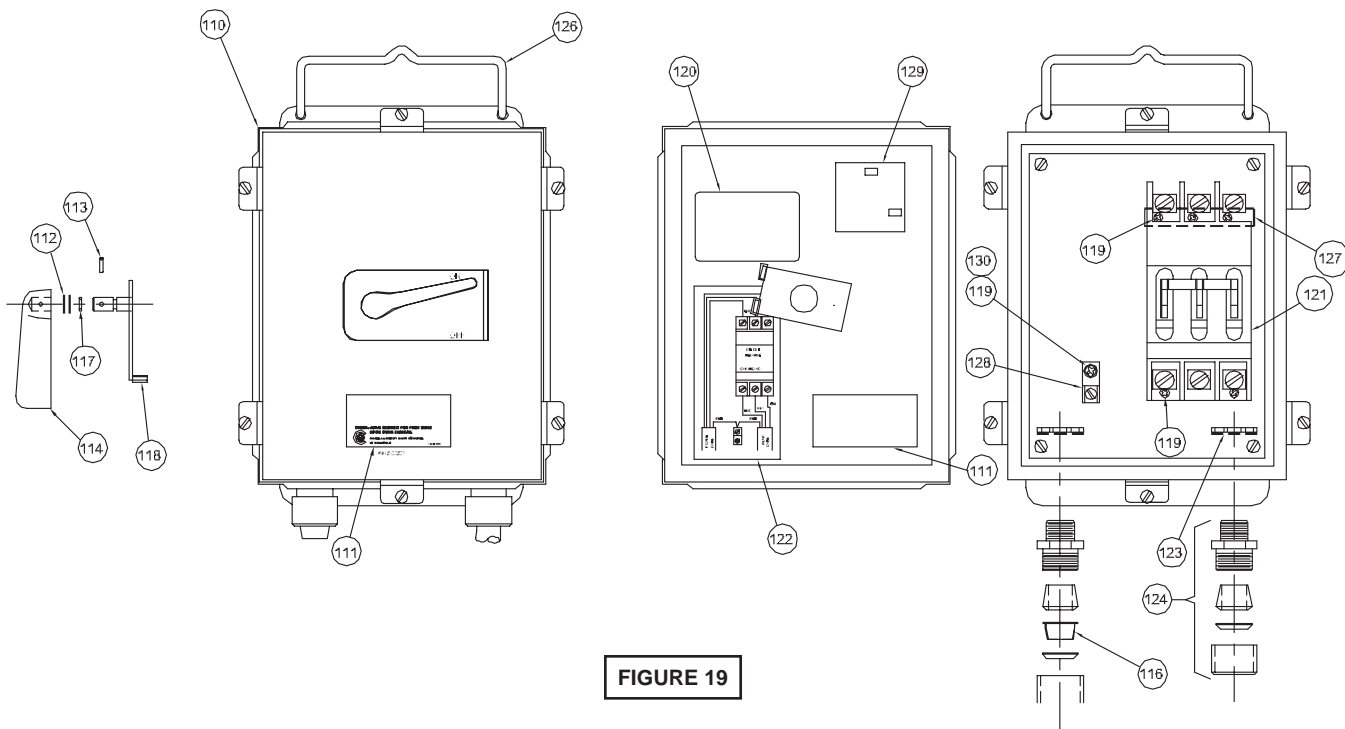

FIGURE 19

### PARTS LIST

| ITEM | QTY | PART NO.    | DESCRIPTION                         |
|------|-----|-------------|-------------------------------------|
| 91.  | 1   | SEE TABLE 4 | Capacitor, Run (Fig. 14)            |
| 98.  | 1   | SEE TABLE 4 | Capacitor, Start (Fig. 14)          |
| 99.  | 1   | 2-12019-1   | Clamp (Fig. 14)                     |
| 105. | 1   | 9-200853-1  | Relay, (Fig. 14) 115V               |
|      | 1   | 9-350853-1  | Relay, (Fig. 14), 230V              |
| 110. | 1   | 9-840859-1  | Enclosure, NEMA 4                   |
| 111. | 2   | 2-33237     | Name Plate                          |
| 112. | A/R | 2-21002-64  | Shim Washer                         |
| 113. | 1   | 2-28008-3   | Roll Pin                            |
| 114. | 1   | 9-840870    | Handle                              |
| 116. | 1   | 2-32066-23  | Caplug                              |
|      | 1   | 2-32066-30  | Caplug 2.75HP ONLY                  |
| 117. | 1   | 2-31003-010 | O-Ring                              |
| 118. | 1   | 9-840860    | Actuator Assembly                   |
| 119. | 6   | 2-22009-16  | Screw 8-32 x 1/2"Lg                 |
| 120. | 1   | 2-33016     | Caution Label                       |
| 121. | 1   | SEE TABLE 4 | Circuit Breaker                     |
| 122. | 1   | 2-33064     | Wiring Diagram 1 Phase              |
|      | 1   | 2-33119     | Wiring Diagram 1 Phase, 2.75HP ONLY |
|      | 1   | 2-33065     | Wiring Diagram 3 Phase              |
| 123. | 2   | 2-12055-2   | Connector, Nut                      |
| 124. | 2   | 2-12017-4   | Connector, Cable, NEMA 4            |
| 125. | 2   | 2-33011     | Label, (Not Shown)                  |
| 126. | 1   | 9-840867    | Handle, NEMA 4                      |
| 127. | 1   | 2-28014     | Mounting Bracket                    |
| 128. | 1   | 086135      | Ground Lug                          |
|      | 1   | 086335      | Ground Lug 5HP ONLY                 |
| 129. | 1   | 085809      | Name Plate, CSA                     |
| 130. | 1   | 2-21001-15  | Lockwasher #8                       |

| TABLE 4              |                            |                                |                                |
|----------------------|----------------------------|--------------------------------|--------------------------------|
| PUMP HP, VOLTS/PHASE | CAPACITOR, RUN<br>ITEM #91 | CAPACITOR, START<br>ITEM #98   | CIRCUIT BREAKER<br>ITEM #121   |
| 2.00 HP, 115/1       | N/A                        | 2-13010-14<br>125V, 705-845MFD | 9-200850-111<br>2P, 240V, 26A  |
| 2.00 HP, 230/1       | N/A                        | 2-13010-15<br>250V, 189-227MFD | 9-200850-112<br>2P, 240V, 13A  |
| 2.50 HP, 230/3       | N/A                        | N/A                            | 9-500850-134<br>2P, 480V, 9A   |
| 2.50 HP, 460/3       | N/A                        | N/A                            | 9-250850-134<br>2P, 480V, 4.5A |
| 2.50 HP, 575/3       | N/A                        | N/A                            | 9-250850-036<br>2P, 600V, 3.6A |
| 2.75 HP, 230/1       | 070965<br>370V, 25MFD      | 2-13010-15<br>250V, 189-227MFD | 9-200850-112<br>2P, 240V, 13A  |
| 3.50 HP, 230/1       | N/A                        | 2-13010-2<br>110V, 430-516MFD  | 9-350850-112<br>2P, 240V, 22A  |
| 5.00 HP, 230/1       | N/A                        | 2-13010-2<br>110V, 430-516MFD  | 9-350850-112<br>2P, 240V, 22A  |
| 5.00 HP, 230/3       | N/A                        | N/A                            | 9-815850-136<br>2P, 600V, 18A  |
| 5.00 HP, 460/3       | N/A                        | N/A                            | 9-500850-134<br>2P, 480V, 9A   |
| 5.00 HP, 575/3       | N/A                        | N/A                            | 9-500850-036<br>2P, 600V, 7.2A |

N/A = Not Applicable

## Single Phase & Three Phase Control Panel Schematics

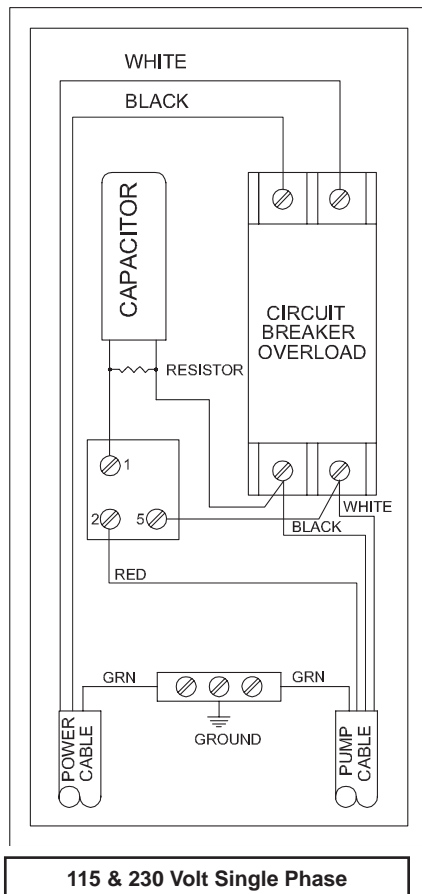
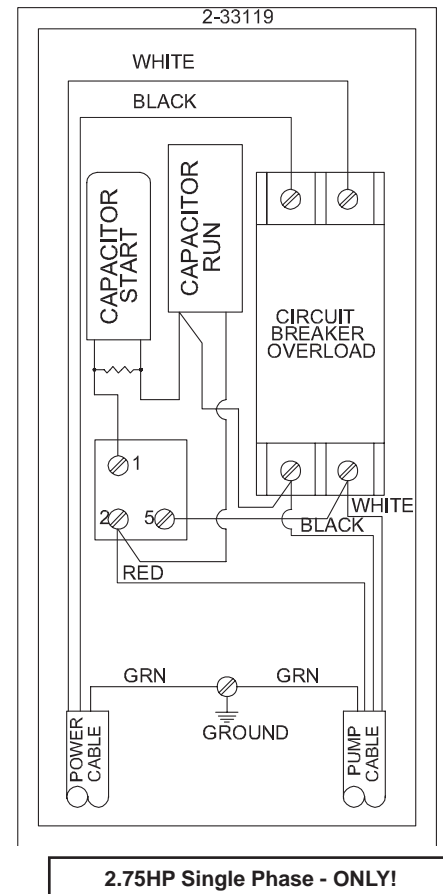

FIGURE 20



## 230, 460, 575 Volt, Three Phase Control Panel Schematics

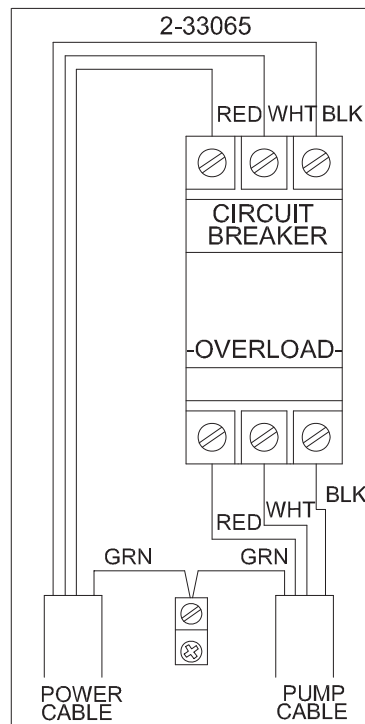
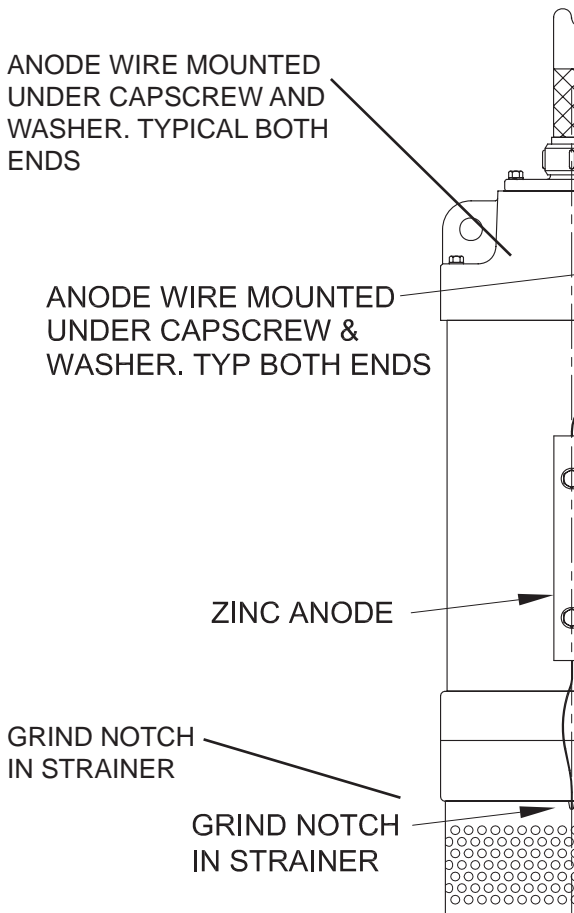

FIGURE 20 - Cont.

### Galvanic Protection Kit P/N: 9-500572



#### PARTS LIST

| QTY | PART NO.    | DESCRIPTION                      |
|-----|-------------|----------------------------------|
| 2   | 2-210002-59 | Flat Washer, 1/4" Stainless      |
| 2   | 2-23021-58  | HxHd Screw, 1/4-20 x 1.25" lg SS |
| 1   | 9-500520    | Zinc Anode Sensor                |

1. Pump must be ordered with the Galvanic Protection Kit to have the correct frame and outer shell.
2. Align two clearance holes in outer shell with the two drilled and tapped holes in frame, before tightening cap screws on the suction nozzle.
3. Fill the two drilled & tapped holes in frame approximately half full of electrical bonding grease part number 2-45003-1.
4. Install washers and capscrews through zinc anode and into the frame holes, partially filled with bonding grease and tighten securely.
5. Route wire from anode to the suction nozzle. Loosen suction nozzle capscrew & washer and install wire between washer & suction nozzle, retighten capscrew. Route other wire to discharge head and install under discharge head capscrew and washer.
6. Slip suction strainer on pump, align mounting screws, mark strainer where anode wire passes between suction nozzle and strainer. Grind a notch in the strainer to allow clearance for the wire. Install the strainer.

## Series Adapter Kit

**Pump Models: 9-20000, 9-25000, 9-55000 .... P/N: 9-250770**

**Pump Models: 9-27000, 9-35000, 9-50000 .... P/N: 9-500770**

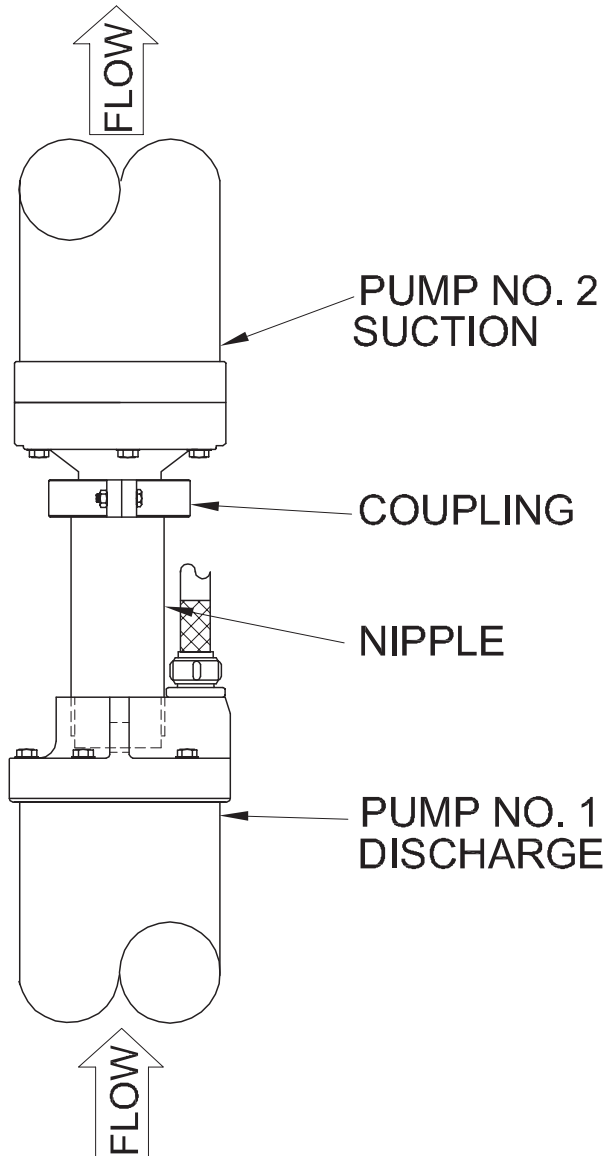

### PARTS LIST

#### P/N: 9-250770

| QTY | PART NO.  | DESCRIPTION                     |
|-----|-----------|---------------------------------|
| 1   | 2-32026-1 | Nipple, Reducer, 2" NPT x 8" Lg |
| 1   | 2-32016   | Coupling, 3" Victaulic          |

#### P/N: 9-500770

| QTY | PART NO.  | DESCRIPTION                       |
|-----|-----------|-----------------------------------|
| 1   | 2-32015-1 | Nipple, Victaulic, 3" NPT x 6" Lg |
| 1   | 2-32016   | Coupling, 3" Victaulic            |

BARNES®

BARNES®  
PRESSURE SYSTEMS  
**PS**

**CROWN**

**burks®**

**WEINMAN®**

**DEMING®**

**PROSSER®**

## *Limited 24 Month Warranty*

Crane Pumps & Systems warrants that products of our manufacture will be free of defects in material and workmanship under normal use and service for twenty-four (24) months after manufacture date, when installed and maintained in accordance with our instructions. This warranty gives you specific legal rights, and there may also be other rights which vary from state to state. In the event the product is covered by the Federal Consumer Product Warranties Law (1) the duration of any implied warranties associated with the product by virtue of said law is limited to the same duration as stated herein, (2) this warranty is a LIMITED WARRANTY, and (3) no claims of any nature whatsoever shall be made against us, until the ultimate consumer, his successor, or assigns, notifies us in writing of the defect, and delivers the product and/or defective part(s) freight prepaid to our factory or nearest authorized service station. Some states do not allow limitations on how long an implied warranty lasts, so the above limitation may not apply. **THE SOLE AND EXCLUSIVE REMEDY FOR BREACH OF ANY AND ALL WARRANTIES WITH RESPECT TO ANY PRODUCT SHALL BE TO REPLACE OR REPAIR AT OUR ELECTION, F.O.B. POINT OF MANUFACTURE OR AUTHORIZED REPAIR STATION, SUCH PRODUCTS AND/OR PARTS AS PROVEN DEFECTIVE. THERE SHALL BE NO FURTHER LIABILITY, WHETHER BASED ON WARRANTY, NEGLIGENCE OR OTHERWISE.** Unless expressly stated otherwise, guarantees in the nature of performance specifications furnished in addition to the foregoing material and workmanship warranties on a product manufactured by us, if any, are subject to laboratory tests corrected for field performance. Any additional guarantees, in the nature of performance specifications must be in writing and such writing must be signed by our authorized representative. Due to inaccuracies in field testing if a conflict arises between the results of field testing conducted by or for user, and laboratory tests corrected for field performance, the latter shall control. **RECOMMENDATIONS FOR SPECIAL APPLICATIONS OR THOSE RESULTING FROM SYSTEMS ANALYSES AND EVALUATIONS WE CONDUCT WILL BE BASED ON OUR BEST AVAILABLE EXPERIENCE AND PUBLISHED INDUSTRY INFORMATION. SUCH RECOMMENDATIONS DO NOT CONSTITUTE A WARRANTY OF SATISFACTORY PERFORMANCE AND NO SUCH WARRANTY IS GIVEN.**

This warranty shall not apply when damage is caused by (a) improper installation, (b) improper voltage (c) lightning (d) excessive sand or other abrasive material (e) scale or corrosion build-up due to excessive chemical content. Any modification of the original equipment will also void the warranty. We will not be responsible for loss, damage or labor cost due to interruption of service caused by defective parts. Neither will we accept charges incurred by others without our prior written approval.

This warranty is void if our inspection reveals the product was used in a manner inconsistent with normal industry practice and/or our specific recommendations. The purchaser is responsible for communication of all necessary information regarding the application and use of the product. **UNDER NO CIRCUMSTANCES WILL WE BE RESPONSIBLE FOR ANY OTHER DIRECT OR CONSEQUENTIAL DAMAGES, INCLUDING BUT NOT LIMITED TO TRAVEL EXPENSES, RENTED EQUIPMENT, OUTSIDE CONTRACTOR FEES, UNAUTHORIZED REPAIR SHOP EXPENSES, LOST PROFITS, LOST INCOME, LABOR CHARGES, DELAYS IN PRODUCTION, IDLE PRODUCTION, WHICH DAMAGES ARE CAUSED BY ANY DEFECTS IN MATERIAL AND/OR WORKMANSHIP AND/OR DAMAGE OR DELAYS IN SHIPMENT. THIS WARRANTY IS EXPRESSLY IN LIEU OF ANY OTHER EXPRESS OR IMPLIED WARRANTY, INCLUDING ANY WARRANTY OF MERCHANTABILITY OR FITNESS FOR A PARTICULAR PURPOSE.**

No rights extended under this warranty shall be assigned to any other person, whether by operation of law or otherwise, without our prior written approval.

**CRANE**<sup>®</sup>

**PUMPS & SYSTEMS**

A Crane Co. Company

420 Third Street  
Piqua, Ohio 45356  
Phone: (937) 778-8947  
Fax: (937) 773-7157  
www.cranepumps.com

83 West Drive, Brampton  
Ontario, Canada L6T 2J6  
Phone: (905) 457-6223  
Fax: (905) 457-2650



**IMPORTANT!  
WARRANTY REGISTRATION**

Your product is covered by the enclosed Warranty.  
To complete the Warranty Registration Form go to:

<http://www.cranepumps.com/ProductRegistration/>

If you have a claim under the provision of the warranty, contact your local  
Crane Pumps & Systems, Inc. Distributor.

**RETURNED GOODS**

**RETURN OF MERCHANDISE REQUIRES A "RETURNED GOODS AUTHORIZATION".  
CONTACT YOUR LOCAL CRANE PUMPS & SYSTEMS, INC. DISTRIBUTOR.**



**Products Returned Must Be Cleaned, Sanitized,  
Or Decontaminated As Necessary Prior To Shipment,  
To Insure That Employees Will Not Be Exposed To Health  
Hazards In Handling Said Material. All Applicable Laws  
And Regulations Shall Apply.**

