



**PRICE PUMP CO.**



**SP150 PARTS LIST**

Effective: February 11, 1998

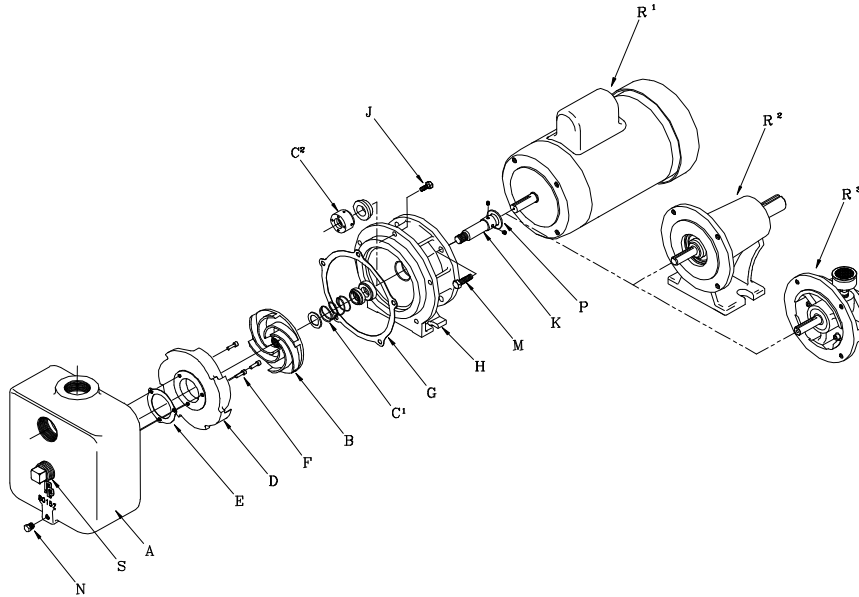

	<u>SP150AI</u>	<u>SP150AI &amp; SP150SS</u>	<u>SP150SS</u>
A. Volute	0962		0967
B. Impeller:			
4.75 - .50 Vn Ht	3264-475A		3272-475A
4.75 - .44 Vn Ht	3264-475B		3272-475B
4.75 - .31 Vn Ht	3264-475C		3272-475C
4.75 - .25 Vn Ht	3264-475D		3272-475D
4.75 - .12 Vn Ht	3264-475E		3272-475E
4.625 - .12 Vn Ht	3264-463E		3272-463E
4.25 - .12 Vn Ht	3264-425E		3272-425E
4.25 - .07 Vn Ht	3264-425F		3272-425F
Seal with Seat:			
C <sup>1</sup> . T.21 Buna on Cast Iron pump		1112	
T.21 Fluorocarbon on SS pump		0549	
C <sup>2</sup> . T.9 PTFE (opt)		0551	
Seat pin for T.9 (not shown)		0890	
D. Diffuser	0963		0968
E. Diffuser Gasket	0966 (Syn Fiber)		0971 (PTFE)
F. Diffuser Bolts (3 rqd)		0977	
G. Volute Gasket	0965 (Syn Fiber)		0970 (PTFE)
H. Bracket	0964		0969
J. Volute Bolts (5 rqd)	0911		0976
K. Shaft w/Setscrews		0270-1	
M. Motor Bolts (4 rqd)		0588	
N. 1/8" Pipe Plug	0557		0559
S. 1" Pipe Plug (CI only)	0562		N/A
P. Slinger, 7/8"		0522	
R <sup>1</sup> . Motor - Specify P/N			
R <sup>2</sup> . Power Frame		5478	
R <sup>3</sup> . Air Motor - Specify P/N			

**SP150 Repair Parts Kit**

Repair Kits includes: Gasket, Shaft w/SS, and Slinger  
 All Iron - P/N 0987  
 Stainless Steel - P/N 0989

**Note: Seal/seat must be ordered in addition to repair kit.**  
 3/4" T.21 Buna for Cast Iron (std), T.21 Fluorocarbon for SS (std)

AI = All Iron  
 AB = All Bronze  
 BF = Bronze Fitted  
 SS = Stainless Steel  
 Vn Ht = Vane Height

**Price® Pump Company**

21775 8th Street East ♦ P.O. Box Q ♦ Sonoma, CA 95476-0329 ♦ (707) 938-8441 ♦ Fax (707) 938-0764