

BRONZE PEDESTAL RUBBER IMPELLER PUMP

PIPE SIZE: 3/4"

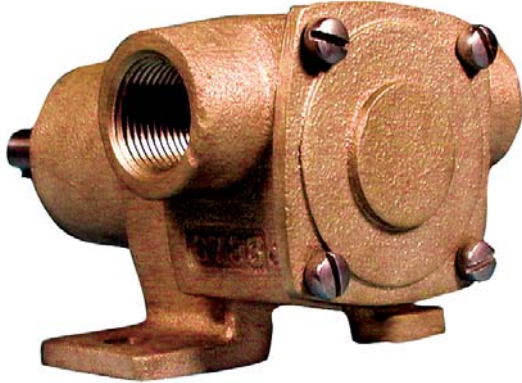

FEATURES

- Bronze Construction - Corrosion Resistance
- Large Suction and Discharge Ports
- Teflon(R)* Barrier Seals Protecting Ball Bearings
- Mechanical Carbon Ring, Ceramic Face Main Pump Seal Standard, Optional Buna N Lip Seal
- Two Sealed Ball Bearings Spaced for Maximum Load Ability
- Large Vent & Drain Openings Separate Seal & Bearing Areas
- Shaft Slinger for Additional Bearing Protection
- Neoprene Impeller Standard, Buna N Impeller Optional
- High Chrome Nickel Stainless Steel Shaft
- Extra Capacity Ball Bearings plus Rugged Construction for Prolonged Service Life
- Impeller Easily Replaced
- Buna N O-ring Between Body and Cover Eliminates Gasket Problems
- Machined-in cam for reduced impeller wear.

ROTATION

Direction of shaft rotation determines inlet and outlet ports (see line drawing)

MOUNTING

Pump will operate satisfactorily when mounted in any position. **DO NOT RUN DRY.** Rubber impeller pumps generate high rubbing friction unless lubricated by liquid pumped. Lack of liquid will cause impeller to burn up.

DRIVE

Either direct drive with flexible coupling or pulley drive can be used. Make sure both flexible coupling halves are properly aligned. When using pulley, do not overtighten belt.

PERFORMANCE

Capacity Water at 60°F

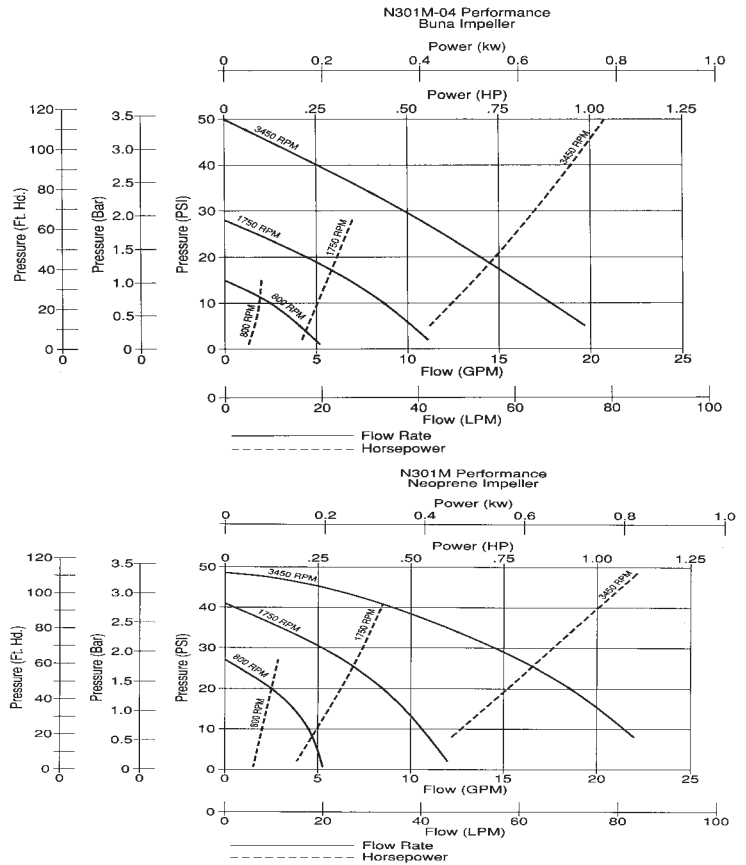

LIQUIDS AND TEMPERATURE

Liquids compatible with neoprene can be pumped including fresh and salt water solutions and mild chemicals. Do not pump severe solvents or acids. When possible, flush pump with fresh water after each usage. Buna N impellers can handle oil contaminated water and kerosene at reduced impeller service life.

Extremes of cold and heat will affect impeller life. Limits of 40° to 140° F should be observed. Do not allow liquid in pump to freeze. Drain pump by loosening cover screws. Use methyl alcohol based anti-freeze compounds such as Zerex, Shell Zone, Pyro Permanent, Permagard, Dowgard.

SUCTION LIFT

Suction lift of 15 feet is possible when impeller is wet. Suction lines must be air tight in order for pump to self prime. A foot valve at beginning of suction line is recommended.

IMPELLER REPLACEMENT

The impeller must be replaced if it is worn out or has been damaged by debris or by running the pump dry. Symptoms of a defective

*Teflon(R) is a registered trademark of DuPont. Teflon(R) or equivalent PTFE will be used.

BRONZE PEDESTAL RUBBER IMPELLER PUMP

EXPLODED VIEW AND PARTS LIST

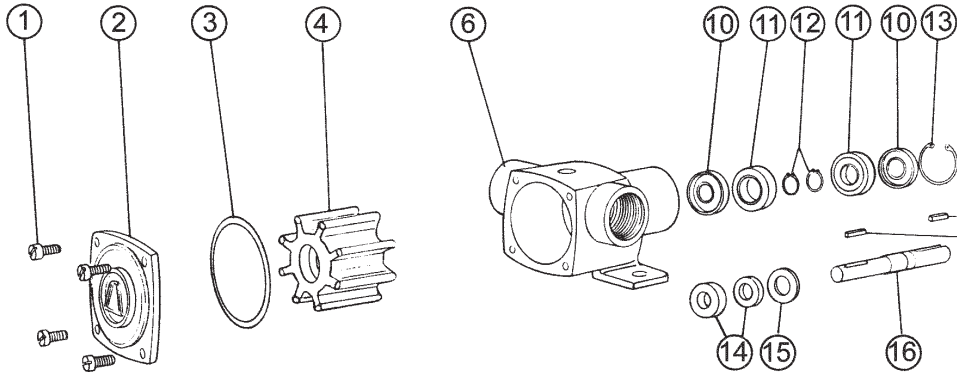

Pump	Impeller	Seal
N301M	Neoprene	Buna N Mechanical
N301M-01	Neoprene	Buna N Lip Seal
N301M-04	Buna N	Buna N Mechanical

Pump No.	1	2	3 ¹	4 ¹	6	10	11	12	13	14 ¹	15	16	17	18	Repair Kit ¹
	Screw	Cover	O-Ring	Impeller	Body	Lip Seal	Ball Bearing	Snap Ring	Snap Ring	Mech/Lip Seal	Washer	Shaft	Key Intern.	Key Exter.	
	4 Reqd	1 Reqd	1 Reqd	1 Reqd	1 Reqd	2 Reqd	1 Reqd	2 Reqd	2 Reqd	1 Reqd	1 Reqd	1 Reqd	1 Reqd	1 Reqd	
N301M	5504	6736	8231	6620	6738-1	6609	5928	5926	5925	32230	6631	6747	6739	6567	10704
N301M-01	5504	6736	8231	6620	6738-1	6609	5928	5926	5925	5463	6631	6747	6739	6567	12188
N301M-04	5504	6736	8231	8647	6738-1	6609	5928	5926	5925	32230	6631	6747	6739	6567	12187

¹ Repair Kits contain items 3, 4, & 14.

DIMENSIONS

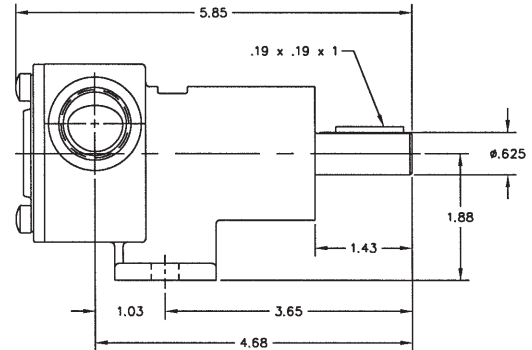
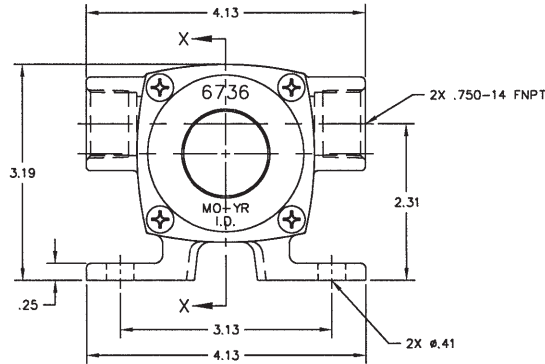
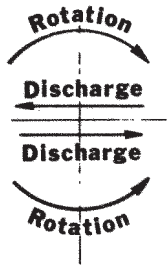

(Continued from front)

impeller are low pumping pressure and low flow causing overheating of the boat engine. Poor pump performance can also be caused by slippage of V-belts, so belts should be checked for tightness.

To replace the impeller remove screws and cover. Pull out the impeller with nose pliers or two screwdrivers. Be careful not to dent the pumping chamber with these tools. When inserting new impeller, line up key slot in impeller with the key in the shaft. Use oil on shaft and avoid forcing the impeller onto the shaft.

The impeller should also be removed for storage periods to prevent the blades from taking a permanent set.

SEAL REPLACEMENT

If water drips from the weep hole or from the area where the shaft exits the pump, the seal is defective and must be replaced. While

the Teflon(R)* barrier seal provides a first line of defense, prolonged running of the pump with a leaky seal can destroy the ball bearings resulting in catastrophic pump failure and engine shut-down.

For seal replacement, the pump must be removed from the engine and disassembled in order to gain access to the seal area. Where mechanical seals are used, both components (stationary and rotating member) must be replaced at the same time. Lip seals must be pushed out of their press-fitted position and new seals pressed into place, using a sealant on the outside of the lip seal housing.

Refer to exploded view drawings for seal location and part numbers for ordering purposes. See instructions document for details.