

CLOSE COUPLED BRONZE CENTRIFUGAL PUMP

PIPE SIZE: INLET 1 1/4", OUTLET 1"

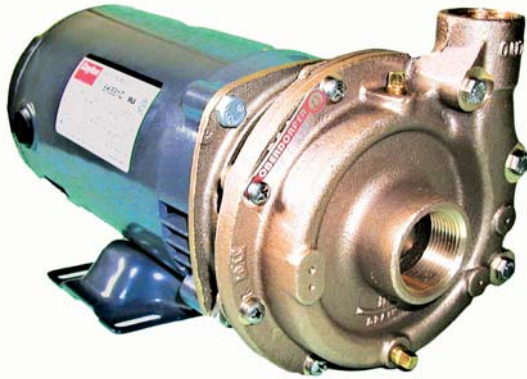

	Pump No.	Electric Motor
A	700A-F13	1/3 HP, 3450 RPM, 115 v, Single Phase, ODP
A	700AP-F57	1/3 HP, 3450 RPM, 220/440 v, Three Phase, ODP
B	700B-J19	1/2 HP, 3450 RPM, 115/230v, Single Phase, ODP
B	700BP-J57	1/2 HP, 3450 RPM, 220/440v, Three Phase, ODP
C	700C-M19	3/4 HP, 3450 RPM, 115/230v, Single Phase, ODP
C	700CP-M66	3/4 HP, 3450 RPM, 208/220v, Three Phase, ODP
D	700D-T19	1 1/2 HP, 3450 RPM, 115/230v, Single Phase, ODP
D	700DP-T57	1 1/2 HP, 3450 RPM, 220/440v, Three Phase, ODP

FEATURES

- Rugged bronze Construction
- Quiet Operation
- O-Ring housing seal eliminates gasket problems
- Wide Hydraulic Range - Four Impeller sizes
- Handles contaminated liquids
- Discharge port orientation flexibility - 8 positions
- Mechanical Seal - Carbon/Ceramic
 - Buna - standard
 - Viton® (S10) optional
 - Teflon® (S11) optional
- Pump heads mount to standard footed NEMA 56J Jet Pump Motors
- Shafts: 416 Stainless
- Multiple motor options available
- For marine version of Model 700B - see Model 109MB
- For pedestal style version of Model 700D, see Model 70P

LIQUIDS

The special pump alloys used provide corrosion resistance to many liquids including water, water solutions, and a wide range of commercial chemicals. Questions as to the chemical compatibility of special liquids should be referred to the factory.

Viscous liquids with a maximum viscosity of 2000 Saybolt Seconds Universal can be pumped. However, when pumping viscous liquids as compared with water, a reduction in flow and pressure occurs and the required horsepower rate increases.

CAPACITY Water at 70° F / 3450 RPM

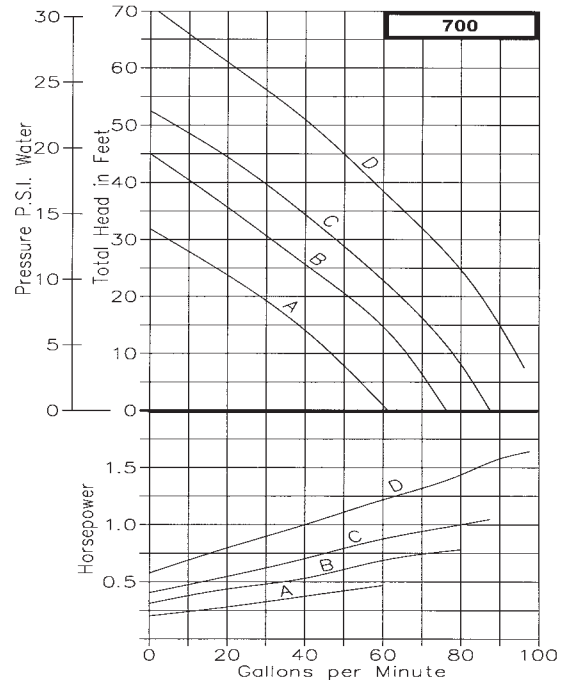

Liquids heavier than water require additional horsepower in direct proportion to the increase in specific gravity. Liquids contaminated with small solids or abrasives can be handled, but a reduction in mechanical seal life must be expected.

CHARACTERISTICS

This close-coupled pump uses a standard NEMA C-Flange Jet Pump Motor with weld-on base and threaded shaft end to accept the pump impeller. Single phase motors are non-reversible and are wired for the proper pump rotation which is counter-clockwise looking at the inlet end of the pump. (See the dimensional drawing on back.) Three phase motors must be checked out for proper rotation when the pump is installed. Interchanging of any 2 wires in a 3-phase system will reverse motor rotation.

The pump uses a mechanical type shaft seal with a Buna N rubber element. It is suitable for water, oils, and some mild solvents and it is limited to 212°F and 75 P.S.I. Viton® seals and Teflon® seals are available for severe solvents and difficult chemicals.

These centrifugal pumps are not self-priming. They must be installed below the liquid level so that the liquid flows to the pump by gravity (flooded suction). However, if a foot valve is used at the beginning of the suction line and all air is bled from the pump by manual priming, the pump will lift on the suction side up to 15 feet. Such a system relies entirely on a non-leaking foot valve for starting capability.

The flow of a centrifugal pump can be conveniently controlled by a throttling valve in the discharge line without the need for a relief valve. In centrifugal pumps, the horsepower demand will decrease as the pressure increases. Maximum horsepower occurs with a wide open discharge.

CLOSE COUPLED BRONZE CENTRIFUGAL PUMP

EXPLODED VIEW AND PARTS LIST

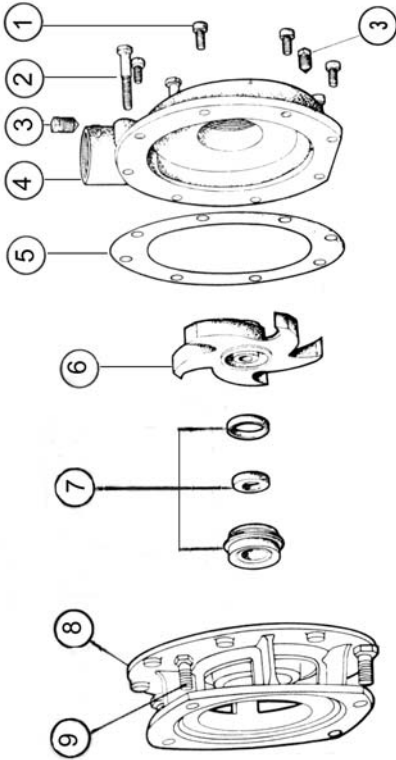

Pump No	1	2	3	4	5	6	7	8	9	11	Repair Kit
	Screw	Screw	Plug	Body	O-Ring	Impeller	Seal Assy	Adapter	Screw	Set Screw	
700A	9783-04	9783-14	6052	5266	9797-157	6075	32154	5251	5411		10697
700A S10	9783-04	9783-14	6052	5266	9797-157	6296	32210	5251	5411		11046
700A S11	9783-04	9783-14	6052	5266	9355-157S	6296	32211	6300	5411		12272
700AP	9783-04	9783-14	6052	5266	9797-157	6078	32154	5251	5411	9849	10859
700AP S10	9783-04	9783-14	6052	5266	9797-157	7195	32210	5251	5411	9849	12271
700AP S11	9783-04	9783-14	6052	5266	9355-157S	7195	32211	6300	5411	9849	12273
700B	9783-04	9783-14	6052	5266	9797-157	6076	32154	5251	5411		10698
700B S10	9783-04	9783-14	6052	5266	9797-157	6297	32210	5251	5411		12274
700B S11	9783-04	9783-14	6052	5266	9355-157S	6297	32211	6300	5411		12276
700BP	9783-04	9783-14	6052	5266	9797-157	6519	32154	5251	5411	9849	10860
700BP S10	9783-04	9783-14	6052	5266	9797-157	7196	32210	5251	5411	9849	12275
700BP S11	9783-04	9783-14	6052	5266	9355-157S	7196	32211	6300	5411	9849	12277
700C	9783-04	9783-14	6052	5266	9797-157	6077	32154	5251	5411		10699
700C S10	9783-04	9783-14	6052	5266	9797-157	6180	32210	5251	5411		12278
700C S11	9783-04	9783-14	6052	5266	9355-157S	6180	32211	6300	5411		12280
700CP	9783-04	9783-14	6052	5266	9797-157	6520	32154	5251	5411	9849	10861
700CP S10	9783-04	9783-14	6052	5266	9797-157	7197	32210	5251	5411	9849	11697
700CP S11	9783-04	9783-14	6052	5266	9355-157S	7197	32211	6300	5411	9849	12281
700D	9783-04	9783-14	6052	5266	9797-157	5267	32154	5251	5411		10700
700D S10	9783-04	9783-14	6052	5266	9797-157	6179	32210	5251	5411		12282
700D S11	9783-04	9783-14	6052	5266	9355-157S	6179	32211	6300	5411		12284
700DP	9783-04	9783-14	6052	5266	9797-157	6521	32154	5251	5411	9849	10861
700DP S10	9783-04	9783-14	6052	5266	9797-157	7198	32210	5251	5411	9849	11729
700DP S11	9783-04	9783-14	6052	5266	9355-157S	7198	32211	6300	5411	9849	12285

Notes: Repair Kits contain items 5, 6, 7 & 11 (and includes impeller shims 602502 and 602503, gasket for older units)

DIMENSIONS

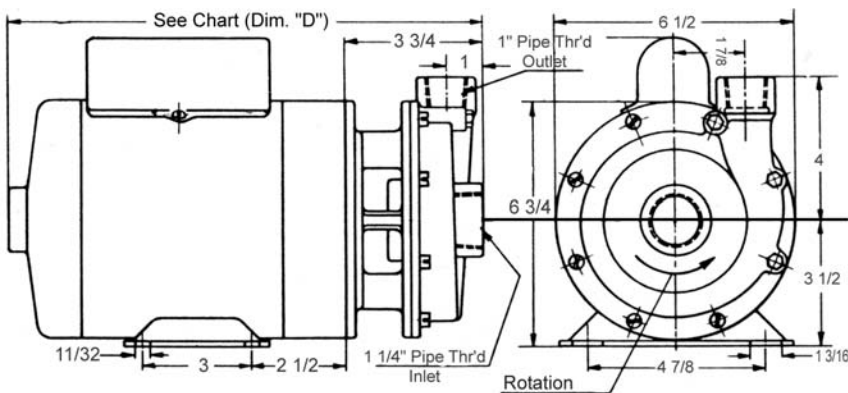

	Pump No.	Impeller Dia.	"D" Dim.
A	700A-F13	3.0	12 1/8
	700AP-F57		
B	700B-J19	3.5	12 7/8
	700BP-J57		
C	700C-M19	3.75	13
	700CP-M66		
D	700D-T19	4.25	14
	700DP-T57		

*Viton® is a registered trademark of DuPont Dow Elastomers. Viton® or equivalent FKM will be used. Teflon® is a registered trademark of DuPont. Teflon® or equivalent PTFE will be used.