

RUBBER IMPELLER PUMP BRONZE CLOSE COUPLED

405MG-03UGY



405MK-04N26



Model	Motor or Engine					
	Part #	HP	Speed	Enclosure	Voltage	
405M(K)-04M26	7048	3/4	1725	ODP	115/230	AC single phase
405M-04M35	9903	3/4	1725	TEFC	115/230	AC single phase
405M-04M97	8470	3/4	1725	TEFC	230/460	AC three phase
405M-04M09	8758	3/4	1725	XP	115/230	AC single phase
405M(K)-04N26	7055	1	1725	ODP	115/230	AC single phase
405M(K)-04N95	8476	1	1725	ODP	230/460	AC three phase
405M-04M74	8224	3/4	1800	TEFC	24	DC
405M-04M75	7996	3/4	1800	TEFC	12	DC
405M-04N76	9759	1	1800	TEFC	24	DC
405M-04N75	2472	1	1800	TEFC	12	DC
405MG-03UGY	7230	3				Gasoline Engine

FEATURES

- All Bronze Construction
- Stainless Steel Shafts
- Portable
- Compact
- Easy Impeller Replacement
- Vacuum Switch Shut-off Optional
- AC Power Cord

GENERAL DESCRIPTION

Close coupled Rubber Impeller Pumps are made of high quality bronze for maximum corrosion resistance. The rubber impeller is mounted on a separate stainless steel shaft which is counterbored on the outer end in order to slide over the carbon steel motor shaft. Ball or sleeve bearings in the motor or engine support the shaft. Model 405M has a mechanical seal. Impellers are made of Neoprene rubber, Buna N impellers are available on request. (405M-07)

PERFORMANCE

WATER 60° F

FEET HD.	DISCHARGE PRESSURE					
	0	20	40	60	80	100
P.S.I.	0	8.7	17.3	26	34.6	42.8
FLOW G.P.M	25	24	22	17	11	7
HORSEPOWER	3/4	3/4	3/4	1	1	1

Flexible blades on the periphery of the impeller provide the pumping action. While the impeller rotates, the liquid between the blades is continuously squeezed out into the discharge port by a cam located inside the pumping chamber. The flow may be throttled or shut off for a short period without the need of a relief valve.

DRIVE ARRANGEMENT

Close coupled Rubber Impeller Pumps are mounted directly onto the motor without the use of a shaft coupling. This pump is designed to be coupled to a Nema C 56C faced motor. It uses an aluminum adapter plate to accommodate the pump. The gas engine mount has its own adapter.

LIQUIDS AND TEMPERATURE

Liquids handled by Rubber Impeller Pumps with standard Neoprene impellers are primarily fresh or salt water and water solutions. Rubber Impeller Pumps are not suitable for pumping gasoline or solvents. Buna N (405M-07) impellers can handle oil contaminated water and kerosene at reduced impeller service life.

Liquid temperature range is from 40° F to 140°F. If freezing conditions are expected, the pump should be drained by loosening the cover screws and the pump chamber should be filled with methyl alcohol based antifreeze. Viscous liquids and oils can not be pumped with Rubber Impeller Pumps.

SUCTION LIFT

On initial start-up Rubber Impeller Pumps must be primed to prevent dry-running of the impeller. Suction lifts of 15 ft. are possible when pump is fully primed. A foot valve with built-in strainer at the beginning of the suction line is recommended. Suction lines should be as short as possible.

RUBBER IMPELLER PUMP BRONZE CLOSE COUPLED

EXPLODED VIEW & PARTS LIST

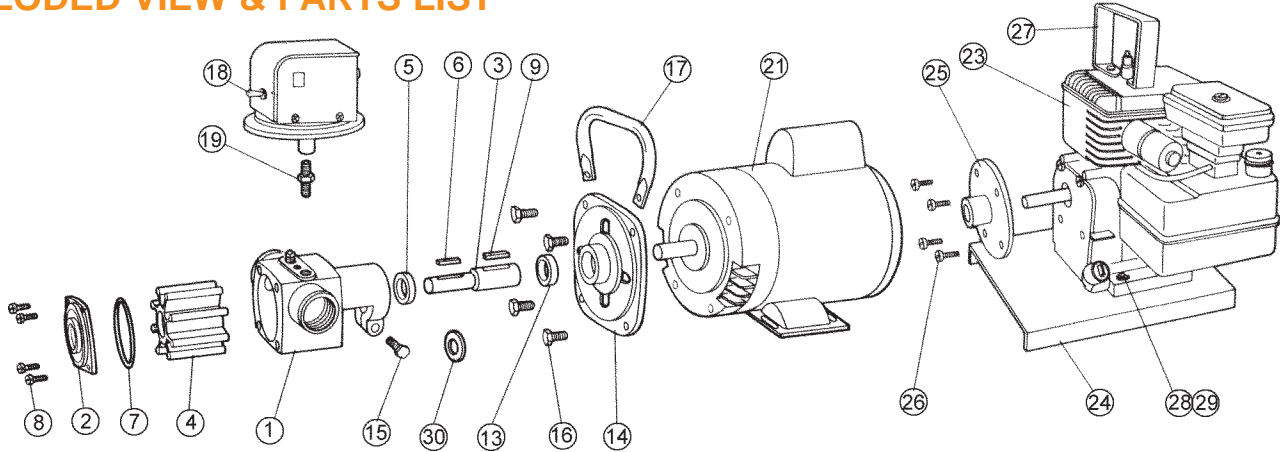

Pump No.	1	2	3	4 ⁵	5	6	7	8	9	10 ²	11 ²	12 ²	13	14	15	16
	Body	Cover	Shaft Exten.	Impeller	Seal Assy.	Key	O-Ring	Screw	Key	Terminal Spade	Wire Nut Orange	Wire Nut Yellow	Collar	Adapter	Screw	Screw
	1 Reqd	1 Reqd	1 Reqd	1 Reqd	1 Reqd	1 Reqd	1 Reqd	4 Reqd	1 Reqd	5 Reqd	1 Reqd	2 Reqd	1 Reqd	1 Reqd	1 Reqd	4 Reqd
405M-04	7040	6625	7041	6603	32230	5475	8230	5504	6845	---	---	---	5886	7459	5595	5411
405M-04M26	7040	6625	7041	6603	32230	5475	8230	5504	6845	---	---	---	5886	7459	5595	5411
405M-04N26	7040	6625	7041	6603	32230	5475	8230	5504	6845	---	---	---	5886	7459	5595	5411
405MK-04M26	7040	6625	7041	6603	32230	5475	8230	5504	6845	7297	9850	9857	5886	7459	5595	5411
405MK-04N26	7040	6625	7041	6603	32230	5475	8230	5504	6845	7297	9850	9857	5886	7459	5595	5411
405MG-03UGY	7040	6625	7041	6603	32230	5475	8230	5504	6845	---	---	---	5886	---	5595	---

Pump No.	17 ¹	18 ⁴	19	20 ²	21	22 ²	23	24	25	26	27	28	29	30	Repair Kit ³	Vacuum Switch Kit ⁴
	Handle Motor	Vacuum Switch	Nipple	Short Cord	Motor	Long Cord	Engine	Base	Adapter	Screw	Handle Engine	Screw	Nut	Washer		
	1 Reqd	1 Reqd	1 Reqd	1 Reqd	1 Reqd	1 Reqd	1 Reqd	1 Reqd	1 Reqd	4 Reqd	1 Reqd	4 Reqd	4 Reqd	1 Reqd		
405M-04	---	---	---	---	---	---	---	---	---	---	---	---	---	6631	10955	---
405M-04M26	9773	---	---	---	7048	7044	---	---	---	---	---	---	---	6631	10955	---
405M-04N26	9773	---	---	---	7055	7044	---	---	---	---	---	---	---	6631	10955	---
405MK-04M26	9773	7046	7050	7047	7048	7044	---	---	---	---	---	---	---	6631	10955	10798
405MK-04N26	9773	7046	7050	7047	7055	7044	---	---	---	---	---	---	---	6631	10955	10798
405MG-03UGY	---	7290	---	---	---	---	7230	6742	7517	7610	6765	6057	5597	6631	10955	10979

¹When (9773) handle is used, two item 16 (5411) screws are replaced with two (5974) screws and two (6831) flat washers.

² Items 10, 11, 12, 20 & 22 are not shown in illustration.

³ Repair Kit contains items 4, 5 & 7. ⁴ Vacuum Switch Kit contains items 11, 19, 20, 23 and two (7298) terminal rings.

⁴ Vacuum switch for gas engine model is 7290

⁵ Impeller in Buna (-07) is 8515, Repair Kit is 12220

⁶ For conversion to 406M-4 Macerator pump, order Macerator Kit 10827

DIMENSIONS 405M-04M26

