

BRONZE CLOSE COUPLED RUBBER IMPELLER PUMP

PIPE SIZE 3/4"



305M-C81

FEATURES

- Bronze construction - Corrosion resistant
- Reversible wearplate
- Buna Mechanical seal
- Portable
- Slotted motor base
- Neoprene Impeller STD (Buna optional 305M-02)
- Stainless Steel Shaft
- Buna O-ring seal between body and cover eliminates gasket problems
- Impeller and cam easily replaced
- Available with AC or DC motors

305M-08F50

IMPORTANT

Performance is based on full voltage supply. Use direct lines. Do not drain voltage with other electrical equipment on same circuit. Lower voltage reduces performance and overloads motor. Use adequate wires size and length to maintain supply voltage.

MOUNTING

Pump will operate satisfactorily when mounted in any position.

DO NOT RUN DRY

Rubber impellers generate high rubbing friction unless lubricated by liquid pumped. Lack of liquid will cause impeller to burn up.

DRIVE & ROTATION

The pump is driven directly from the electric motor shaft. An aluminum adapter connects the pump to the motor. Reversing supply leads to motor terminals reverses motor rotation. "In" and "Out" pump ports are also reversed. See diagram on reverse side.

PERFORMANCE TABLE

Water 70oF (neoprene impeller)			Feet Hd					
Model	Voltage	HP	Pressure (PSI)	10	20	40	60	80
				4.3	8.7	17.3	26.0	34.6
305M C81 8295	12 VDC	1/4	Flow (GPM)	7.1	6.7			
			Speed (RPM)	1050	1040			
			Current (Amps)	8.4	9.2			
305M C82 8295	24 VDC	1/4	Flow (GPM)	15.3	14.5	11.9	6.4	2.0
			Speed (RPM)	2200	2190	2160	2140	2120
			Current (Amps)	9.5	10.3	12.4	14.8	17.1
305M-08 C74 2924	12 VDC	1/4	Flow (GPM)	13.8	13.0	9.7		
			Speed (RPM)	1950	1930	1880		
			Current (Amps)	16.0	17.8	21.9		
305M-08 F93 3073	24 VDC	1/3	Flow (GPM)	13.8	12.9	9.6	4.7	
			Speed (RPM)	1920	1920	1910	1860	
			Current (Amps)	8.3	9.3	11.1	13.9	
305M-08 F50 8458	15/230 VAC TEFC	1/3	Flow (GPM)	12.9	12.1	8.9	4.2	
			Speed (RPM)	1780	1780	1780	1770	
305M-08 F97 8456	230/460 VAC TEFC	1/3	Flow (GPM)	12.9	12.1	8.9	4.2	
			Speed (RPM)	1780	1780	1780	1770	

Notes: **Maximum recommended operating point**

LIQUIDS AND TEMPERATURE

Liquids compatible with neoprene can be pumped including fresh and salt water solutions and mild chemicals. Do not pump severe solvents or acids. When possible flush pump with fresh water after each use.

Extremes of cold and heat will affect impeller life. Limits of 40° to 140°F should be observed. Do not allow liquid in pump to freeze. Drain pump by loosening cover screws. Use methyl alcohol based anti-freeze compounds such as Zerex, Shell Zone, Pyro Permguard, Dowgard.

SUCTION LIFT

Suction lift of 15 ft. is possible when impeller is wet. Suction lines must be air tight in order for pump to self prime. a foot valve at beginning of suction line is recommended.

IMPELLER REPLACEMENT

The impeller must be replaced if it is worn out or has been damaged by debris or by running the pump dry. Symptoms of a defective impeller are low pumping pressure and low flow

To replace the impeller remove screws and cover. Pull out the impeller with nose pliers or two screwdrivers. Be careful not to dent the pumping chamber with these tools. When inserting new impeller, line up key slot in impeller with the key in the shaft. Use oil on shaft and avoid forcing the impeller onto the shaft.

The impeller should also be removed for storage periods to prevent the blades from taking a permanent set.

SEAL REPLACEMENT

If water drips from the weep hole or from the area where the shaft exits the pump, the seal is defective and must be replaced. Prolonged running of the pump with a leaky seal can destroy the motor bearings resulting in catastrophic pump failure.

For seal replacement, the pump must be removed from the motor and disassembled in order to gain access to the seal area. Where mechanical seals are used, both components (stationary and rotating member) must be replaced at the same time.

Refer to exploded view drawings for seal location and part numbers for ordering purposes.

BRONZE CLOSE COUPLED RUBBER IMPELLER PUMP

EXPLODED VIEW AND PARTS LIST

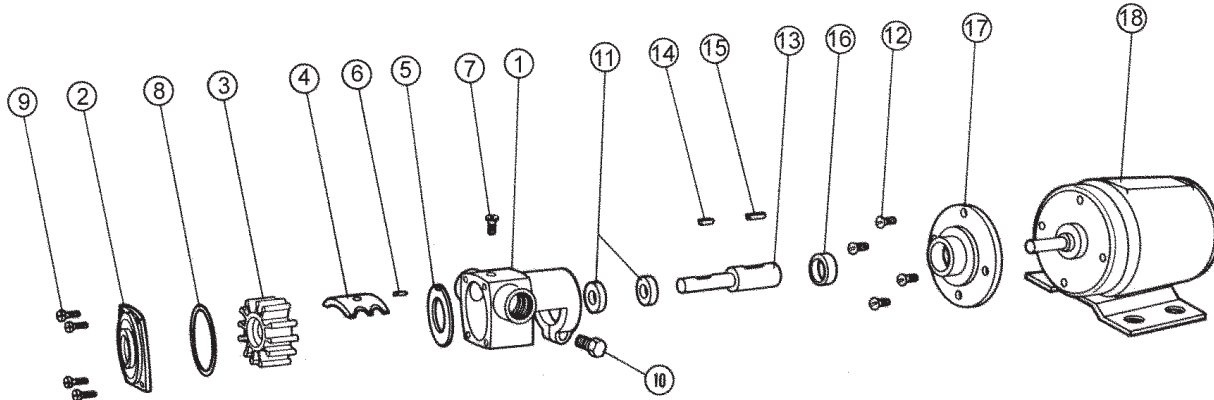

Pump No.	Config	1	2	3	4	5	6	7	8	9	10	11	12	13	14	15	16	17	18	19	Repair Kit '1
		Body 1 Req'd	Cover 1 Req'd	Impeller 1 Req'd	Cam 1 Req'd	Wear Plate 1 Req'd	Pin 1 Req'd	Screw 1 Req'd	O-ring 1 Req'd	Screw 4 Req'd	Screw 1 Req'd	Screw 1 Req'd	Seal 4 Req'd	Shaft 1 Req'd	Key 1 Req'd	Key 1 Req'd	Collar 1 Req'd	Adapter 1 Req'd	Motor 1 Req'd	Washer 1 Req'd	
305M	Neoprene	8318	6736	6620	6612	6737	6685	7300-62	8231	5504	5595	32230	5916	8319	6739	6845	7991	7990	-----	6631	10704
305M-02	Buna			8647									5916					7990	-----		12187
305M	C81	Neoprene /1/4 HP/ 12VDC		6620									5916					7990	8295		10704
305M	C82	Neoprene /1/4 HP/ 24VDC		6620									5916					7990	8295		10704
305M-08	C74	Neoprene /1/4 HP/ 12VDC		6620									5411					7459	2924		10704
305M-08	F93	Neoprene /1/4 HP/ 24VDC		6620									5411					7459	3073		10704
305M-08	F50	Neoprene /1/3 HP/ 120VAC		6620									5411					7459	8458		10704
305M-08	F97	Neoprene /1/3 HP/ 460VAC		6620									5411					7459	8456		10704

*Repair Kit includes items 3,8,11

DIMENSIONS

305M-C81

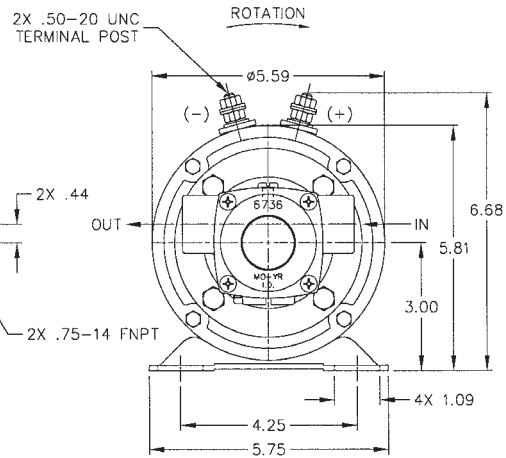
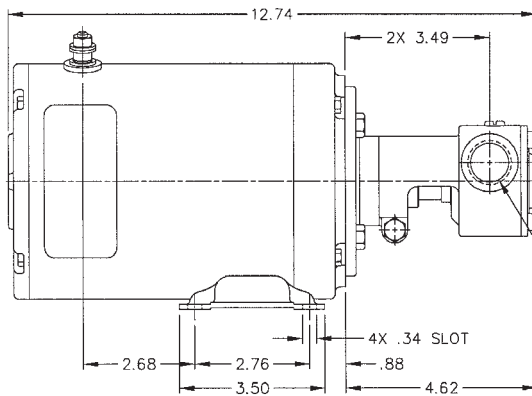

305M-08F50

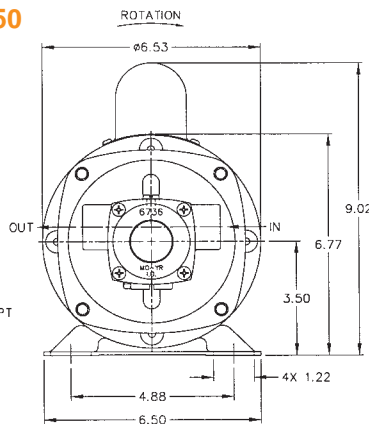
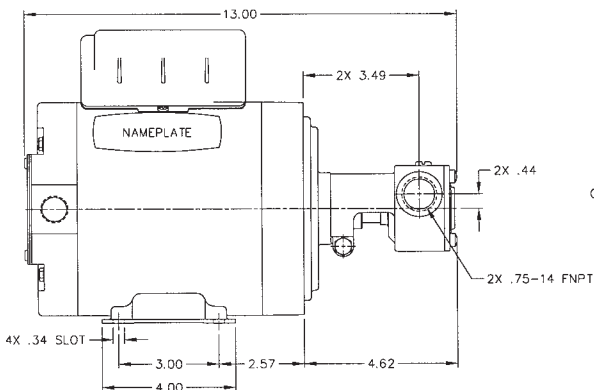

STANDARD ROTATION

