

RBS

- Rotorless
- Brushless
- Sealless

- Circulator pump for pumping glycol/water
- No maintenance (no shaft seals, bearings, brushes, or coupled magnets)
- Encapsulated electronics is totally potted to be moisture resistant
- Enclosure is splash resistant
- Motor features include solid state automatic thermal protection control, locked rotor protection with a manual circuit breaker, reverse polarity and surge protection, and automatic low/high voltage protection.

RBS is a long life, zero maintenance circulator pump for pumping glycol/water specifically for transit bus applications. The pump/motor does not have seals, bearings, or magnets to wear out or fail. The pump/motor design is a canned type with a cartridge as a single replacement item. The motor drive and motor is protected with a variety of solid-state automatic controls to achieve long life and eliminate maintenance.

SPECIFICATIONS

Housing	Aluminum 356-T6 Hardcoat Anodize
Motor Shell	Aluminum 356-T6 Hardcoat Anodize
Impeller	PPS (glass filled), enclosed, high efficiency
Cartridge	Stainless Steel shell, Silicon Carbide Bearings
Base	Zinc plated steel
O-ring seal	Viton
Fasteners	300 grade Stainless Steel
Optional	1.5 inch hose flanges or two bolt flat flange
Power Requirements	24VDC system (22-30VDC)
Glycol Temperature	230°F Maximum
Pressure	60psi Maximum
Ambient Temperature ...	200°F Maximum
Size	10 x 6.25 x 6 inches
Weight	12 lbs

MAINTENANCE FREE
CIRCULATOR PUMP

ALUMINUM 356-T6
HARDCOAT ANODIZED
HOUSING

CANNED MOTOR PUMP

NO MECHANICAL SEAL

INTERNAL THERMAL
PROTECTION

MANUAL RESET
CIRCUIT BREAKER

SEALED AND
ENCAPSULATED
ELECTRONIC CONTROLS

LONG LIFE

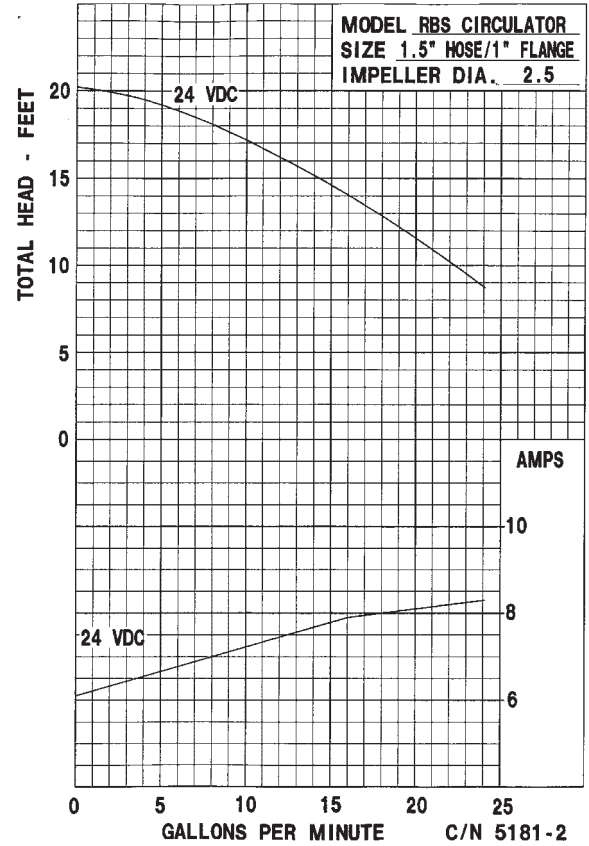
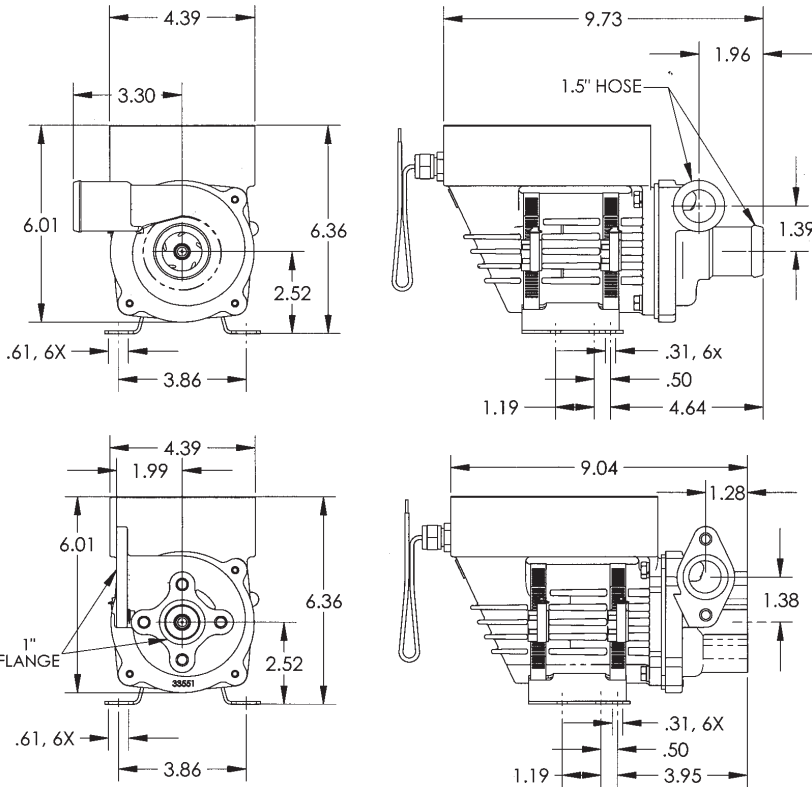

ITEM	QTY	PART NO.	DESCRIPTION
1			HOUSING OPTIONS:
	1	33552	HOUSING - FLANGED
	1	33850	HOUSING - 1.50 HOSE
2	1	33561	O-RING- VITON
3	1	33568	IMPELLER/CARTRIDGE ASY
4	1	33560	BACK PLATE
5	1	33669	MOTOR SHELL ASY
6	4	33564	LOCK WASHER SS
7	4	33563	HEX HEAD CAPSCREW SS
8	2	34246	BASE CLAMPS
9	1	28866	BASE

