

HTO 120

2" x 1 1/2" CENTRIFUGAL PUMP

AIR COOLED - NO COOLING JACKET OR FLUSH REQUIRED

HTO 120 is a patented, unique centrifugal pump designed for high temperature applications, such as the plastics, chemical, food and processing industries. The pump can be used in horizontal or vertical positions and is available with or without an electric motor.

PUMP SPECIFICATIONS

Suction and Discharge	2" x 1 1/2" NPT or 125# Flange
Housing	Ductile Iron
Drive Sleeve	Hardened 303SS
Standard Seal	Carbon/Silicon Carbide and Viton
Working Pressure	150 psi (max)
Temperature	650°F (343°C) (max)



WARNING

Consult factory for applications approval and usage. Serious injury or death caused by burns from hot oil may occur.



MP PUMPS, INC.

TECUMSEH PRODUCTS COMPANY

34800 BENNETT DRIVE • FRASER, MI 48026-1686
(586) 293-8240 • FAX (586) 293-8469

800-563-8006

www.mppumps.com

**CLOSE-COUPLED
NEMA 145TC & 184C**

2 H.P. • 3 H.P. • 5 H.P.

- With Or Without Electric Motor
- Bearing Pedestal Available

HTO 120

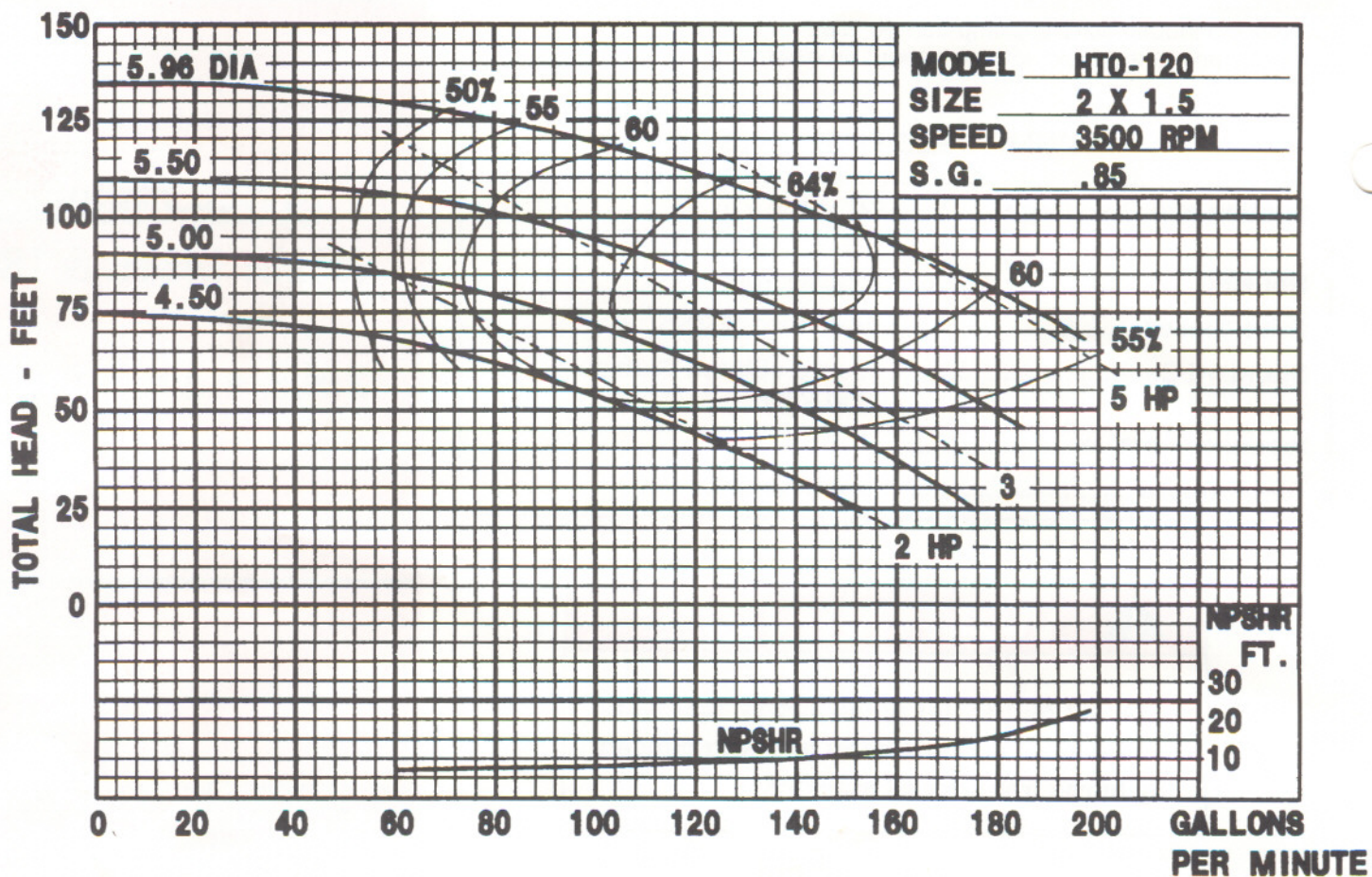
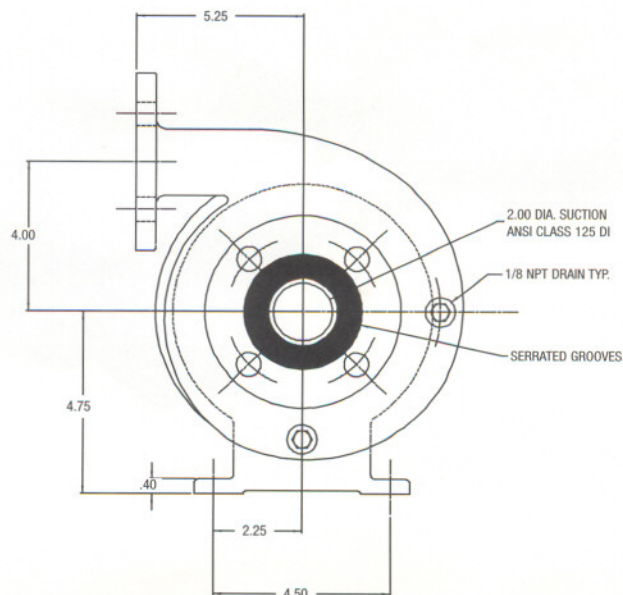
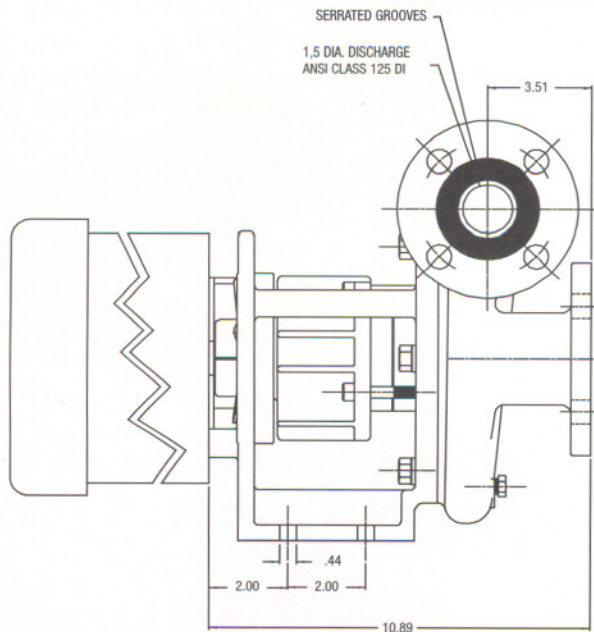

MP PUMPS, INC.

TECUMSEH PRODUCTS COMPANY
34800 BENNETT DRIVE • FRASER, MI 48026-1686
(586) 293-8240 • FAX (586) 293-8469

800-563-8006

www.mppumps.com

FORM 9051 (2/02)
Litho in USA