

EC SERIES

Economical
Cast Iron
End Suction
Centrifugal
Pumps

Complete
Pumps Available
For Immediate
Shipment

Available

- 1/2 HP
- 3/4 HP
- 1 HP
- 1.5 HP
- 2.0 HP
- 3.0 HP



Heavy Duty Cast Iron Construction
Back Pull-Out Design
NEMA Motors

Flow Rate Up To 120 GPM
Pressure Up To 140 TDH

Ideal For Light Industrial/
Commercial Water Transfer Services

Pump Specifications

Seal.....	Carbon/Ceramic/Buna
Housing.....	Cast Iron
Impeller.....	Noryl
Max. Temperature.....	160°F

MP PUMPS, INC.
TECUMSEH PRODUCTS COMPANY
34800 BENNETT DRIVE • FRASER, MI 48026-1686
(586) 293-8240 • FAX (586) 293-8469
(800) 563-8006
www.mppumps.com

EC SERIES

EC SERIES

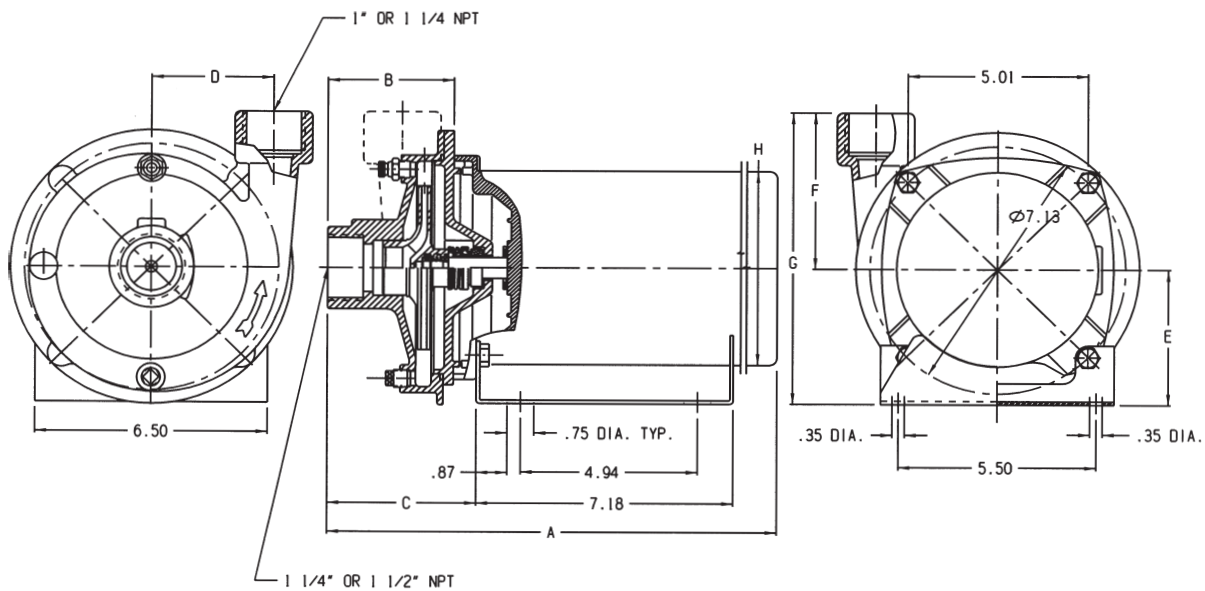
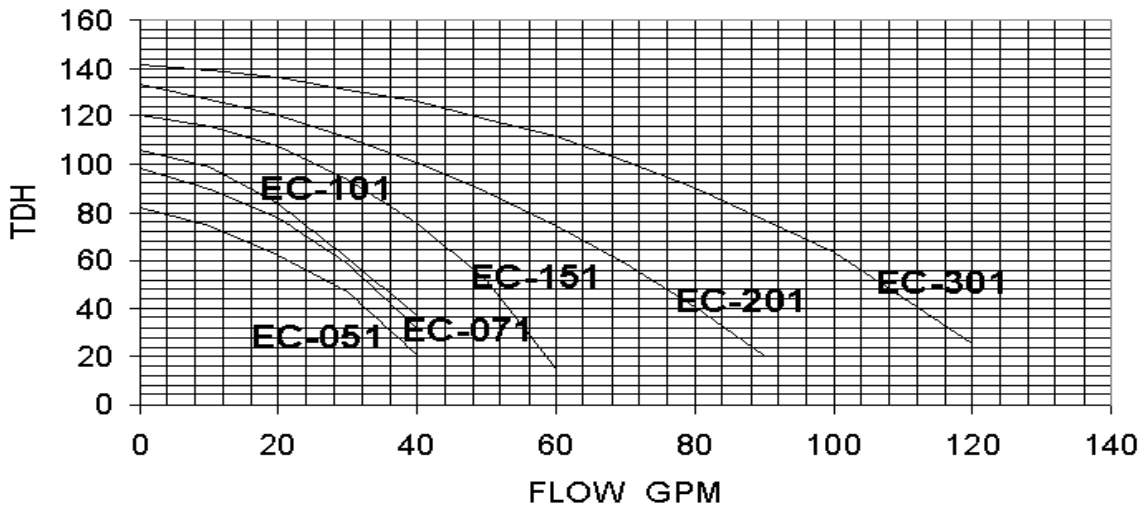

MODEL NO.	HP	VOLTAGE & PHASE	PORTS		PUMP DIMENSIONS					PACKING DIMENSIONS			WEIGHT Lbs.
			Suc	Disc	A	B	C	F	H	Inches			
EC-051	.50	115/230/1	1.25"	1.00"	14.48	2.08	4.32	4.49	5.49	15.5 X 8.5 X 10"			32
EC-071	.75	115/230/1	1.25"	1.00"	14.67	2.08	4.44	4.53	5.47	16.5 X 9.5 X 10"			34
EC-101	1	115/230/1	1.50"	1.25"	15.25	2.08	4.28	4.46	5.56	16.5 X 9.5 X 10"			35
EC-151	1.50	115/230/1	1.25"	1.00"	15.75	2.08	4.25	4.45	5.50	16.5 X 9.5 X 10"			41
EC-201	2	230/1	1.50"	1.25"	16.42	2.08	5.01	4.71	5.55	18.25 X 9.5 X 10"			43
EC-301	3	230/1	1.50"	1.25"	18.13	2.08	4.92	4.39	6.22	18.25 X 9.5 X 10"			52

All models are available in 3 Phase - specify voltage