



**ELETTROPOMPA AUTOADESCANTE
PER TRAVASO LIQUIDI
SELF-PRIMING ELECTRIC PUMP
FOR TRANSFERRING VARIOUS LIQUIDS**

**AVVERTENZE D'USO
INSTRUCTIONS FOR USE**

164 680 13 - UP12A 24 V



CE

ATTIVAZIONE VALVOLA DI SFIATO / AIR VENT VALVE ACTIVATION

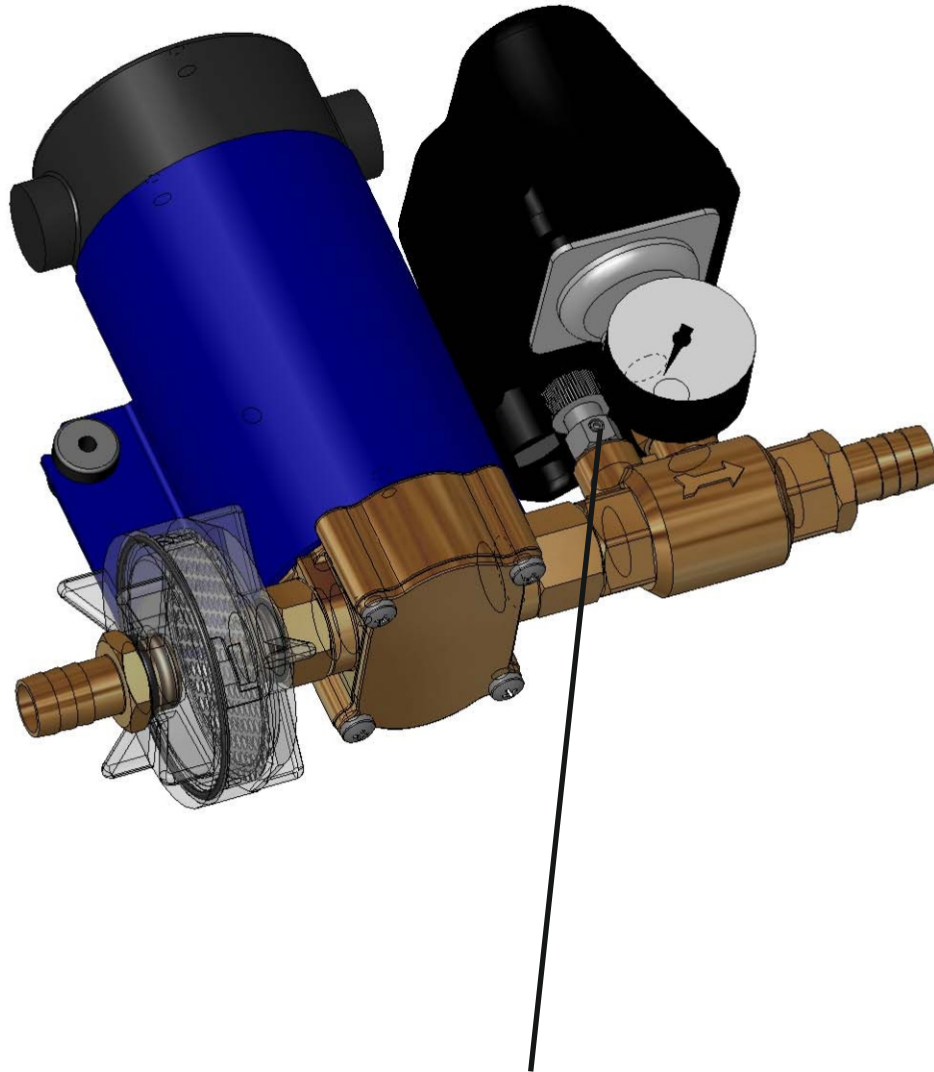

When starting the pump slightly open the small valve located next to the pressure switch, in order to let the air out and facilitate the pump priming. As soon as the pump is operating close the small valve.

All'avviamento pompa agire brevemente sulla valvolina manuale posizionata vicino al pressostato per sfogare l'aria e favorire l'adescamento pompa. Una volta azionata la pompa, richiudere la valvolina.

PRODUCT DESCRIPTION

A

Self-priming electric gear pump equipped with filter, pressure switch and non-return valve to be used as automatic pump for water pressure systems on boats, mobile homes, etc. Brass body, PTFE gears, stainless steel shaft and rubber lip seal. The pressure switch is set in the factory between 1,5 and 2,5 bar. It is advisable to fit the pump with a suitable accumulator tank (see Marco catalogue for accessories).

TECHNICAL DETAILS

B

CODICE	TIPO	VOLT	FUSIBILE	PORTATA	PRESSIONE	PESO	d.int TUBO
CODE	TYPE	VOLT	FUSE	FLOW RATE	PRESSURE	WEIGHT	PIPE ID
164 680 13	UP12/A	24	20 A	36 l/min	2,5 bar	4,9 kg	16 mm

AMBIENT CONDITIONS

C

Temperature: min. -10 °C / max. +60 °C **Relative humidity:** max. 90 %

Warning: the above indicated temperature ranges are applicable to all components of the pump and these limits must be respected in order to avoid any possible damage or malfunctioning.

ELECTRICAL CONNECTIONS

D

The electric pump must be connected to a source of direct current (either battery or transformer) with an amp rating of over 20A at nominal voltage of 24V. The pump must be protected by a suitable rated fuse.

OPERATING CYCLE

E

The pump has been designed for discontinuous use. Under conditions of high operating pressures (eg. with closed or blocked outlet, excessive length of the delivery circuit and/or excessive pressure due to accessories), the pump can be subjected to elevated stresses and overheating and therefore should not be used for prolonged periods under such conditions.

APPLICATIONS

F

There are numerous fields of applications for the pump, however only exclusively with the allowed liquids mentioned:

- main use as automatic pump for water pressure systems on boats, mobile homes, etc.

G FLUIDS ALLOWED / NOT ALLOWED

ALLOWED:

FRESH WATER AND SEA WATER

NOT ALLOWED:

PETROL (GASOLINE)
FLAMMABLE LIQUIDS with PM < 55°C
LIQUIDS WITH VISCOSITY > 20 cSt
FOODSTUFF LIQUIDS
CORROSIVE CHEMICAL PRODUCTS

SOLVENTS

RELATED DANGERS

FIRE EXPLOSION
FIRE EXPLOSION
MOTOR OVERHEATING
FOODSTUFF LIQUID CONTAMINATION
PUMP CORROSION -
INJURY TO PERSONNEL
FIRE EXPLOSION
DAMAGE TO SEALS

H TRANSPORTATION AND HANDLING

Due to limited weight and dimensions the pump does not require the use of any special handling or lifting equipment. When handling manually, normal personal protective gear should be worn (safety shoes with toe piece, etc.)

The pump is carefully packed prior to shipment. Upon receiving, the pump packaging should be inspected for damages and the pump stored in a dry area.

I INSTALLATION

It is recommended that the use of the pump be according to normative safety standards and also as per the precautions listed below.

I-1 PACKAGING ENVIRONMENTAL DISPOSAL

The packing material does not require special disposal precautions, as it is not polluting or dangerous. The user is anyway invited to effect a proper waste separation, in order to facilitate the recycling of the materials of which the packing is composed.

I-2 PRELIMINARY CHECKS

Check that there has been no damage to the pump during transportation or storage. Both inlet and outlet ports should be carefully cleaned removing possible dust or residual packaging material. Verify that the available electrical power supply corresponds to the pump specification requirements.

I-3 POSITIONING OF THE PUMP

The pump can be mounted in any position. Fix the pump utilizing suitable screws corresponding to the antivibration mounts supplied with the pump.

WARNING: THE PUMP MOTOR IS NOT EXPLOSION PROOF. Do not install the pump where flammable vapours or gases may be present. Install the pump in an accessible place for inspection.

It is good practice to avoid any pump contact with water splashes possibly causing water seepage into the motor with high risk of internal oxidation and/or short circuit.

TUBING CONNECTIONS

I-4

Prior to making any tube/hose connections, check that the inlet ports have no end caps. Do not position the pump at a height greater than 3 m with respect to the minimum level of the fluid to be transferred. Pump damage may occur if this height is exceeded as the pump may not draw fluid. Make sure that the outlet tube is empty and without chokes.

Avoid choking the inlet or outlet tubes so that pump efficiency is optimized. The use of an inlet filter is mandatory especially with fluids containing impurities (filter grid gauge 0,5 mm, ASTM mesh no.35). In this case frequent cleaning and maintenance of the filter is advisable. Utilize tubes and connection pieces that are resistant to the fluid types handled and avoid any possible environmental dispersion.

PUMP INSTALLATION

I-5

The electrical installation of the pump must include a protection fuse which is suitably rated as indicated on the motor label.

WARRANTY EXPIRES IF NO FUSE IS UTILIZED

Always mount the anti vibration rubber fittings supplied with the pump kit. Their usage ensures a consistent reduction in noise and vibration levels.

Electrical cabling size should depend on the distance between pump and battery power supply.

Up to 4 m: 4 mm²

The use of undersized cabling can cause overheating of the electrical wiring and subsequent fire hazard. There will also be a voltage drop at the motor terminals with a consequent reduction in efficiency.

The flow rate value indicated on the motor label is obtained with a 16 mm internal tube diameter. Tubes with inferior diameters will cause an increase in current with potential risk of motor overheating. On the outlet side it is advisable to use at least a short section of flexible tubing, and an accumulator tank for greater efficiency of the system. When starting the pump slightly open the small valve located next to the pressure switch, in order to let the air out and facilitate the pump priming. As soon as the pump is operating close the small valve.

To ensure the correct directional flow of the fluid as indicated by the arrow on the top of the pump, it is necessary to connect the positive pole of the battery supply to the red wire (+) on the motor end-cap and the negative pole to the black wire (-). Electrical connections must be made using adequate terminal blocks and connectors ensuring a tight fitment of the electrical cables. Bad wiring can cause power losses and/or overheating of the cabling itself.

WARNING: it is the responsibility of the installation technician to ensure a correctly designed circuit installation fitted according to regulations. Environmental risks must be taken into account with the installation.

L

TROUBLESHOOTING

L-1

CHECK POINTS IF THE PUMP HAS STOPPED OR WILL NOT START

- Check the effectiveness of the battery power supply (voltage activity)
- Check if the fuse has blown
- Check for any foreign matter present in-between the pump gear drives. To do this, disconnect the power supply and unscrew the four fixing screws, remove the pump front cover plate and inspect the pump chamber. Replace the cover plate in the same initial position after inspection.
- Avoid running the pump dry for more than a few minutes. Pumps found defective that have run dry in the absence of fluid are not covered by warranty.
- The average life span of the motor commutator brushes is approximately 1500 hours under normal operating conditions. Stoppages are possible due to brush wear and tear after such a time period.

L-2

WHY THE PUMP WILL NOT PRIME ITSELF?

- The pump is fitted at a height greater than 3 m above the fluid level.
- The pump has run dry for too long a period
- Long periods of inactivity. In this case it is advisable to add liquid directly into the pump chamber before start-up. It is also advisable to add, before running the pump, a drop of lubricating oil inside the pump only.
- Air leak at the suction pipe due to the following reasons:
 - Possible cuts in the pipe, inadequate hose clamps, malfunctioning of the filter due to defective/worn seals or filter clogged.
- Air leak at the pump front plate cover due to the following reasons:
 - Loose fixing screws, poor effectiveness of the seal.
- Faulty electrical cable connections
- Presence of obstructions or restrictions in the suction or delivery pipes or the use of special devices(eg. automatic spray pistol or aqua-stop).
- Presence of liquid loops in the outlet tube.

L-3

GOOD PRACTICES ENSURING A WELL FUNCTIONING PUMP

No particular maintenance is required if the pump is utilized for the transfer of diesel fluids. If it is expected that the pump will not be used for a period of at least 30 days, especially in the case of usage with fresh or salty water, it is advisable to run fresh water through the pump and to then loosen the pump front plate screws.

Upon re-use, run the pump briefly (a few seconds) and then tighten the screws again. Check under conditions of maximum operating pressure that the motor current value is within the motor label specifications.

NORMAL MAINTENANCE

L-4

- Check frequently and keep the inlet filter clean.
- Check every month the pump chamber and keep clean from any foreign matter.
- Check every month that electrical wiring is in good condition.
- Every 1500 hours of pump operation substitute the motor brushes.
- Every season check the mechanic of the pressure switch and keep it lubricated

INDICATORS THAT THE PUMP IS FUNCTIONING CORRECTLY

L-5

- Temperature of pump body and motor frame is within 60°C - 70°C
- Regular flow and constant pump noise levels
- Amp-draw within the limits indicated in the technical details.

TO OPEN THE PUMP

L-6

It is recommended that a specialized service technician be consulted for any pump repair work or the replacement of worn out internal components, exclusively with original spare parts.

During the warranty period, only by authorized Marco S.p.A. personnel, failing which the warranty will expire.

ENVIRONMENTAL DISPOSAL

M

For a correct disposal of the pump at the end of its life, contact the local waste disposal service. The proper waste separate collection helps avoiding possible negative effects on the environment and on everybody's health. It also facilitates the recycling of the materials of which the product is composed.

WARRANTY

N

- 1) The Warranty period is 2 years from date of purchase on production of the appropriate sales invoice.
- 2) Should the original sales invoice not be available, then the 2 year warranty period will be valid from date of production.
- 3) The Warranty becomes null and void in the case of incorrect utilization or disregard of the instructions contained herein.
- 4) The Warranty only covers original production defects.
- 5) The Warranty does not cover any related installation costs involved.
- 6) Transport costs are refundable only in the case where warranty has been duly recognized and accepted by Marco Spa. These costs will be limited to the actual shipment costs between Marco Spa warehouse and the client's delivery address.
- 7) No credit notes or replacement items will be issued prior to the receipt and proper Testing of any Marco goods that are deemed faulty.

EXPLODED VIEW

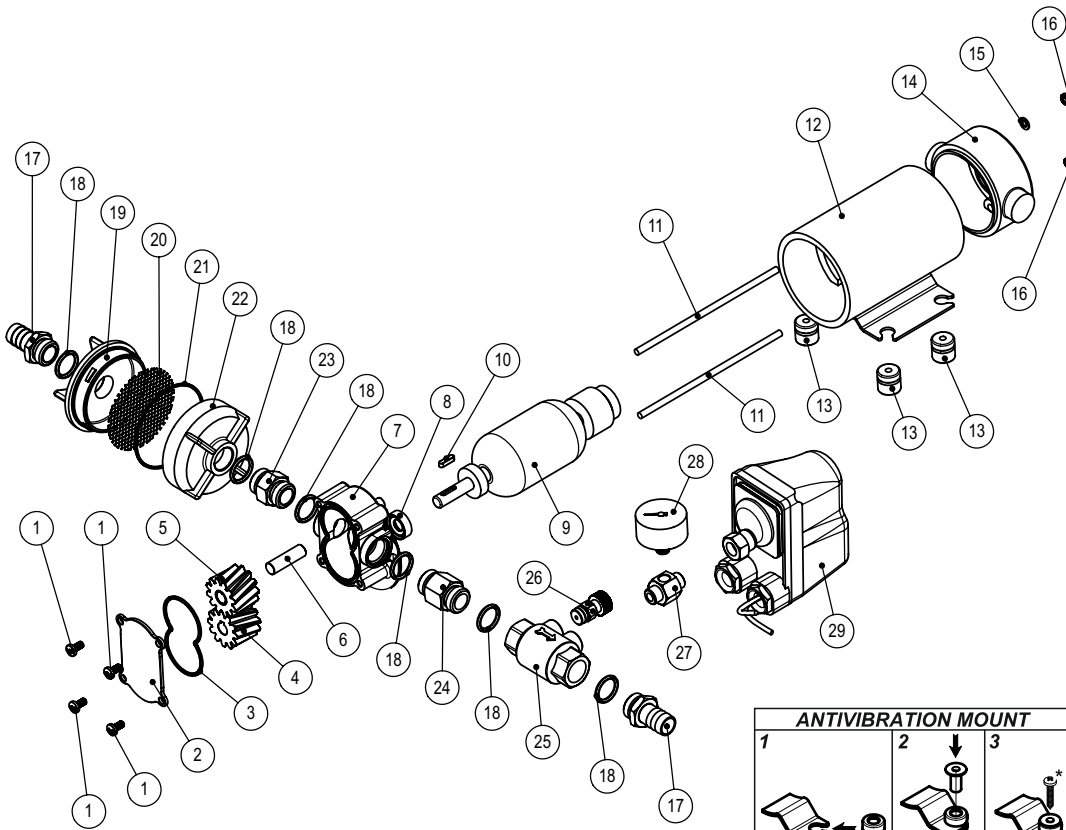

ART.	Q.TY	DESCRIPTION
1	4	TOP PLATE SCREW M 5 X 10
2	1	TOP PLATE
3	1	TOP PLATE O-RING
4	1	DRIVING GEAR
5	1	IDLE GEAR
6	1	IDLE SHAFT
7	1	PUMP BODY
8	1	RUBBER LIP SEAL
9	1	ARMATURE
10	1	KEY
11	2	ROD
12	1	PUMP FRAME WITH MAGNETS
13	4	ANTIVIBRATION MOUNT
14	1	BRUSH HOLDER
15	2	WASHER
16	2	NUT
17	2	TUBE OUTLET
18	6	O-RING
19	1	FILTER HOUSING (MALE)
20	1	FILTER NET
21	1	FILTER O-RING
22	1	FILTER HOUSING (FEMALE)
23	1	NIPPLE 1/2 "
24	1	LONG NIPPLE 1/2 "
25	1	NON RETURN VALVE
26	1	AIR VENT VALVE
27	1	NIPPLE FOR PRESSURE-GAUGE
28	1	PRESSURE-GAUGE
29	1	PRESSURE SWITCH

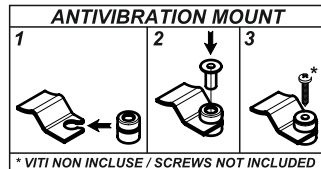

DIMENSIONS

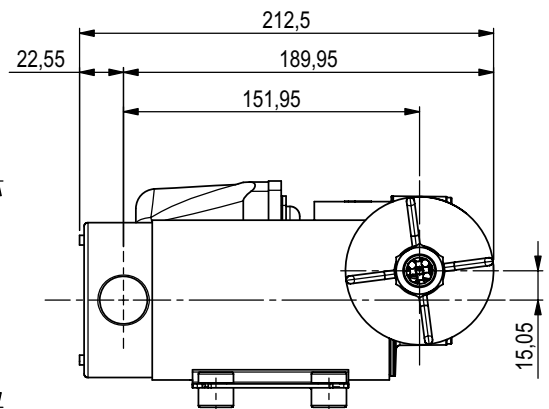
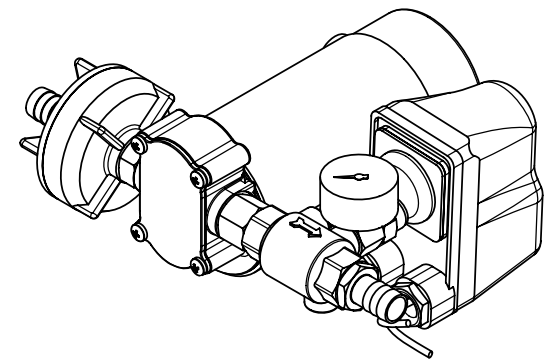
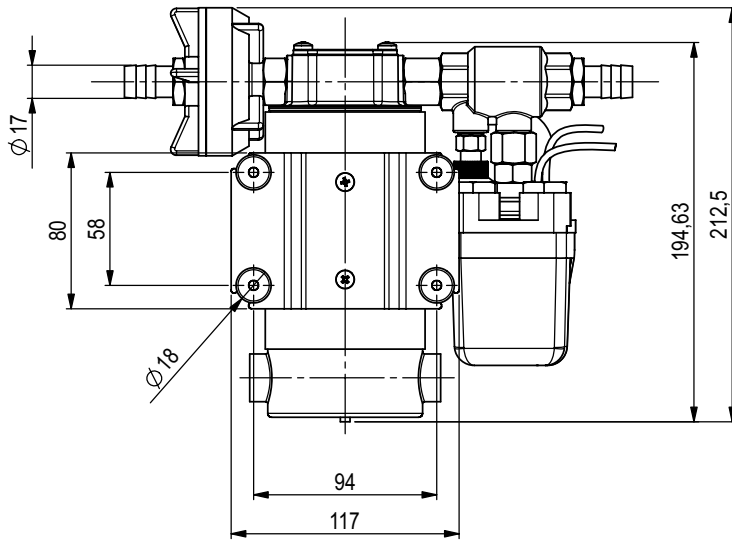

FLOW RATE DIAGRAM

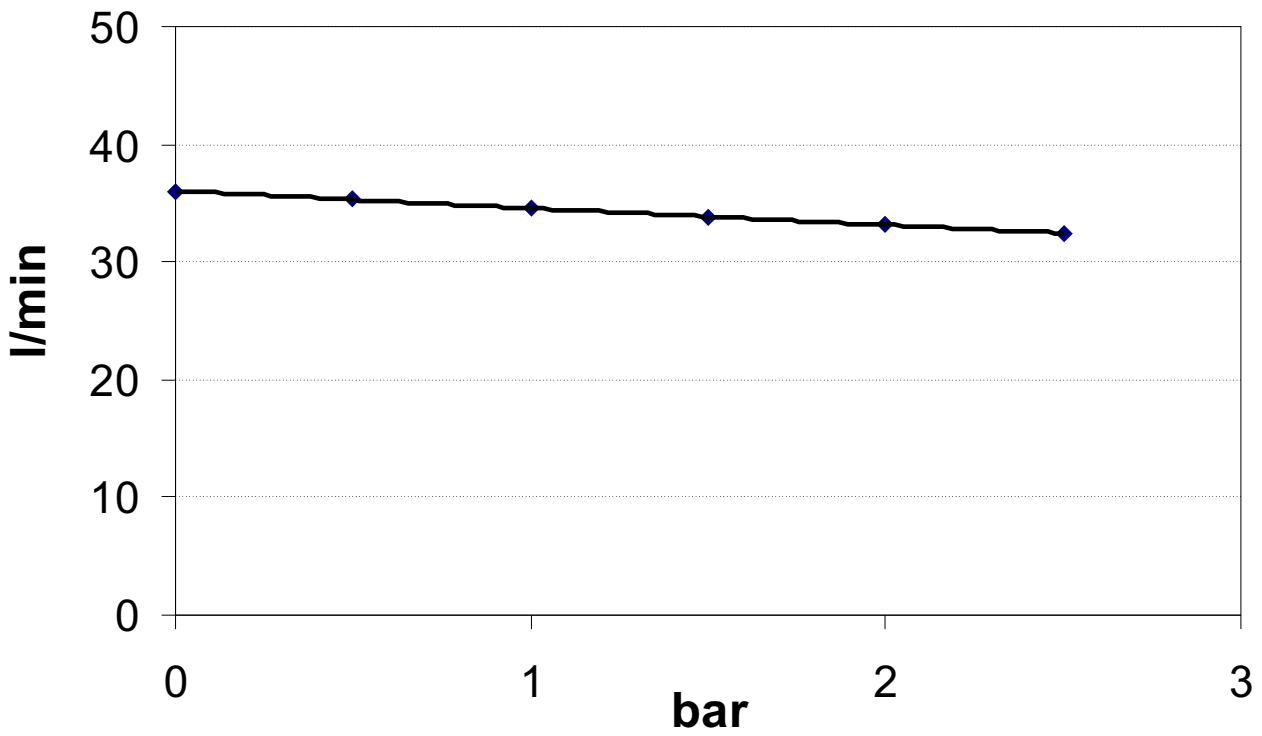

AMPERE-DRAW DIAGRAM

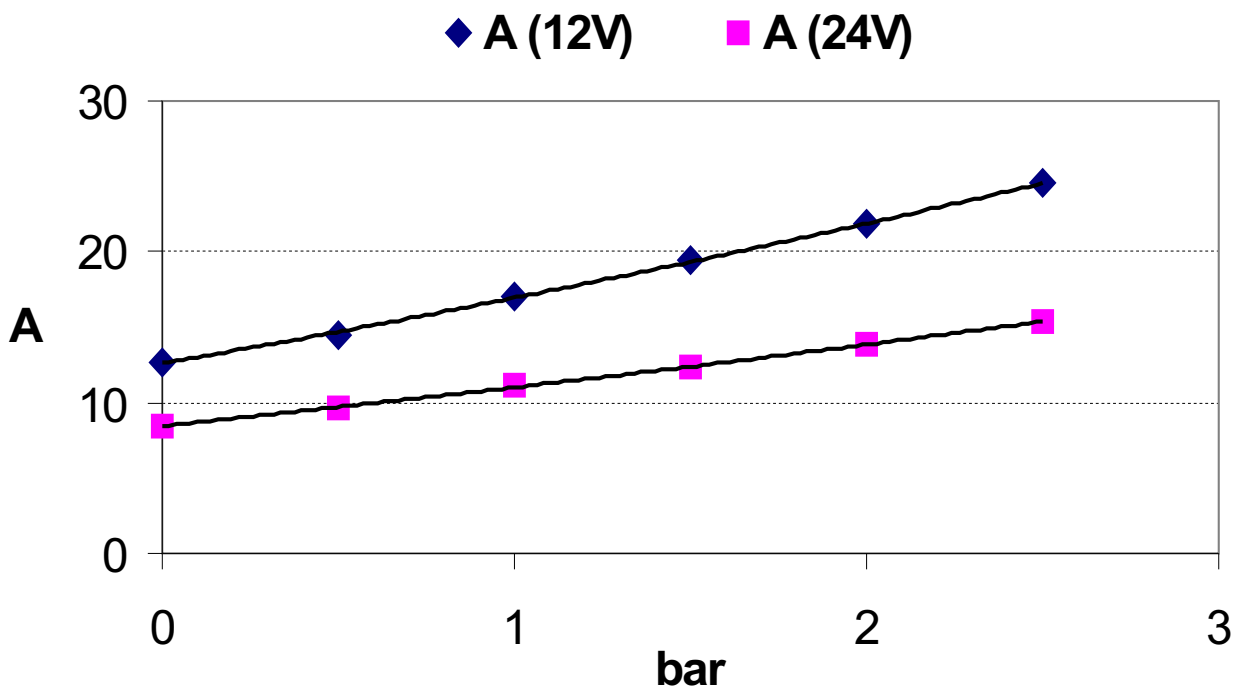

MARCO PUMPS LIST

ITEM	DESCRIPTION
1620011C	UP1 220V a.c. rubber impeller pump 30 l
16200012	UP1 12V rubber impeller pump 35 l
16200013	UP1 24V rubber impeller pump 35 l
16200212	UP1-N 12V rubber impeller pump 35l
16200213	UP1-N 24V rubber impeller pump 35l
16420012	UP2 12V gear pump 8 l
16420013	UP2 24V gear pump 8 l
16466015	UP2/A 12/24V automatic pump with electronic pressure switch 8 l
16422012	UP2/OIL 12V gear pump for lubricating oil
16422013	UP2/OIL 24V gear pump for lubricating oil
16420212	UP2/P 12V PTFE gear pump 8 l
16420213	UP2/P 24V PTFE gear pump 8 l
16420412	UP2-PV 12V PTFE gear pump 8 l + non-return valve
16420413	UP2-PV 24V PTFE gear pump 8 l + non-return valve
1640031C	UP3/AC 220V 50Hz oil / diesel gear pump 10 l
1640011C	UP3/AC 220V a.c. gear pump 10 l
16400012	UP3 12V gear pump 14 l
16460215	UP3/E 12/24V automatic pump with electronic pressure switch 14 l
16400013	UP4 24V gear pump 14 l
16400212	UP3/P 12V PTFE gear pump 14 l
16400213	UP4/P 24V PTFE gear pump 14 l
16402012	UP3/OIL 12V gear pump for oil
16402013	UP4/OIL 24V gear pump for oil
16460012	UP3/A 12V automatic pump group with accumulator
16460013	UP4/A 24V automatic pump group with accumulator
1640621C	UP6/AC 220V a.c. gear pump 28 l
1640611C	UP6 220V a.c. gear pump 28 l
16406012	UP6 12V gear pump 26 l
16406013	UP6 24V gear pump 26 l
16408012	UP6/OIL 12V gear pump for oil
16408013	UP6/OIL 24V gear pump for oil
16462012	UP6/A 12V automatic pump group with accumulator
16462013	UP6/A 24V automatic pump group with accumulator
16410212	UP9-PN 12V internal brushes PTFE gear pump
16410213	UP9-PN 24V internal brushes PTFE gear pump
16410012	UP9 12V heavy duty gear pump
16410013	UP9 24V heavy duty gear pump
16464012	UP9/A 12V heavy duty automatic pump group with accumulator
16464013	UP9/A 24V heavy duty automatic pump group with accumulator
16440012	UP10 12V bronze gear pump 18 l
16440013	UP10 24V bronze gear pump 18 l
16440212	UP10/P 12V PTFE gear pump 18 l
16440213	UP10/P 24V PTFE gear pump 18 l
16468012	UP12/A 12V water pressure pump system
16468013	UP12/A 24V water pressure pump system
16432012	UP12/OIL 12V bronze gear pump 15 l
16432013	UP12/OIL 24V bronze gear pump 15 l
16430012	UP12 12V gear pump 40 l
16430013	UP12 24V gear pump 40 l

ITEM	DESCRIPTION
16430212	UP12/P 12V PTFE gear pump 40 l
16430213	UP12/P 24V PTFE gear pump 40 l
1640421C	UPX 220V a.c. gear pump 10 l stainless-steel version
16404012	UPX 12V gear pump 14 l stainless-steel AISI 316
16404013	UPX 24V gear pump 14 l stainless-steel AISI 316
1640431C	UPX-C 220V a.c. stainless-steel gear pump for chemicals 10 l
16404112	UPX-C 12V stainless-steel gear pump for chemicals 14 l
16404113	UPX-C 24V stainless-steel gear pump for chemicals 14 l
16410112	UP9-XC 12V heavy duty gear pump - s.s. AISI 316
16410113	UP9-XC 24V heavy duty gear pump - s.s. AISI 316
16440112	UP10-XC 12V heavy duty gear pump - s.s. AISI 316 - 18 l
16440113	UP10-XC 24V heavy duty gear pump - s.s. AISI 316 - 18 l
16490015	SP2 12/24V shower pump
16480012	DP3 12V deck washing pump
16480013	DP3 24V deck washing pump
16482012	DP9 12V deck washing pump
16482013	DP9 24V deck washing pump
16484012	DP12 12V deck washing pump
16484013	DP12 24V deck washing pump
16010012	UP500 12V bilge pump
16010013	UP500 24V bilge pump
16012012	UP1000 12V bilge pump
16012013	UP1000 24V bilge pump
16014012	UP1500 12V bilge pump
16014013	UP1500 24V bilge pump
16016012	UP2000 12V bilge pump
16016013	UP2000 24V bilge pump



Associazione AIB
associazione
industriale
bresciana

DICHIARAZIONE DI CONFORMITA' C.E. E.C. DECLARATION OF CONFORMITY

Confermiamo che il prodotto:
We confirm that the product:

164 680 13 - UP12/A 24V pompa ad ingranaggi 36 l / gear pump

E' conforme alla Direttiva 2004/108/CE (ex.89/336/CE) relativa alla compatibilità elettromagnetica.
is in conformity with the Directive 2004/108/EC (ex.89/336/EC) relating to electromagnetic compatibility.

Questa dichiarazione è valida per tutti gli articoli prodotti secondo la documentazione tecnica che è parte di questa dichiarazione. In caso di eventuali verifiche pertinenti alla Compatibilità Elettromagnetica sono state applicate le seguenti normative:

This declaration is valid for all products which are produced in accordance with the technical documentation which is a part of this declaration. For verification of conformity with regard to Electromagnetic Compatibility the following standards are applied:

EN 55014-1

Compatibilità elettromagnetica.
Requisiti per gli elettrodomestici,
gli utensili elettrici e apparecchi simili.
Parte 1: Emissione.

*Electromagnetic compatibility.
Requirements for household appliances,
electric tools, and similar apparatus.
Part 1: Emission.*

Questa dichiarazione è rilasciata sotto la responsabilità esclusiva di:

This declaration is given under the sole responsibility of:

MARCO S.P.A.
Via Mameli 10 - 25014 Castenedolo - Brescia - Italy
Tel. 030/2134.1 Fax 030/2134.300

Questo documento e' proprieta' di Marco S.p.A la riproduzione e l'uso sono vietati.
Tutti i diritti sono riservati.

Per ulteriori informazioni vedere nostro sito internet - www.marco.it
Marco S.p.A Via Mameli 10 - 25014 Castenedolo (Brescia) – Italia
tel. +39 030 2134.1 / Fax +39 030 2134.300

Property of MARCO S.p.A reproduction prohibited. All rights reserved.
For further information visit our web site - www.marco.it
Marco S.p.A Via Mameli 10 - 25014 Castenedolo (Brescia) – Italy
tel. +39 030 2134.1 / Fax +39 030 2134.300