

- ABMESSUNGEN  
mm [Zoll]  
\* kann bei anderen Motorfabrikaten abweichen

- DIMENSIONS  
mm [Inch]  
\* may change with different motor manufacturer

- ANSCHLÜSSE  
Losflansch DN25 PN10/16 - PP-ST oder G1" Innengewinde  
Saug- und Druckseite abhängig von Drehrichtung.  
Pumpe kann reversibel eingesetzt werden.

- CONNECTIONS  
Loose Flange DN25 PN10/16 - PP-ST or threaded G1" female  
Suction and discharge side depends on direction of rotation.  
Pump is reversible.

- ANTRIEB  
Drehstrom-Asynchronmotor mit Käfigläufer  
Baugröße / Form: BG90 B5  
Fabrikat: VEM

- DRIVE  
TEFC three phase asynchronous squirrel cage electric motor  
Size: IEC 90 B5  
Type: VEM

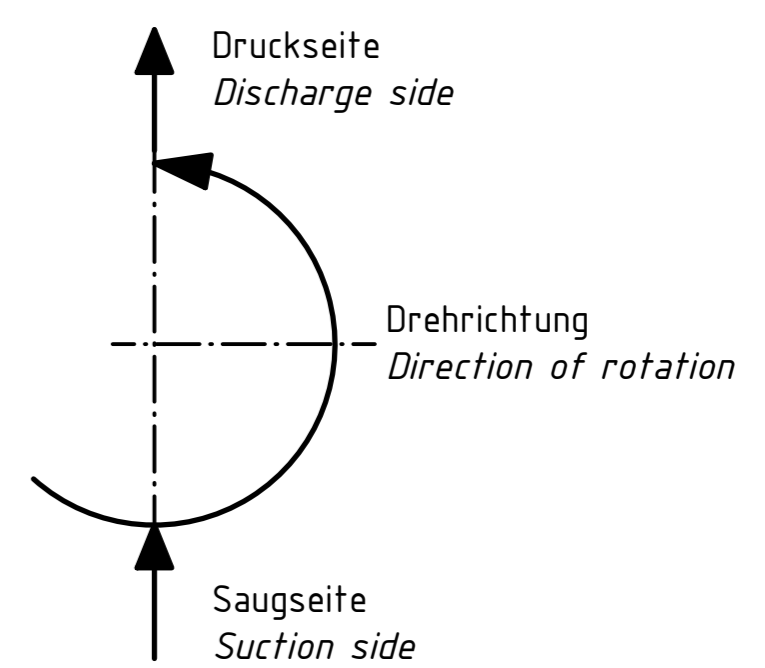
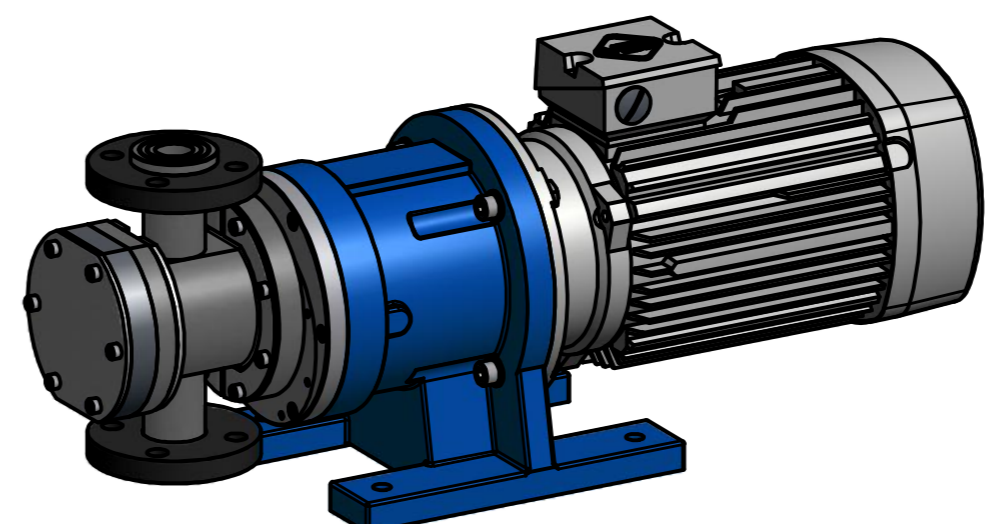
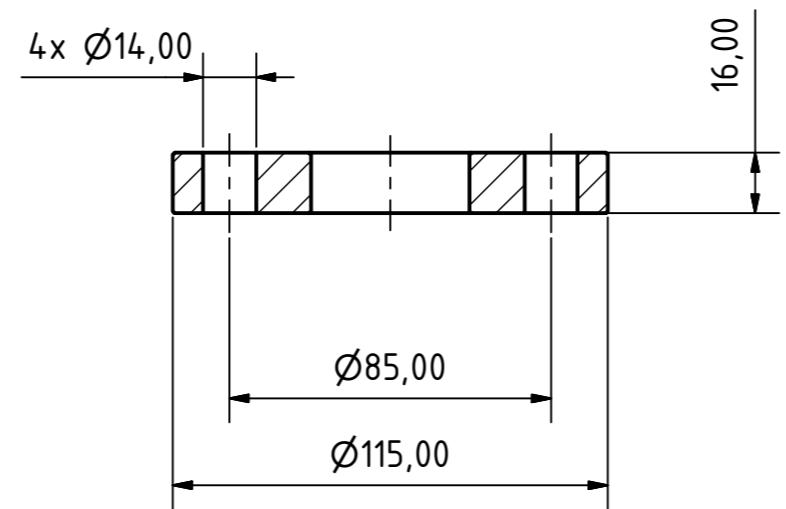
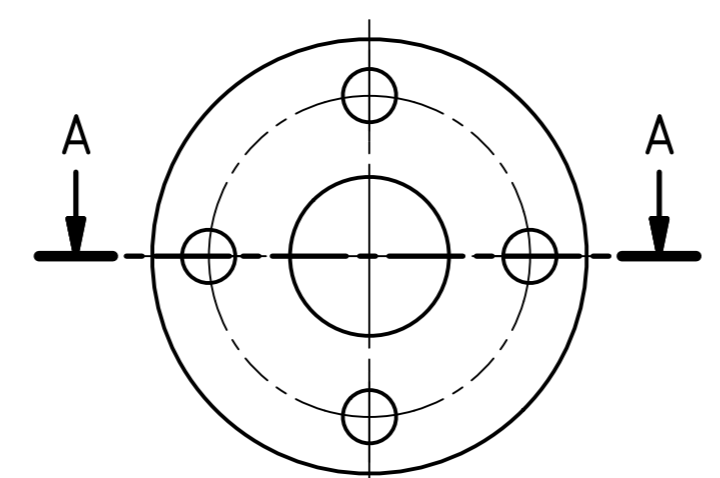

Alle Angaben unverbindlich, technische Änderungen vorbehalten! Technical data not binding and subject to change!  
Copyright MARCH PUMPEN GmbH 2016

		MARCH PUMPEN GmbH & Co.KG Rätthausstraße 2 D-35394 Gießen info@march-pumpen.com www.march-pumpen.com			1:2	
		Datum	Name	TEF-MAG 1500 P-F-V BG90 B5 VEM ABMESSUNGEN DIMENSIONS DRAWING_TM-1500-P-F-V-IEC90-VEM		
		Gezeichnet	Lach			
		Kontrolliert				
		Norm				
Status	Änderungen	Datum	Name			