



MARCH PUMPS

1819 PICKWICK AVE., GLENVIEW, IL 60026-1306, U.S.A
 PHONE: (847) 729-5300 - FAX: (847) 729-7062
 WWW.MARCHPUMP.COM

DESCRIPTION: Series 5 are centrifugal magnetic drive pumps, eliminating the need for a shaft seal. All are serviceable with a screwdriver.

OPERATION: Pumps are not self-priming, lack a suction lift, and thus require a flooded suction. Pumps cannot be run dry because the impeller requires the liquid being pumped for lubrication. For liquids with a specific gravity greater than water, have a higher viscosity, or for elevated temperatures, a trimmed impeller may be necessary. For application assistance, contact March Pump.

ELECTRICAL: Models are dual voltage 115/230V for 60hz and 110/220V 50hz. The standard motor has a conduit box. A motor with 115V 72 inch cord or 230V 72 inch cord, are options. The motor is U.L. listed motor and rated for continuous duty. The pump is rated IP44. The pump is Ignition Protected per SAE J1171 and ISO 8846.

CE: Pumps marked with CE have been modified to be listed as CE. Contact March for more information.

TE-5M-MD and TE-5MNS-MD Marked with CE

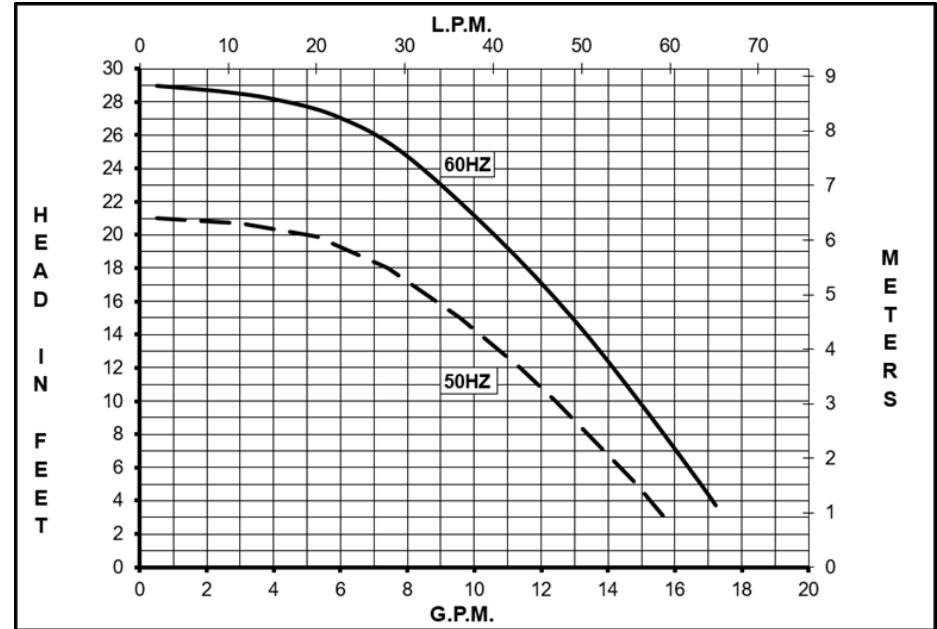

Specifications		TE-5M-MD Marked with CE	TE-5MNS-MD Marked with CE
Product	1Ph	0150-0265-0100	0150-0268-0100
With 115V Cord	1 Ph	0150-0266-0100	0150-0269-0100
With 230V Cord	1 Ph	0150-0267-0100	0150-0270-0100
Inlet-Outlet		1" FPT-1/2" MPT	1" FPT-1/2" MPT
Max Internal Pressure		50PSI (344 kPa)	50PSI (344 kPa)
Max Liquid Temperature		190F (87C)	190F (87C)

Model	60Hz												50Hz										
	Max Flow		Max Head			Electrical							Max Flow		Max Head			Electrical					
	GPM	LPM	FT	PSI	M	Ph	V	A	HP	kW	RPM	GPM	LPM	Feet	PSI	M	Ph	V	A	HP	kW	RPM	
TE-5M-MD	18	68.1	29	12.6	8.85	1	115/230	2.6/1.3	1/5	0.149	3450	15.9	60.5	20.7	8.96	6.3	1	110/220	2.4/1.2	0.16	0.119	2850	
TE-5MNS-MD	18	68.1	29	12.6	8.85	1	115/230	2.6/1.3	1/5	0.149	3450	15.9	60.5	20.7	8.96	6.3	1	110/220	2.4/1.2	0.16	0.119	2850	

All specifications & data are based on pumping water & are intended as a guideline only. Specifications may vary with different motors.

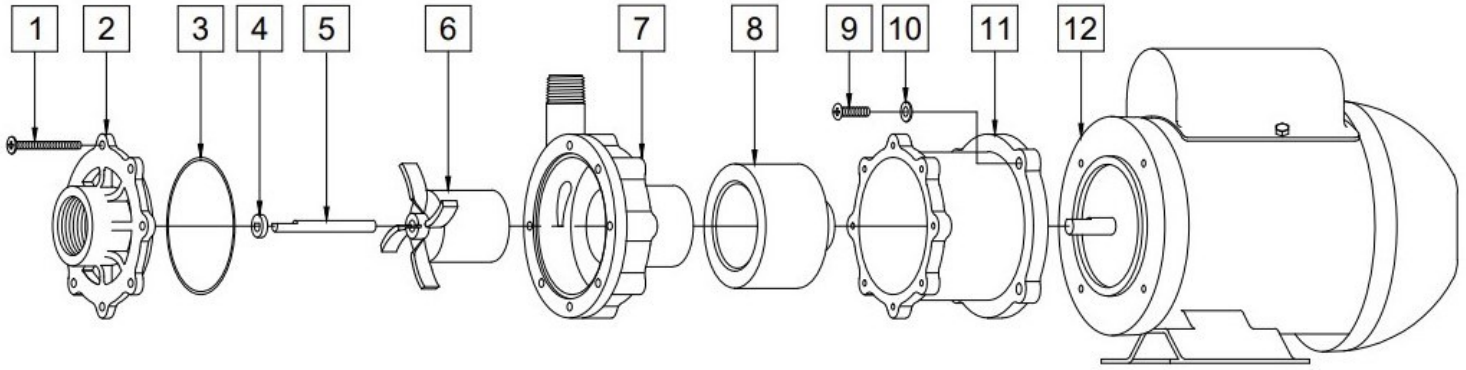

NOTE: When attaching the Drive Magnet to the motor shaft, position the face of the Drive Magnet 3/32 inch below the face of the Motor Bracket.

TE-5M-MD Marked with CE

TE-5MNS-MD Marked with CE

Item	Part Number	QTY REQ	Description	Item	Part Number	QTY REQ	Description
1	0150-0021-1000	7	#8-32 x 1-3/4 LG Screw (Stainless)	1	0150-0021-1000	7	#8-32 x 1-3/4 LG Screw (Stainless)
2	0150-248-1000	1	Cover with 1" FPT Inlet (Noryl)	2	0150-248-1000	1	Cover with 1" FPT Inlet (Noryl)
3	0750-0987-1000	1	0.078 CS x 2.834 ID O-Ring (Buna N)	3	0750-0987-1000	1	0.078 CS x 2.834 ID O-Ring (Buna N)
4	0130-0028-1000	1	Thrust Washer (Ceramic)	4	0130-0028-1000	1	Thrust Washer (Ceramic)
5	0130-0176-1000	1	3 Flat Shaft (316 Stainless Steel)	5	0130-0176-1000	1	3 Flat Shaft (316 Stainless Steel)
6	0150-0030-0700	1	Impeller with Carbon Bushing(Polypropylene, Carbon, Ceramic Magnet)	6	0150-0030-0700	1	Impeller with Carbon Bushing(Polypropylene, Carbon, Ceramic Magnet)
7	0150-0031-0100	1	Rear Housing with 1/2" MPT Outlet and Ceramic Thrust Washer (Polypropylene/Ceramic)	7	0150-0110-0010	1	Rear Housing with 1/2" MPT Outlet (316 Stainless Steel)
8	0150-0176-0300	1	Drive Magnet	8	0150-0176-0300	1	Drive Magnet
9	0150-0050-1000	4	#10-32 x 3/4 LG. Screw (Stainless)	9	0150-0050-1000	4	#10-32 x 3/4 LG. Screw (Stainless)
10	0150-0051-1000	4	#10 Washer (Stainless)	10	0150-0051-1000	4	#10 Washer (Stainless)
11	0150-0070-0100	1	Motor Bracket (Plastic)	11	0150-0070-0100	1	Motor Bracket (Plastic)
12A	0150-0213-1000	1	Motor (Weg), TEFC, 115/230V, 50/60Hz	12A	0150-0213-1000	1	Motor (Weg), TEFC, 115/230V, 50/60Hz
12B	0150-0272-0100	1	Motor (Weg), TEFC, 115V 72 Inch Cord, Marked with CE	12B	0150-0272-0100	1	Motor (Weg), TEFC, 115V 72 Inch Cord, Marked with CE
12C	0150-0273-0100	1	Motor (Weg), TEFC, 230V 72 Inch Cord, Marked with CE	12C	0150-0273-0100	1	Motor (Weg), TEFC, 230V 72 Inch Cord, Marked with CE

NOTE: Contact Factory for other materials and/or parts not listed.

Special voltage motors are available upon special order.

Materials in contact with the liquid: TE-5M-MD : Polypropylene, Noryl, Buna N, 316 Stainless Steel, Carbon, Ceramic, Ceramic Magnet.

TE-5MNS-MD: Polypropylene, Noryl, Buna N, 316 Stainless Steel, Carbon, Ceramic, Ceramic Magnet.

LIMITED WARRANTY: March pumps are guaranteed only against defects in workmanship or materials for a period of one year from date of manufacture pumping water. For the complete warranty and to register online go to www.marchpump.com/warranty-registration

For the General Installation Manual, see this link <https://www.marchpump.com/wp-content/uploads/2019/07/march-pump-general-installation-guide-0750-040.pdf>

Or scan QR Code





MARCH PUMPS

1819 PICKWICK AVE., GLENVIEW, IL 60026-1306, U.S.A

PHONE: (847) 729-5300 - FAX: (847) 729-7062

WWW.MARCHPUMP.COM



Safety Instructions & Preventive Maintenance

Read this sheet and the appropriate pump instruction manual before installing and operating any pump. Failure to follow safety instructions may result in injury or death.

Health Precautions

These pumps utilize magnets. Any individuals with pacemakers, implanted defibrillators, electronic medical devices, metallic heart valves, or sickle cell anemia should consult a health care professional before working with these pumps.



Motor may become hot, exercise caution before touching. Allow the motor to cool down for a sufficient amount of time before attempting any maintenance or handling to prevent burns or injuries. Install pump in a well-ventilated area to facilitate heat dissipation and reduce the risk of overheating.



The motor has the potential to present an electrical hazard. Prior to any maintenance or handling, ensure power to the motor is OFF. If there is uncertainty about the electrical safety of the motor, consult with a qualified electrician before proceeding with any maintenance/repairs.



Pumps may be heavy, use caution when lifting and/or relocating a pump.

Unpacking

Unpack the pump and/or parts and check for signs of shipping damage. If damage is detected take pictures and contact the carrier. Check that all ordered parts are included.

Remove all labels and stickers from all wet end part surfaces that come into contact with the liquid (impeller, shaft, thrust washer, housing(s), etc...). Do not remove labels on the motor, and/or exterior of the pump. Do not remove labels from the exterior of marine pumps.

For stainless steel pumps, the impeller, thrust washer, and shaft are packed separately.

Installation/Operation Precautions

Installation of Complete Pump

Pumps should be securely fastened. Install the motor per local and national electrical codes. Always ground the pump motor. Only use the specified voltage listed on the nameplate, do not operate the pump with a different voltage than specified on the motor nameplate. Do not exceed the service factor of the motor. Do not cover the motor. Check all electrical connections with the wiring diagram found on the motor.

Most March Pumps are not self-priming pumps. Liquid must flow naturally to the pump. Do not operate the pump until liquid is inside of the pump. **Never run the pump dry.**

If the pump is in a hazardous environment, utilize an appropriate explosion-proof motor.

Do not submerge the pump unless it is a submersible pump.

For further instructions, see [March General Installation Guide](#).

Operation

The pump has moving parts when in operation. Follow local safety standards for locking out the motor during assembly or disassembly.

The pump may be used for transferring various chemicals. Always wear appropriate person protective equipment (including protective eye care, gloves, clothing, etc.) and follow safety procedures during operation of pump. Procedures should be in place for draining and decontamination of pump before disassembling or inspecting the pump.

Do not operate with a closed suction or discharge valve. Do not start with a closed suction valve.

The wet end and/or motor may become hot during operation.

Always check with a March Manufacturing representative before pumping any liquid with solids.

Maintenance

March Manufacturing has not established a general preventive maintenance schedule for its line of pumps, as each application presents its own specific conditions. The pump should be checked upon installation, first use, and monitored for one week. If any abnormality is detected concerning vibration, noise, electric current, flow or head rate, turn off the pump immediately and inspect individual parts.

The pump should be periodically inspected for wear on the impeller bushing. The frequency of the inspection should be determined by the customer.

Follow motor lubricating oil instructions as found on motor label. (Not every motor requires lubrication)

Bolts may loosen after extended running. Tighten bolts if loose.

Remove excessive dust or particles from motor.

Do not clean exterior of pump or motor with any flammable solvents.

Assembly/Disassembly

Magnets

Magnets on specific models may be strong enough to pull the wet end and motor end quickly together during assembly or disassembly.

WARNING: Do not put fingers between the two mating surfaces (between impeller magnet and/or impeller vanes and the rear pump housing) during assembly or disassembly, especially for the 7.5, 8, and 10 Series. Magnets may attract tools, use caution.

Assembly

Contact March Manufacturing for proper assembly procedure concerning drive magnet and motor bracket.

Exercise caution in removing impellers on all models but especially on the 7.5, 8, and 10 Series due to the strong magnetic forces between the impeller magnet and drive magnet. When handling impeller hold onto the outer diameter of the impeller vanes with both hands and gently engage the impeller into the magnet field. Hold the impeller firmly to resist the magnetic attraction. Keep magnets away from and free of any metal chips and particles.

Do not overtighten fasteners. Contact March Manufacturing for appropriate torque levels.

Care must be taken that the "O" Ring sits in the groove appropriately. Do not pinch or nick the O-Ring.

Before connecting power, rotate the motor fan to ensure there is no binding or rubbing of the drive magnet against the rear housing.

Disassembly

Disconnect power from the pump and drain the pump.

See "Draining the Pump" section below.

After draining, separate front housing/cover from rear housing. Ensure that no liquid is remaining on the parts.

Separate the parts. Exercise caution in removing impellers on all models -- but especially on the 7.5, 8, and 10 Series -- due to the strong magnetic forces between the impeller magnet and drive magnet. When handling impeller hold onto the outer diameter of the impeller vanes with both hands and extract the impeller from the rear housing. Hold the impeller firmly to resist the magnetic attraction as you remove the impeller. Keep magnets away from and free of any metal chips and particles.

If any part appears damaged or defective, take pictures and contact a March Distributor or March Manufacturing.

Individual parts are listed on the appropriate pump manual.

Shut Down Procedure

1. Disconnect the power/turn off motor.
2. Carefully close the discharge valve.
3. Close suction valve.

*Caution must be exercised with automated valves.

Draining the Pump

1. Wear appropriate safety gear.
2. Disconnect the power.
3. Close suction and discharge valves.
4. Remove pipe/hose/tube from suction and discharge.
5. Unscrew/untighten fasteners from wet end.
6. Direct outlet downward into appropriate container.

NOTE: Observe local laws and regulations for handling and disposing hazardous liquids. Do not get motors wet. Not all motors are dust proof or submersible proof.

Other

For further information on temperature ratings, pressure ratings, horsepower, and NPSHr, utilize the pump's specific pump manuals and performance curves, which can be found on www.marchpump.com

Always follow the recommendations of March Manufacturing's [Chemical Resistance Guide](#) unless specified otherwise by a March Manufacturing representative.

Troubleshooting

General Notes

- Liquids containing ferrous metal fines should not be pumped.
- If magnets decouple, stop the pump. Running the pump with the magnets decoupled will weaken the magnets.

Lack of Flow/Head

- Check for air leaks in suction piping.
- Make sure that the pump is primed and not running dry.
- System head higher than anticipated.
- Make sure all valves are open.
- Viscosity or specific gravity is too high.
- Suction lift too high or insufficient NPSH
- System may be clogged.
- Motor rotation incorrect.
- Air in liquid.

Loss of Prime

- Leaks in piping or air in liquid.
- Foot valve problems.
- Foreign objects in liquid.
- Suction lift too high or insufficient NPSHa.

Excessive Power Consumption

- Head lower than rating.
- Too much flow.
- Specific gravity too high.
- Viscosity too high.

Vibration/Noise

- Motor not properly secured.
- Piping not properly secured.
- Pump cavitation from improper suction.
- Drive magnet rubbing against rear housing.

Warranty

Please see Warranty Page on March Website.

www.marchpump.com/warranty-registration