

Electric/Pneumatic Drum and Container Pumps



The ultimate professional solution to all your transfer needs.



Lutz Pumps Inc., Atlanta, Georgia "A Naturalized American".



World Leader since 1962

Lutz introduced the first impeller designed drum pump.

*Lutz Pumps Headquarters,
Atlanta/Georgia, USA*



Drum Pump Technology "Tailor-Made in Germany"

It is always good to know exactly where the product you are investing in comes from. When you invest in a drum or container pump from Lutz you can be sure that your feed-back and specifications plus the close-working relationship of our engineering staff with agencies such as U. L. means that you have the best of two worlds. A quality German product made to high American Standards. The staff at Lutz are chosen specialists who are aware of the responsibility they

carry. They know that the quality of their work is what determines your safety and our success. After almost 30 years of serving the American market and of adapting our products for your specific needs, we naturally feel at home here. With the help of our qualified distributors throughout the United States we look forward to continue giving you a quality product and the service you deserve.

*Production facilities
Wertheim/Germany*

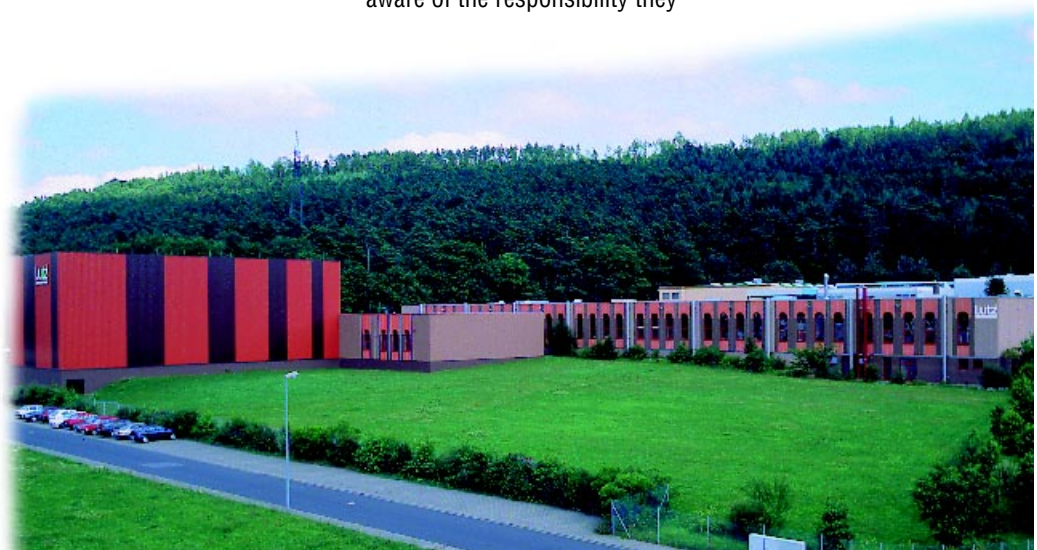

Lutz Drum Pumps today: The Principle with so many useful Variations.



The wide variety of fluids and container types/dimensions necessitates an extensive range of different drum pump models. Depending on the requirement, they are available in a variety of materials, equipped with motors adapted to the output requirement for differing voltages as well as pneumatically operated, with the required

delivery rate and suitable sealing system. Added to this are pump tubes in varying lengths and a wide range of accessories permitting, for example, adaptation to problem containers or application conditions.

Designed specifically for:

Drums, Vats, Totes, Intermediate Bulk Containers (IBC's), Carboys, Open Vessels up to 10' deep.

- Energy efficient
- Portable
- Easy to install, operate, maintain (user-friendly)
- Can last 20+ years
- Safe – an alternative to manual labor – minimize danger of spills, vapors, burns, explosions, health, environmental, liability concerns
- Suitable for flammable liquids with Ex-Motors
- Pulsation free
- Inherent flooded suction
- Sealless or mechanical seal
- Operates by air, electric, or battery motors
- Flow rates to 64 gpm
- Pressures to 36 psi (72 feet of head)
Pressures to 174 psi with progressive cavity models
- Temperatures to 248 °F (up to 284 °F with progressive cavity models)
- Few Parts – maintenance friendly
- 2 Impeller options for most multipurpose models
- Viscosity to 1,500 cps (100,000 cps with progressive cavity models)
- Ex-Motors available (electric or air)
- Variable speed motors available (electric or air)
- Limited run dry capability



Application features typical installation for operation in hazardous locations.

Modular Design: All Lutz Motors are interchangeable with all Lutz Pump Tubes.



Motors

Multi-purpose Pump Tubes – Mechanical Seal (MMS) or Sealless (MSL)

The diagram illustrates the modular design of Lutz pumps, showing how different motors can be paired with various pump tubes. The motors are listed on the left, and the pump tubes are shown on the right, each with its specific material and motor compatibility indicated.

Motor	Pump Tube Material	Motor Compatibility	Model Name
B 28	Polypropylene	MSL-PP, MMS-PP	MSL-PP / MMS-PP
B 36 / MI 4	Polypropylene	MSL-PP, MMS-PP	MSL-PP / MMS-PP
B 55-T / MA II 5	Polypropylene	MSL-PP, MMS-PP	MSL-PP / MMS-PP
B 4/GT	Polypropylene	Mixing Pump Tube in Polypropylene	MP-PP
Silverstar ME I 6	Polypropylene	Mixing Pump Tube in Polypropylene	MP-PP
MD-1/MD-2	Polypropylene	Complete drum drainage in Polypropylene	RE 88 PP
4 GT	Stainless Steel	Mixing Pump Tube in Stainless Steel	MP-SS
MA II 3-12V	Stainless Steel	Complete drum drainage in Stainless Steel	RE 88 SS
	Polyvinylidene fluoride	SL-PVDF, MS-PVDF	SL-PVDF / MS-PVDF
	Aluminum	SL-Alu, MS-Alu	SL-Alu / MS-Alu
	Stainless Steel	SL-SS, MS-SS	SL-SS / MS-SS
	Hastelloy C	MS-HC	MS-HC
	Stainless Steel	Progressive Cavity Pump	DV-SR

Motors and pump tubes are purchased separately

Lutz Drum Pump Motors: Power which is convincing.



B 28

Universal motor
 Power: 800 watt/1.07 HP
 Voltage: 120 volt
 Frequency: 60 Hz
 Enclosure: open drip proof
 16' cord and plug



B 36 / MI 4 or B 36-SC / MI 4 E (speed control)

Universal motor
 Power: 640 watt/0.85 HP
 Voltage: 120 volt
 (220 V available)
 Frequency: 60 Hz
 Enclosure: open drip proof
 16' cord and plug



B 55-T / MA II 5

Universal motor
 Power: 510 watt/0.68 HP
 Voltage: 120 volt
 (220 V available)
 Frequency: 60 Hz
 Enclosure: TEFC
 16' cord and plug



MD 1 (Ex) / MD 2 (Ex)

Compressed air motor
 (EN 50 014)
 Power: 300 watt/0.4 HP
 Operating Pressure: 87 PSI



4GT (Non-Ex)

Compressed air motor
 Power: 220 watt/0.3 HP
 Operating Pressure: 87 PSI



ME I 6 (Ex)

Universal motor
 Power: 620 watt/0.4 HP
 Voltage: 120 volt
 Frequency: 60 Hz
 Enclosure: Explosion proof
 Class I Groups C + D
 Class II Groups F + G
 Variable speed control
 16' cord



MA II 3-12 V

Universal motor
 Power: 260 watt/0.35 HP
 Voltage: 12 volt DC
 Enclosure: TEFC
 10' cord with alligator clamps

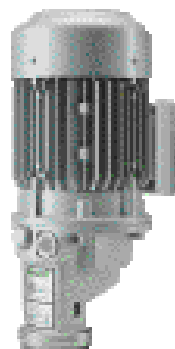







B 4/GT

Three phase gear motor
 Power: 550 watt/0.75 HP
 Voltage: 230/440 volt
 Frequency: 60 Hz
 Enclosure: TEFC or Ex

Technical Data



Pump tubes			MMS-PP 41-R SS/HC	MMS-PP 41-L SS/HC	MSL-PP 41-R SS/HC	MSL-PP 41-L SS/HC	MMS-PVDF 41-R HC	MMS-PVDF 41-L HC	MSL-PVDF 41-R HC	MSL-PVDF 41-L HC	MMS-Alu 41-R
Mechanical Seal (MS) Sealless (SL)			MS	MS	SL	SL	MS	MS	SL	SL	MS
Max. Temperature			122 °F	122 °F	122 °F	122 °F	212 °F	212 °F	212 °F	212 °F	212 °F
Type of impeller			Rotor	Impeller	Rotor	Impeller	Rotor	Impeller	Rotor	Impeller	Rotor
Zone 0			No	No	No	No	No	No	No	No	No
 B 28	Quantity*	Up to GPM	46	23	46	23	43	24	43	24	54
	Delivery head*	Up to FT	33	69	33	69	36	69	36	69	40
	Viscosity**	Up to cps	400	1000	400	1000	400	1100	400	1100	600
	Spec. gravity***	Up to	1.5	2.0	1.5	2.0	1.5	2.0	1.5	2.0	1.5
	Weight lbs.	Motor + pump tube	11.6	11.6	11.6	11.6	11.6	11.6	11.6	11.6	11.6
 B 36	Quantity*	Up to GPM	45	24	45	24	42	24	42	24	54.5
	Delivery head*	Up to FT	31	72	31	72	34	72	34	72	36
	Viscosity**	Up to cps	100	500	100	500	100	600	100	600	100
	Spec. gravity***	Up to	1.1	1.4	1.1	1.4	1.1	1.4	1.1	1.4	1.1
	Weight lbs.	Motor + pump tube	9.1	9.1	9.1	9.1	9.1	9.1	9.1	9.1	9.1
 MA II 5-120 B 55-T-5	Quantity*	Up to GPM	42	21	42	21	38	22	38	22	48
	Delivery head*	Up to FT	26	59	26	59	30	56	30	56	31
	Viscosity**	Up to cps	100	600	100	600	100	700	100	700	100
	Spec. gravity***	Up to	1.2	1.6	1.2	1.6	1.2	1.6	1.2	1.6	1.2
	Weight lbs.	Motor + pump tube	14.6	14.6	14.6	14.6	14.6	14.6	14.6	14.6	14.6
 MD-1/MD-2	Quantity*	Up to GPM	35.5	23	35.5	23	38	22	38	22	53
	Delivery head*	Up to FT	26	39	26	39	30	50	30	50	33
	Viscosity**	Up to cps	600	850	600	850	600	950	600	950	400
	Spec. gravity***	Up to	1.2	1.6	1.2	1.6	1.2	1.6	1.2	1.6	1.2
	Weight lbs.	Motor + pump tube	6.1	6.1	6.1	6.1	6.1	6.1	6.1	6.1	6.1
 4 GT	Quantity*	Up to GPM	29	19	29	19	32	19	32	19	41.5
	Delivery head*	Up to FT	20	33	20	33	22	39	22	39	24.5
	Viscosity**	Up to cps	600	850	600	850	600	900	600	900	400
	Spec. gravity***	Up to	1.2	1.6	1.2	1.6	1.2	1.6	1.2	1.6	1.3
	Weight lbs.	Motor + pump tube	5.1	5.1	5.1	5.1	5.1	5.1	5.1	5.1	5.1
 ME I 6	Quantity*	Up to GPM	×	×	×	×	×	×	×	×	48.5
	Delivery head*	Up to FT	×	×	×	×	×	×	×	×	33
	Viscosity**	Up to cps	×	×	×	×	×	×	×	×	300
	Spec. gravity***	Up to	×	×	×	×	×	×	×	×	1.3
	Weight lbs.	Motor + pump tube	×	×	×	×	×	×	×	×	×
 MA 3-12V	Quantity*	Up to GPM	22	14	22	14	22	14	22	14	39.5
	Delivery head*	Up to FT	13	23	13	23	13	23	13	23	19.5
	Viscosity**	Up to cps	100	600	100	600	100	650	100	650	100
	Spec. gravity***	Up to	1.2	1.8	1.2	1.8	1.2	1.8	1.2	1.8	1.2
	Weight lbs.	Motor + pump tube	12.5	12.5	12.5	12.5	12.5	12.5	12.5	12.5	12.5

*Determined with water at 68 °F.

**Determined with oil.

***Determined with 10 feet hose 3/4" and open nozzle 3/4".
Higher densities possible for shorter operating periods.

× Not a suggested combination



MMS-Alu 41-L	MSL-Alu 41-R	MSL-Alu 41-L	MMS-SS 41-R	MMS-SS 41-L	MSL-SS 41-R	MSL-SS 41-L	MS-HC 38-R	RE 88 PP 40-L	RE 88 SS 41-L	MP-PP 50-R	MP-SS 41-R	B70V-SR 25.1 PTFE	B70V-SR 25.1 PTFE
MS	SL	SL	MS	MS	SL	MS	MS	MS	MS	MS	MS	Packed Gland	MS
212 °F	212 °F	212 °F	212 °F	212 °F	212 °F	212 °F	248 °F	122 °F	212 °F	122 °F	212 °F	284 °F	284 °F
Impeller	Rotor	Impeller	Rotor	Impeller	Rotor	Impeller	Rotor	Impeller	Impeller	Rotor	Rotor	****	****
No	No	No	Yes	Yes	Yes	Yes	Yes	Yes	Yes	Yes	Yes	No	Yes
28.5	54	28.5	54	28.5	54	28.5	34	17.5	20	35	49	▲	▲
66	40	66	40	66	40	66	39.5	43	56	23	36	▲	▲
1000	900	1000	900	1000	900	1000	600	1300	1000	1000	600	25,000	25,000
2.0	1.5	2.0	1.5	2.0	1.5	2.0	1.8	2.1	2.0	1.8	1.5	*	*
14.3	14.3	14.3	15.0	15.0	15.0	15.0	15.9	12.5	16.8	12.2	16.2	26.0	26.0
29.5	54.5	29	54.5	29	54.5	29	35	16	20	37	51	▲	▲
68.5	36	68.5	36	68.5	36	68.5	36	42.5	62	26	29.5	▲	▲
300	100	300	100	300	100	300	100	1200	500	500	100	20,000	20,000
1.4	1.1	1.4	1.1	1.4	1.1	1.4	1.6	1.9	1.4	1.6	1.1	*	*
11.8	11.8	11.8	12.5	12.5	12.5	12.5	13.4	10.0	14.3	9.7	13.7	23.5	23.5
25	48	25	48	25	48	25	29	15	16	31	45	▲	▲
52.5	31	52.5	31	52.5	31	52.5	29.5	36	46	18	28	▲	▲
200	100	200	100	200	100	200	100	1000	400	300	100	20,000	20,000
1.6	1.2	1.6	1.2	1.6	1.2	1.6	1.5	1.7	1.6	1.5	1.2	*	*
17.3	17.3	17.3	18.0	18.0	18.0	18.0	18.9	15.5	19.8	15.2	19.2	29.0	29.0
26	53	26	53	26	53	26	30	16	18	35	52	▲	▲
42.5	33	42.5	33	42.5	33	42.5	26	36	43	26	33	▲	▲
500	400	500	400	500	400	500	400	1000	700	600	400	50,000	50,000
1.6	1.2	1.6	1.2	1.6	1.2	1.6	1.5	1.7	1.5	1.5	1.2	*	*
8.8	8.8	8.8	9.5	9.5	9.5	9.5	10.4	7.0	11.3	6.7	10.7	20.5	20.5
22.5	41.5	22.5	41.5	22.5	41.5	22.5	22	12	12	21	36	-	-
43	24.5	43	24.5	43	24.5	43	21.5	26	31.5	13	20.5	-	-
500	400	500	400	500	400	500	400	1000	700	600	400	-	-
1.6	1.2	1.6	1.2	1.6	1.2	1.6	1.5	1.7	1.5	1.5	1.2	-	-
7.8	7.8	7.8	8.5	8.5	8.5	8.5	9.4	6.0	10.3	5.7	9.7	-	-
27	48.5	27	48.5	27	48.5	27	26.5	×	18.5	×	47	▲	▲
54	33	54	33	54	33	54	33	×	49	×	38	▲	▲
600	300	600	300	600	300	600	250	×	1000	×	300	20,000	20,000
1.7	1.3	1.7	1.3	1.7	1.3	1.7	1.7	×	1.7	×	1.3	*	*
20.0	20.0	20.0	20.7	20.7	20.7	20.7	21.6	18.2	22.5	17.9	21.9	31.7	31.7
22	39.5	22	39.5	22	39.5	22	20	12.5	14	25	37	-	-
33	19.5	33	19.5	33	19.5	33	15	16.5	23	13	16.5	-	-
200	100	200	100	200	100	200	100	800	200	200	100	-	-
1.2	1.2	1.2	1.2	1.2	1.2	1.2	1.5	1.6	1.2	1.5	1.2	-	-
15.2	15.2	15.2	15.9	15.9	15.9	15.9	16.8	13.4	17.7	13.1	17.1	-	-

**** SS Rotor with PTFE Stator

▲ Supply application form to Lutz

× Not a suggested combination

Lutz Polypropylene Pump Tube

For a wide range of acids and alkalis



Sealless (MSL) or with Mechanical Seal (MMS)

Applications

The robust Lutz pump tube with mechanical seal or sealless is suitable for pumping clean and dirty, thin-bodied and slightly viscous, aggressive and non-aggressive liquids out of drums and small or large containers. The pump tube is non-lubricated, thus preventing contamination of the liquids pumped.

Structure and function (MMS-PP)

Lutz pump tubes are immersible centrifugal pumps. The drive shaft of this pump tube is sealed by a single-acting mechanical seal (MS). The patented mechanical seal is integral with the lower bearing housing. This position guarantees the best operating conditions and ensures the long service life of the mechanical seal. The pump must not be allowed to run dry.

Structure and function (MSL-PP)

Lutz pump tubes are immersible centrifugal pumps. The drive shaft of this pump tube is not sealed. The bearing housing unit behind the impeller is designed to prevent pumped liquid from rising between the shaft and the inner tube. This device guides the liquid which penetrates between the drive shaft and the shaft bearing back into the container being drained.



Warning:

The drum and container pump **must not** be used for flammable liquids.

Picture shows:

Pump tube with motor B 36 / MI 4

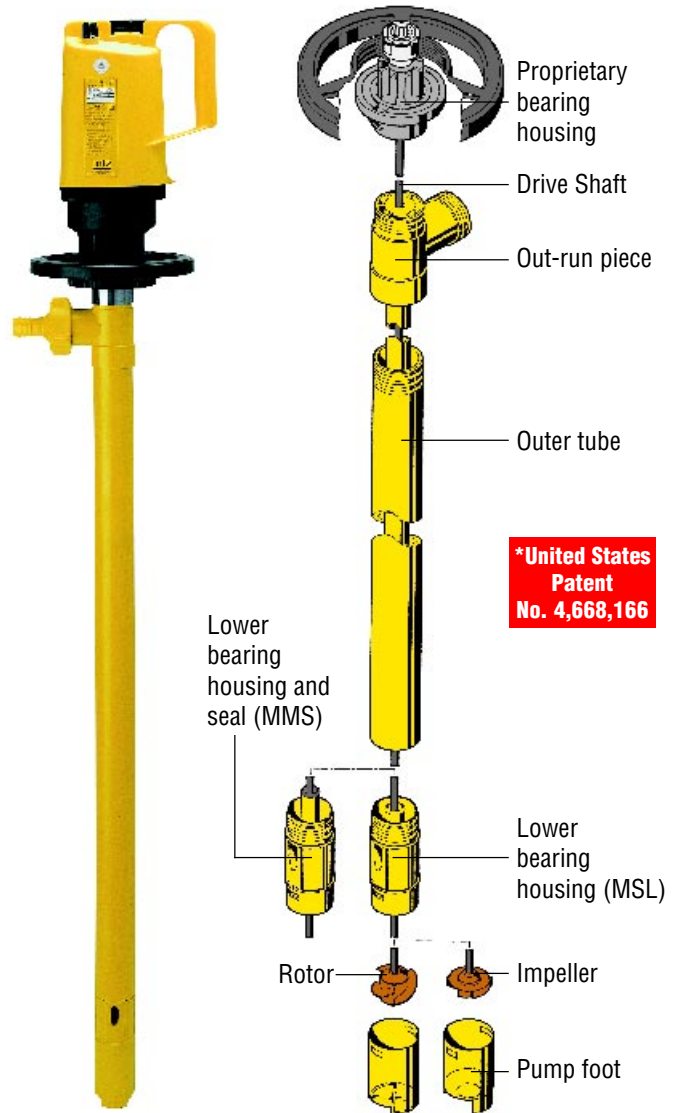

Type	MMS-PP (Mechanical Seal)	MSL-PP (Sealless)
Wetted parts		
Housing:	Polypropylene	Polypropylene
Mechanical seal:	Carbon, SiC, Viton, HC-4 (2.4610)	None
Bearings:	PTFE	PTFE
Drive shaft:	HC-4 (2.4610) optional Stainless Steel (316)	HC-4 (2.4610) optional Stainless Steel (316)
Examples of liquids:	Acids, Alkalis, Vegetable Oils, Liquids, Phosphates, Sulphates, Nitrates, Chlorates, Paints and Inks, Water, Sulphites	Acids, Alkalis, Galvanic Fluids, Phosphates, Sulphates, Nitrates, Chlorates, Paints and Inks, Water, Oils, Sulphites
Type of impeller:	axial-flow (rotor) or radial-flow (L) Material: PP	axial-flow (rotor) or radial-flow (L) Material: PP

Immersion depths:

27", 39", 47", 63"
Special immersion depths on request.

Note:

Axial-flow rotor for high delivery rate and low delivery head. Radial-flow impeller for low delivery rate and high delivery head.

For more details request literature PP-SL (Ref. no. 9000-136)

Lutz PVDF Pump Tube

For concentrated liquids



Sealless (MSL) or with Mechanical Seal (MMS)

Applications

The robust Lutz pump tube with mechanical seal or sealless is suitable for pumping clean and dirty, thin-bodied and slightly viscous, aggressive and non-aggressive liquids out of drums and small or large containers. The pump tube is non-lubricated, thus preventing contamination of the liquids pumped.

Structure and function (MMS-PVDF)

Lutz pump tubes are immersible centrifugal pumps. The drive shaft of this pump tube is sealed by a single-acting mechanical seal (MS). The patented mechanical seal is integral with the lower bearing housing. This position guarantees the best operating conditions and ensures the long service life of the mechanical seal. The pump must not be allowed to run dry.

Structure and function (MSL-PVDF)

Lutz pump tubes are immersible centrifugal pumps. The drive shaft of this pump tube is not sealed. The bearing housing unit behind the impeller is designed to prevent pumped liquid from rising between the shaft and the inner tube. This device guides the liquid which penetrates between the drive shaft and the shaft bearing back into the container being drained.



Warning:

The drum and container pump **must not** be used for flammable liquids.

Picture shows:

Pump tube with motor B 55 T / MA II 5.

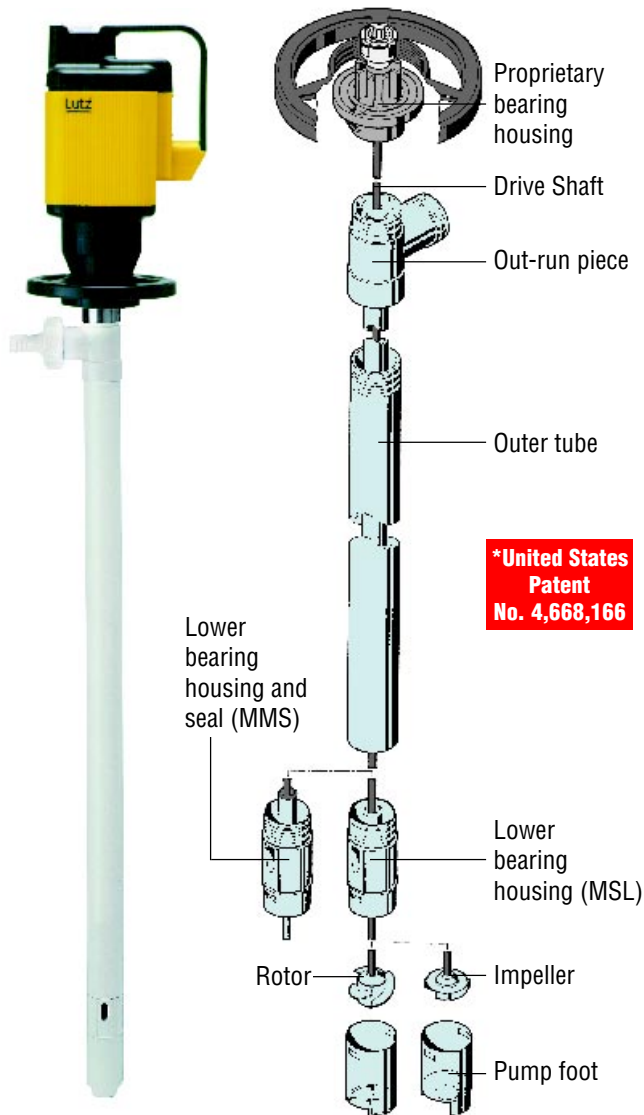

Type	MMS-PVDF (Mechanical Seal)	MSL-PVDF (Sealless)
Wetted parts		
Housing:	PVDF	PVDF
Mechanical seal:	Carbon, SiC, Viton, HC-4 (2.4610)	None
Bearings:	PTFE	PTFE
Drive shaft:	HC-4 (2.4610)	HC-4 (2.4610)
Examples of liquids:	Highly concentrated Acids and Alkalis, Ethyl Chloride, Chloroform, Chromic Acid, Phosphoric Acid 95%, Perchloric Acid, Sulphuric Acid, Chlorine Water etc.	Highly concentrated Acids and Alkalis, Bromic Acid, Hydrobromic Acid, Chloroform, Dimethyl Phthalate, Hydrofluoric Acid, Potassium Bromate, Sodium Perchlorate, Phosphoric Acid 95%, Nitric Acid etc.
Type of impeller:	axial-flow (rotor) or radial-flow (L) Material: ETFE	axial-flow (rotor) or radial-flow (L) Material: ETFE

Immersion depths:

27", 39", 47"
Special immersion depths on request.

Note:

Axial-flow rotor for high delivery rate and low delivery head. Radial-flow impeller for low delivery rate and high delivery head.

Lutz Aluminum Pump Tube

For neutral liquids



Sealless (MSL) or with Mechanical Seal (MMS)

Applications

The robust Lutz pump tube with mechanical seal or sealless is so designed that it can run dry; it is suitable for pumping non-aggressive, clean, thin-bodied and slightly viscous liquids out of drums and small or large containers.

The pump tube is non-lubricated, thus preventing contamination of the liquids pumped.

Structure and function (MMS-Alu)

Lutz pump tubes are immersible centrifugal pumps.

The drive shaft of this pump tube is sealed by a single-acting mechanical seal (MS) and two shaft seals located behind it, making a robust sealing system.

The pump tube must not be allowed to run dry.

Structure and function (MSL-Alu)

Lutz pump tubes are immersible centrifugal pumps.

The drive shaft of this pump tube is not sealed. The bearing housing unit behind the impeller is designed to prevent pumped liquid from rising between the shaft and the inner tube. This device guides the liquid which penetrates between the drive shaft and the shaft bearing back into the container being drained.



Warning:

The drum and container pump **must not** be used for flammable liquids.

Picture shows:

Pump tube with motor B 55 T / MA II 5.

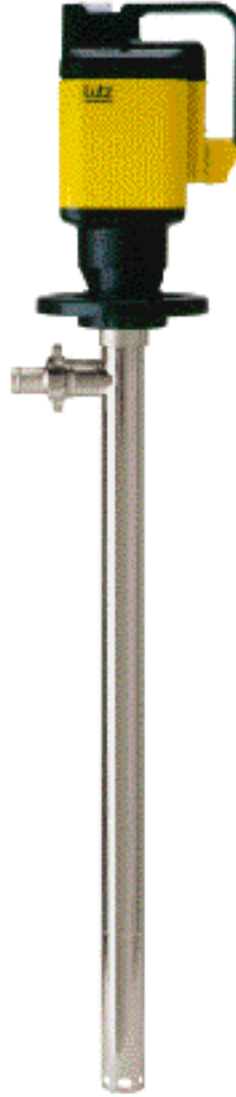

Type	MMS-Alu (Mechanical Seal)	MSL-Alu (Sealless)
Wetted parts		
Housing:	Alu, Stainless Steel (316)	Alu, Stainless Steel (316)
Seals:	Viton	None
Mechanical seal:	Carbon, Ceramic, Viton, Stainless Steel	None
Bearings:	Carbon	Carbon
Drive shaft:	Stainless Steel (316)	Stainless Steel (316)
Examples of liquids:	Thin-bodied and slightly viscous Mineral Oils, contaminated Oils, Cooling Lubricants, Vegetable Oils, Butylene Glycol, Diesel Fuel, Chlorodiphenyl, Fuel Oil, Ethereal Oils etc.	Thin-bodied and medium viscous Mineral Oils, Butylene Glycol, Diesel Fuel, Fuel Oil, Crude Oil, Phenol, Glycerine, Fatty Acid, Ethereal Oils, Linseed Oil, Paraffin Oil etc.
Type of impeller:	axial-flow (rotor) or radial-flow (L) Material: ETFE	axial-flow (rotor) or radial-flow (L) Material: ETFE

Immersion depths:

27", 39", 47"
Special immersion depths on request.

Note:

Axial-flow rotor for high delivery rate and low delivery head. Radial-flow impeller for low delivery rate and high delivery head.

Lutz Stainless Steel Pump Tube

For flammable and aggressive liquids



Sealless (MSL) or with Mechanical Seal (MMS)

Applications

The robust Lutz pump tube with mechanical seal or sealless is suitable for pumping clean and dirty, thin-bodied and slightly viscous, aggressive and non-aggressive, flammable and non-flammable liquids out of drums and small or large containers. The pump tube is non-lubricated, thus preventing contamination of the liquids pumped.

Structure and function (MMS-SS)

Lutz pump tubes are immersible centrifugal pumps. The drive shaft of this pump tube is sealed by a single-acting mechanical seal (MS) and two shaft seals located behind it, making a robust sealing system. The pump tube must not be allowed to run dry.

Structure and function (MSL-SS)

Lutz pump tubes are immersible centrifugal pumps. The drive shaft of this pump is not sealed. The bearing housing insert behind the impeller is designed to prevent the pumped liquid from rising between the shaft and the inner tube. This insert guides the liquid which penetrated between the drive shaft and the shaft bearing back into the container being drained.



The pump tube is "Zone 0" approved in combination with the original Lutz motors Silver Star / MD-1 / MD-2 in accordance with standards for use in hazardous locations.

Picture shows:
Pump tube with motor Silver Star ME I 6.



Type	MMS-SS (Mechanical Seal)	MSL-SS (Sealless)
Wetted parts		
Housing:	Stainless Steel (316)	Stainless Steel (316)
Seals:	Viton	None
Mechanical seal:	Carbon, Ceramic, Viton, Stainless Steel (316)	None
Bearings:	Carbon	Carbon
Drive shaft:	Stainless Steel (316)	Stainless Steel (316)
Examples of liquids:	Gasoline, thin-bodied Oils, Solvents, Chlorine Carbon Hydrogens, Alcohols, Amines, Benzoles, Phenoles, Toluol, Xylol, Fruit Juices, Paints and Inks, Vegetable Oils etc.	Alcohols, Aceton, Acetonitrile, Acetates, Ether, Diethanolamine, Freon, Frigen, Methylene Chloride, Dimethyl Phthalate, Dioxane, Diethylamine, Pyridine etc.
Type of impeller:	axial-flow (rotor) or radial-flow (L) Material: ETFE	axial-flow (rotor) or radial-flow (L) Material: ETFE

Immersion depths:

27", 39", 47", 63"
Special immersion depths on request.

Note:

Axial-flow rotor for high delivery rate and low delivery head. Radial-flow impeller for low delivery rate and high delivery head.

For correct bonding and grounding see page 18.

Lutz Hastelloy C Pump Tube

For extremely corrosive applications



MS-HC Mechanical Seal

Applications

The robust Lutz pump tube with mechanical seal is suitable for pumping nearly all kinds of liquids, whether extremely aggressive or flammable, clean or dirty, thin-bodied or slightly viscous out of drums and small or large containers

Structure and function

Lutz pump tubes are immersible centrifugal pumps.

The drive shaft of this pump tube is sealed by a single-acting mechanical seal, a shaft seal located behind and a sealing liquid, making a robust sealing system.

The pump tube must not be allowed to run dry.

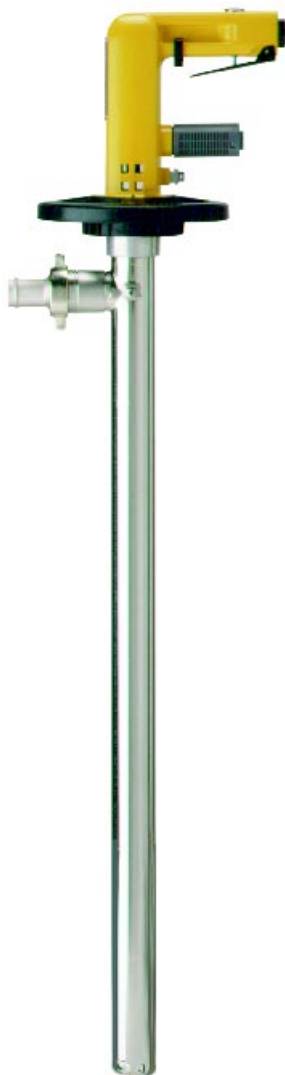

Picture shows:

Pump tube with air motor MD-2.



The pump tube is "Zone 0" approved in combination with the original Lutz motors Silver Star / MD-1 / MD-2 in accordance with standards for use in hazardous locations.

Type	MS-HC (Mechanical Seal)
Wetted parts	
Housing:	HC-4 (2.4610)
Seals:	Viton
Mechanical seal:	Ceramic, Viton, HC-4 (2.4610)
Bearings:	Carbon
Drive shaft:	HC-4 (2.4610)
Examples of liquids:	Bromine, Chlorosulphonic Acid, Butylchloride, Chlorine Water and nearly all kinds of liquids
Type of impeller:	axial-flow (rotor) Material: ETFE

Immersion depths:

27", 34", 47"
Special immersion depths on request.

For correct bonding and grounding see page 18.

Lutz Pump Tube RE 88 in PP and Stainless Steel

For complete drainage of highly toxic, expensive and sensitive liquids



RE 88 PP / RE 88 SS Mechanical Seal

Applications

The pump tube RE-88 PP and RE-88 SS is designed to be used where drums or other containers have to be completely drained. The relatively small pump tube diameter of 41 mm also makes the unit ideal for use in narrow-necked containers or in drums with a 2" bunghole. The pump tube is non-lubricated, thus preventing contamination of the liquids pumped.

Structure and function

Lutz pump tubes are immersible centrifugal pumps. The drive shaft of this pump is sealed by a single-acting mechanical seal (MS) and two shaft seals located behind it, making a robust sealing system. The pump tube must not be allowed to run dry.

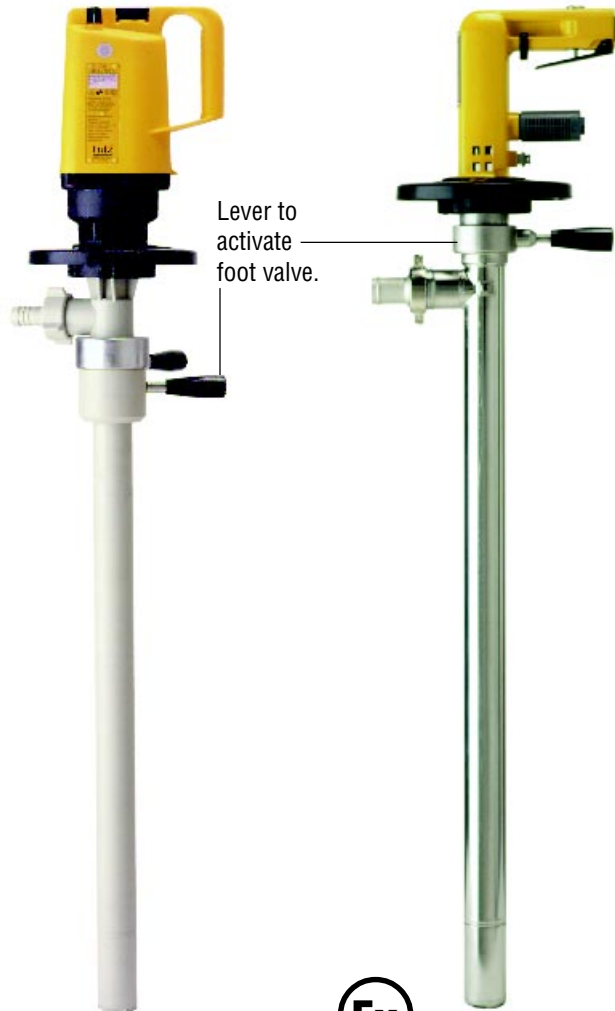

Warning:

The RE 88 Polypropylene pump **must not** be used for flammable liquids.



The pump tube is "Zone 0" approved in combination with the original Lutz motors Silver Star / MD-1 / MD-2 in accordance with standards for use in hazardous locations.

Function

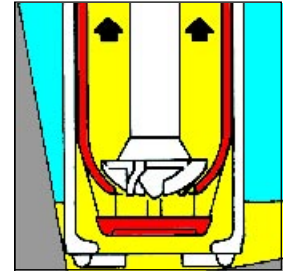

Sealing pot is open - the liquid is pumped off.

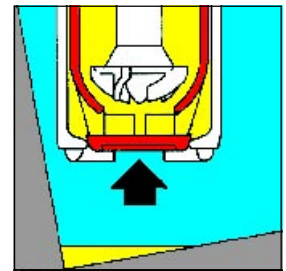

Closed sealing pot prevents runback when the pump is extracted.

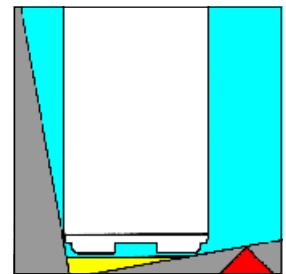

Almost 100 % drainage when the drum is tilted.

Type	RE-88 PP (Mechanical Seal)	RE-88 SS (Mechanical Seal)
Wetted parts		
Housing:	PP	Stainless Steel (316)
Seals:	Viton	FEP coated
Mechanical seal:	Carbon, Ceramic, Viton, HC-4 (2.4610)	Carbon, Ceramic, Viton, HC-4 (2.4610)
Bearings:	Carbon	Carbon
Drive shaft:	Stainless Steel (316)	Stainless Steel (316)
Examples of liquids:	Water, Acids, Alkalis, Hydrazine, Oils, Fruit Juices, Galvanic Fluids, Phosphates, Sulphates, Nitrates etc.	Petrol, Fuel Oil, Diesel Oil, thin-bodied Oils, Solvents, Chlorine Carbon Hydrogens, Alcohols, Amines, Benzoles, Phenoles etc.
Type of impeller:	radial-flow (L) Material: PP	radial-flow (L) Material: ETFE

Immersion depths:

27", 39", 47"
Special immersion depths on request.

For correct bonding and grounding see page 18.

Lutz MP Pump Tube in PP and Stainless Steel

For mixing and pumping of emulsions and suspensions



MP-PP / MP-SS Mechanical Seal

Applications

The Lutz mixing pump tube is designed to be used in any situation where it is necessary to mix and pump in a single operation. The relatively small pump tube diameter of 50 mm (Polypropylene) and 41 mm (Stainless Steel) also makes the unit ideal for use in narrow-necked containers or in drums with a 2" bunghole. The rate of flow, viscosity and density of the medium determine the mixing intensity and the delivery rate of the mixing pump tube. Experience has shown that the mixture quantity should preferably not exceed 55 Gallons if the medium is thin-bodied. The drive shaft of this pump tube is sealed by a single-acting mechanical seal (MS) and two shaft seals located behind it, making a robust sealing system. The pump tube must not be allowed to run dry. The pump tube is non-lubricated, thus preventing contamination of the liquids pumped.



Warning:

The mixing pump tube **must not** be used for flammable liquids.



The pump tube is "Zone 0" approved in combination with the original Lutz motors Silver Star / MD-1 / MD-2 in accordance with standards for use in hazardous locations.

Function

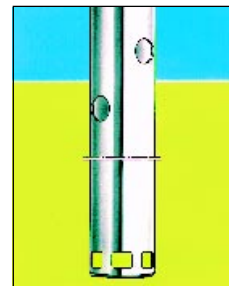

Immerse

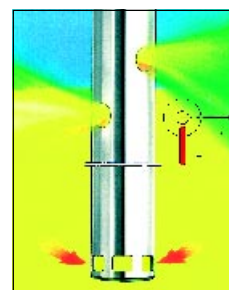

Mix

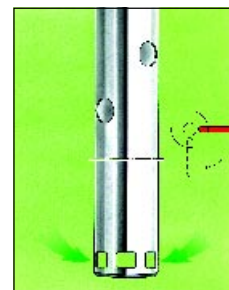

Pump

For correct bonding and grounding see page 18.

Type	MP-PP (Mechanical Seal)	MP-SS (Mechanical Seal)
Wetted parts		
Housing:	PP	Stainless Steel (316)
Seals:	–	FEP coated
Mechanical seal:	Ceramic, Viton, Stainless Steel, HC	Ceramic, Viton, Stainless Steel
Bearings:	Carbon	Carbon
Drive shaft:	Stainless Steel (316)	Stainless Steel (316)
Examples of liquids:	Chemical, pharmaceutical and metalworking industries, in food production, in printing works, in car repair workshops and in painting/decorating firms.	
Type of impeller:	axial-flow (rotor) Material: PP	axial-flow (rotor) Material: ETFE

Structure and function

Lutz pump tubes are similar to immersible centrifugal pumps. The drive shaft of this pump is sealed by a single-acting mechanical seal (MS) and two shaft seals located behind it, making a robust sealing system. The pump tube must not be allowed to run dry.

Immersion depths:

39", 47"
Special immersion depths on request.

For more details request literature MP (Ref. no. 9000-144)

Lutz Progressive Cavity Pump B 70V-SR

Smooth pumping of highly viscous liquids



B70V-SR

(Portable, 32 lbs with motor)

Operating Data

Quantity: up to 13 GPM
 Delivery head: up to 200 FT (87 PSI)
 Temperature of medium: up to 284 °F
 Viscosity: up to 40,000 cps

Features:

- Viscous fluids (will handle from 1 cps to 100,000 cps D or DA models)
- Abrasive fluids
- High solid content slurries
- Shear sensitive fluids
- Metering applications (1% repeatability)
- High pressure applications (up to 401 ft head – 174 psi)
- Particulates to 1/8"
- Fluids with entrained air (will not vapor lock)
- Corrosives (SS pump tube + wide variety of elastomers available)
- Non-lubricating fluids
- Temperatures to 284 °F
- Low NPSH applications
- Positive displacement applications
- Pulsation-free delivery
- Quiet operating
- User friendly – easy to dismantle & clean

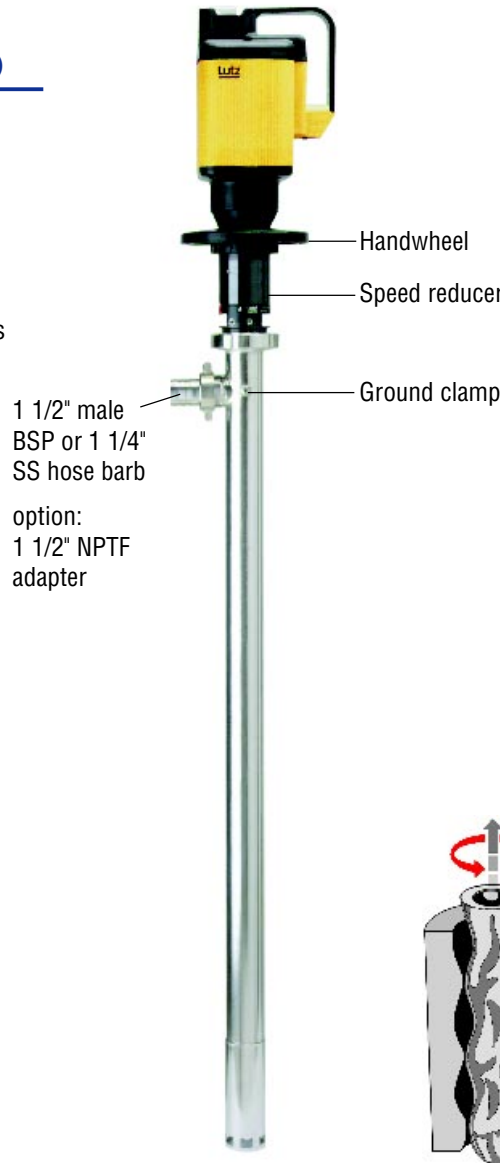

option:
 1 1/2" NPTF adapter

Pump Tubes

Pump tubes with different flow rates and immersion depths are available for the Lutz B70V-SR. The speed reducer is mounted directly on the pump tube. This reduces the relatively high speeds of the universal or compressed-air motors to a suitable speed for the pump tube of around 690 rpm. The pump tube, drive shaft and eccentric screw are made of Stainless Steel (316). Do not run dry or against closed valve.

Immersion tube diameter:
 54 mm (2.12")

Connection thread: 1 1/2"

Hose connection: 1 1/4"

Immersion depth:
 1000 mm (39.4") or
 1100 mm (43.3")

Stators optionally in

NBR light, Viton or PTFE. The stator insert is either vulcanized or clamped into a separate Stainless Steel sleeve at the end of the pump. The drive shaft is fixed and mounted in the speed reducer. The shaft is sealed by a single-acting mechanical seal or by a soft packing gland. For applications in the food, pharmaceutical and cosmetics industry, no special shaft joint protection is needed.

Accessories

Bypass valves, hoses, hose clips, dosing devices, electronic flow meters, batch dosing appliance with time control and other accessories are available on request.

Drive Motors

A variety of electric and compressed air motors are available. (see page 5)

For more details request literature B70-V

Type	B70V-SR
Wetted parts	
Housing and Rotor:	Stainless Steel (316)
Seals:	Viton (FPM)
Mechanical seal:	Carbon/SS, Viton or SiC/SiC , Viton
Packing gland:	PTFE soft packing, safe for use with foodstuffs
Drive shaft:	Stainless Steel (316)
Stator materials:	NBR light, Viton, PTFE
Examples of liquids:	<p>Chemical industry: acids, lyes, sludge, viscous pastes, dispersions, adhesives, etc.</p> <p>Cosmetics industry: creams, soaps, toothpaste, shampoos and raw materials for soaps</p> <p>Confectionery industry: honey, syrups and preserves</p> <p>Paint and lacquer factories: paints, lacquers and pastes</p> <p>Food industry: milk, whey, cheese, spread, quark and ketchup</p> <p>Mineral oil industry: high-viscosity oils and fluid greases.</p>

Lutz B2 multipurpose Drum and Laboratory Pump

115 V or rechargeable, cordless



Universal Application

The Lutz B2 is an indispensable aid wherever liquids with a viscosity similar to that of water have to be filled, transferred, mixed or metered in small quantities, to or from drums, glass carboys, canisters and other vessels. Even narrow-necked containers such as bottles or pistons present no problem. The rate of flow can be reduced or cut off as required. The "small but strong" B2 has proven highly successful in laboratories, chemical companies and chemists' shops. Versatile and inexpensive: The ideal starter model.

the lower end of the pump tube, and is therefore always immersed by the liquid. Suction problems are unknown when working with Lutz pump tubes. Pump tube materials which come into contact with the delivery medium: Polypropylene (PP) or Stainless Steel (316), Carbon, ETFE and Hastelloy C.

Drive Motor

Double insulated, splash proof and radio-suppressed universal motor. This 115 V motor is equipped with a 9.8-foot power cord, molded plug, on-off switch and integrated motor protection switch. Protection class IP 44.

Features:

- Light weight
- Fully portable (B2 A - Cordless)
- Sealless stainless steel or polypropylene pump tubes
- Different tube lengths and diameters for your individual needs
- Up to 19 G.P.M
- Radio suppressed
- Double insulated splash proof motor (B2)
- Integrated splash proof on-off switch
- Integrated motor protection switch
- Special air flow cooling system
- Complete user-friendly accessories
- Intermittent/light duty
- Not suitable for hazardous location
- 16' cord + plug-2 wire
- 230 watt/0.31 HP motor
- 120 V, 60 hz
- 10,000 rpm
- Replacable brushes
- Pressures to 22 feet of head

Aggressive Media - No Problem

The Lutz B2 offers a safe and reliable means of handling even the most aggressive media. For example: organic and inorganic acids and bases.

The Lutz B2 pump series

The Lutz B2 pump series is made up of four models, all of which are ideally suited to the universal requirements of laboratory application. Each is supplied as a complete appliance consisting of a drive motor with fixed pump tube in Polypropylene (PP) or Stainless Steel (316).

Pump Tube

The pump tube used in the Lutz B2 is sealless and is permanently fixed to the drive motor. It transmits its power with the aid of an elastic coupling to the drive shaft which is mounted in the inner tube. The rotor is arranged at

B2-A (battery operated)

4.8 Volt motor, rechargeable charger supplied. 10,000 rpm, on/off switch, intermittent duty will pump up to 100 Gallons, 3 gpm, pressures to 11 feet of head, temperatures to 140 °F, 3/4" hose connection.



For more details request literature B2/B2-A (Ref. no. 9000-117)

Lutz Modular Flow Control System

Totalizing and batch control at your fingertip

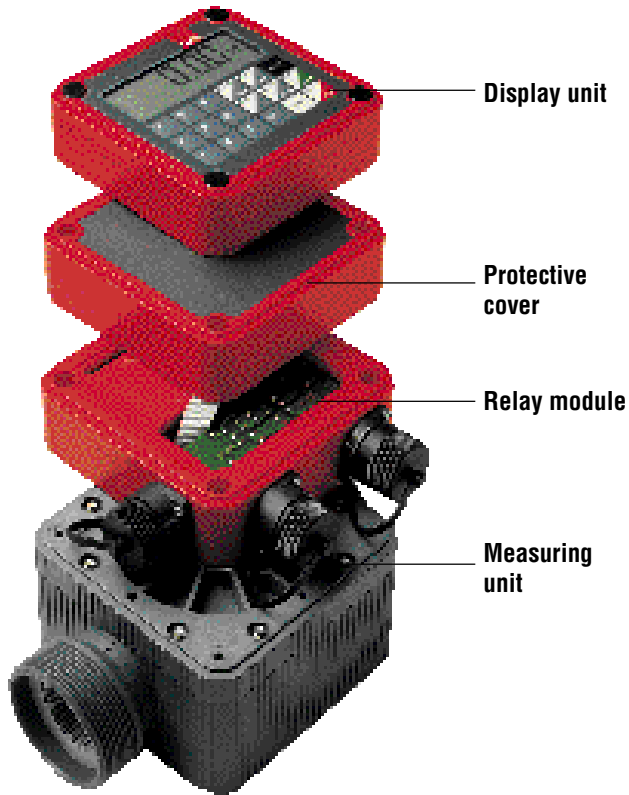

Benefits:

- Modular Construction
- Robust Design
- Choice of Resistant Materials (consult our chemical resistant table)
- Fingertip Calibration
- Remote Control Facility
- Large 6-Digit LCD Display
- Built-in Data Protection
- Memory Capacity for 9 different liquids
- Protective Strainer provided
- Battery Condition Indicator
- No special Batteries required
- Easy Installation
- Trouble-free Maintenance
- Modular Design
- Batch Control

To meet the growing challenges of our customers and their environments, Lutz has developed an efficient cost-effective flow meter, using existing measuring technology and state of the art electronics.

The flow meter can be combined with selected accessories to form a complete flow control system.

Features:

- 2.6 GPM - 26 GPM
- 5 Materials of construction
- 3 Models for Ex
- Electric or battery operated
- 4 Units of measure: GPM, LPM, Kilogram, Imperial GPM
- Dosing capability
- Locking function in automatic mode
- 87 psi max.
- 186° F max.
- 2,000 cps max.
- 1% accuracy
- Will operate with PLC
- Totalize
- Cycle count

For more details request literature: Lutz Flow Control System (Ref. no. 9000-123)



Genuine Lutz Accessories for your safety and convenience, single source "one stop shopping"

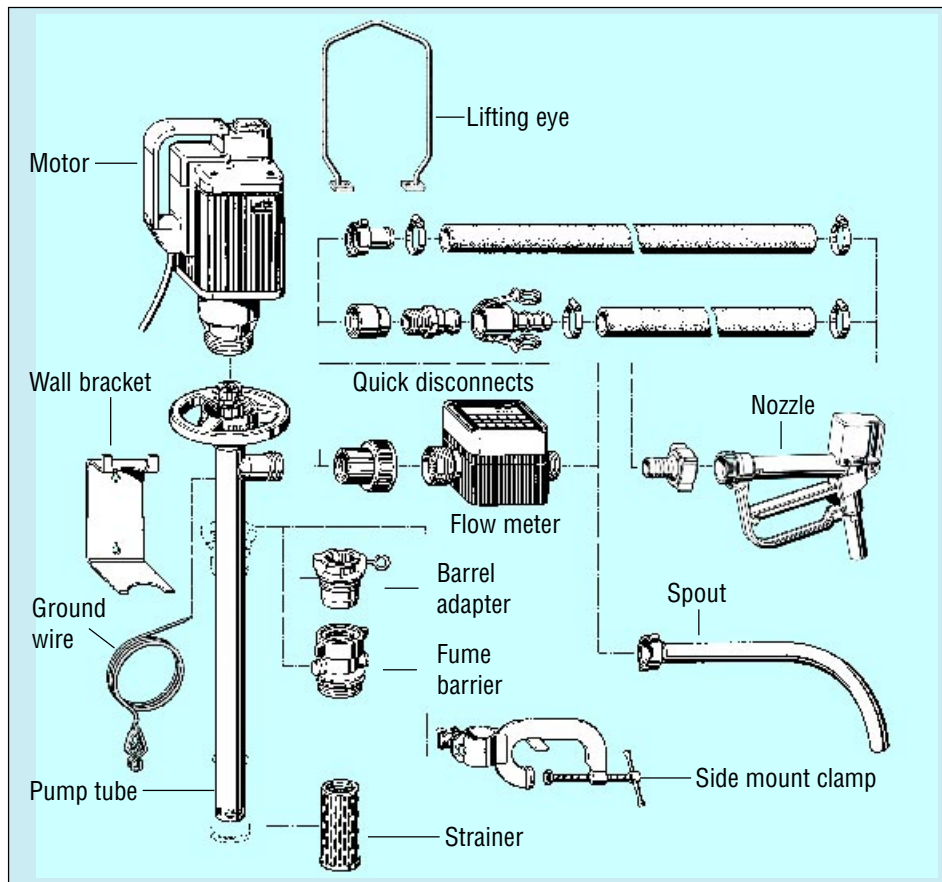

The picture gives you an illustration of the entire Lutz accessories for drum pumps.

You can choose the component parts which suit you best.

For more details request literature: Lutz Accessories

(Ref. no. 9000-142)

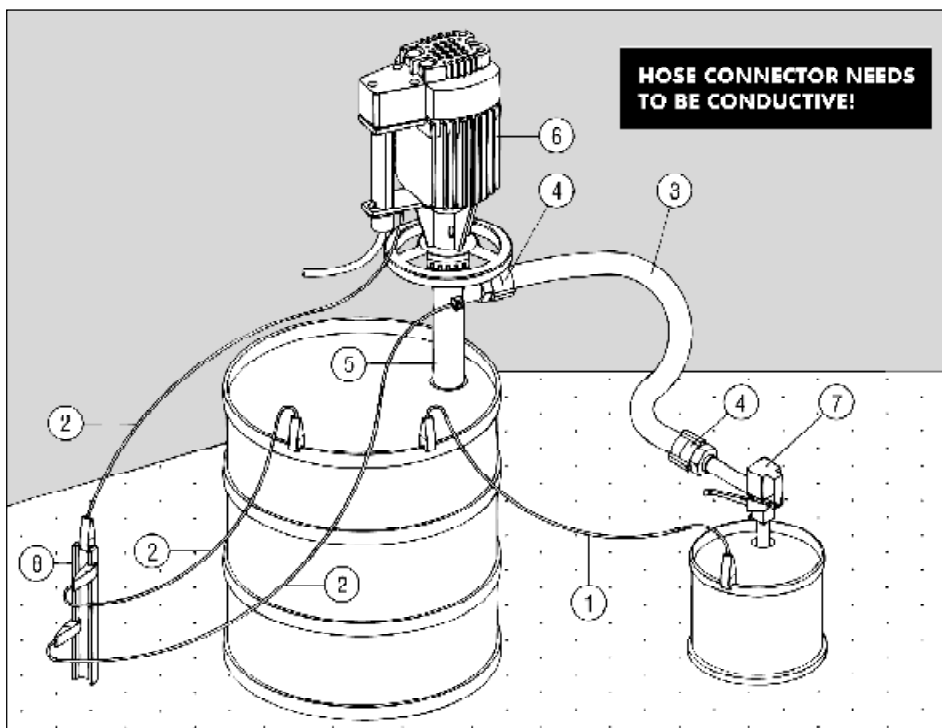

Required accessories when using explosion proof pumps in hazardous locations.

Explosion proof plug and socket outlets, bonding and grounding cable, conductive hoses and nozzles in Stainless Steel.

Ex-Motor (ME I, MD-1, MD-2)

Bonding and Grounding Diagram

- ① Bonding wire
- ② Ground wire
- ③ Conductive hose, (10⁶ Ohm)
- ④ Conductive fitting of the hose into hose connector
- ⑤ Metal pump tube for zone „0“* in Stainless Steel or Hastelloy „C“
- ⑥ Explosion proof motor ME I / MD-1 / MD-2
- ⑦ Nozzle in Stainless Steel
- ⑧ Grounding rod

*Zone „0“: Defines a constant hazardous explosive atmosphere. Covers interior of drum/container used for storing or transporting of explosive liquids. Equipment approved for zone „0“ must be specially tested and certified.

Questionnaire for specific application information



Copy - fill in - fax back to (770) 923-0334 or e-mail to lutzpumps@mindspring.com or visit us at www.lutzpumps.com

We would like to furnish you with information about the pump best suited for your application. This requires a knowledge of the system in which the pump is to operate. If you will answer the following questions, we will be able to give you a specific recommendation.

Company _____

Address _____

City _____ State _____ Zip _____

Phone Number _____ Fax Number _____

Contact Name _____

Pump planning made easy!

1. Fluid to be pumped: _____

2. Capacity required: _____ U.S.G.P.M. Total head or psi _____ ft. _____ psi

3. Pumped fluid temperature: _____ ° F Specific gravity _____

4. Viscosity: _____ cps

5. Transferring from: _____ 55 Gallon drum _____ Carboy _____ Vat _____ Tote _____ IBC _____ Sump

Description: _____

6. Other pertinent data: _____

7. Preferred materials of construction:

Length of Pump Tube:

_____ Polypropylene

_____ 27 inches (carboys)

_____ 316 Stainless Steel

_____ 39 inches (55 gallon)

_____ PVDF

_____ 47 inches (vats/reactors)

_____ Hastelloy C

_____ 63 inches (PP & SS)

_____ Aluminum

_____ _____ inches Special Length

8. Motor characteristics required:

_____ volts _____ cycles _____ phase

9. Enclosure: _____ Open Drip Proof (Available with Speed Control)

_____ TEFC

_____ Explosion Proof-U.L. Listed, Class I Groups C & D. Class II, Group G Motor

_____ Air Operated Motor Ex

10. Other characteristics: _____

11. Accessories: _____

Overview of actual Lutz brochures

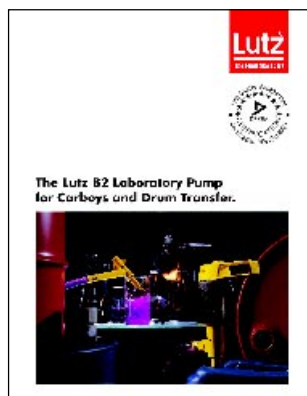

Brochure B2
Ref. no. 9000-117

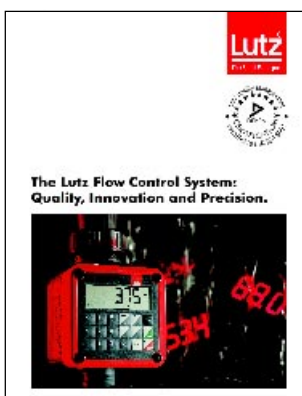

Brochure Flow Control System
Ref. no. 9000-123



Brochure Silverstar (ME I 6)
Ref. no. 9000-138

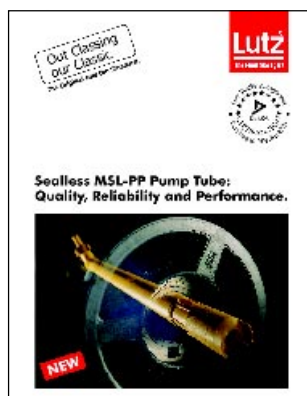

Brochure MSL-PP Pump Tube
Ref. no. 9000-136

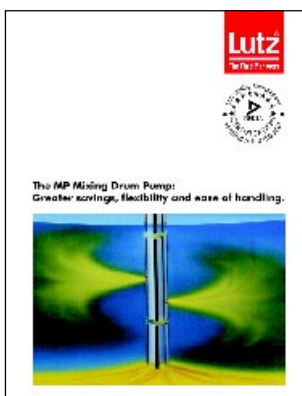

Brochure Mixing Pump Tube
Ref. no. 9000-144

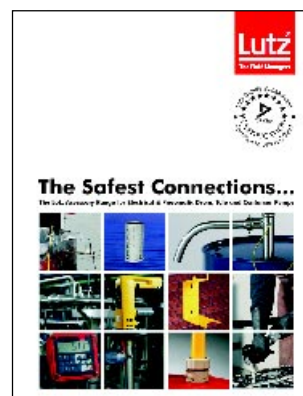

Brochure Accessories
Ref. no. 9000-142

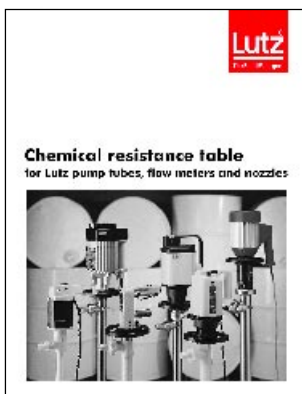

Chemical resistance table
Ref. no. 9000-109

Please call us and ask for brochure(s)



Lutz Pumps, Inc.
1160 Beaver Run Road
Norcross, GA 30093-4898
Phone: (770) 925-1222
(800) 843-3901
Fax: (770) 923-0334
<http://www.lutzpumps.com>
e-mail: lutzpumps@mindspring.com

