

PE-2.5F-PW SERIES

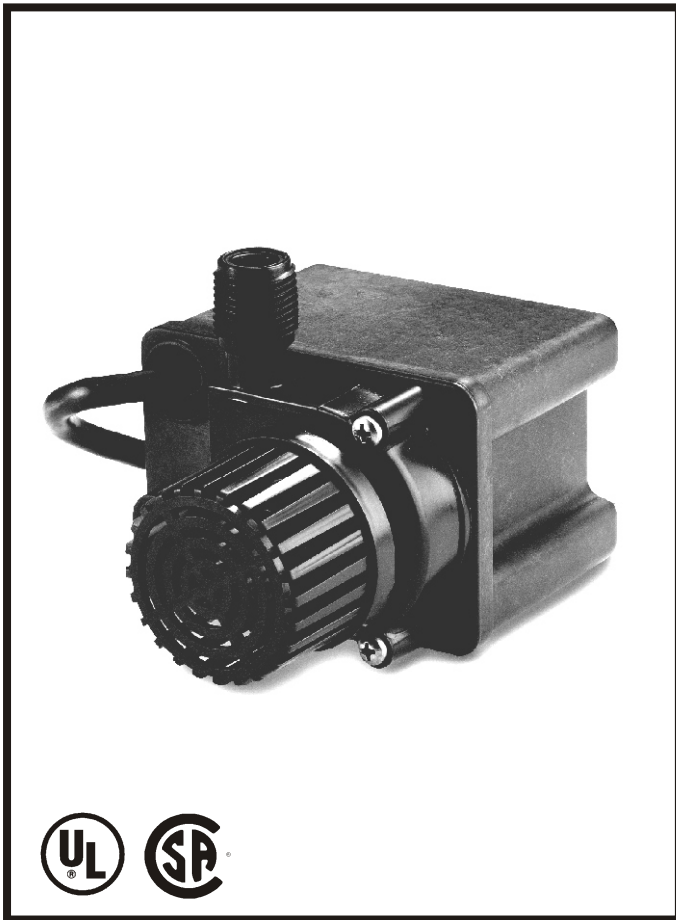

Features

- Environmentally safe, oil-less
- Energy efficient
- Corrosion resistant body
- 15' Cord
- 13.4' maximum lift
- 80 watts
- 1/2" MNPT Discharge
- Discharge accepts 3/4" I.D. tubing
- For submersible use only

Construction

- Motor — 1/28 HP Epoxy Encapsulated
- Intermittent Liquid Temp. up to — 120° F
- Intake — Screened
- Discharge — 1/2" MNPT
- Housing — Glass-filled polyester
- Cover — Glass-filled polyester
- Volute — Polypropylene
- Impeller — Nylon
- Shaft Seal — Viton®
- Screen — Polyethylene

Small submersible epoxy encapsulated pump for commercial, industrial and home use. Applications include statuary fountains, water displays, air conditioners, machine tool coolants and many other applications where liquid must be transferred or recirculated. This compact 475 GPH pump features a 1/2" MNPT discharge, 13.4' shut-off head capability, screened inlet and a 15' power cord.

PE-2.5F-PW SERIES

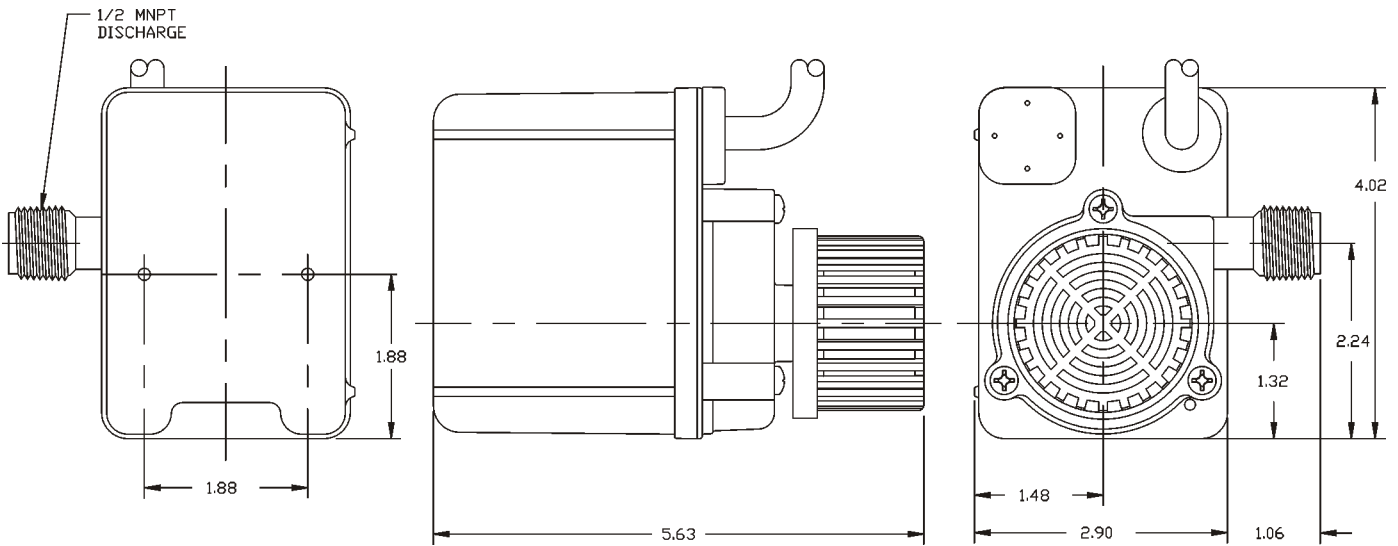

Specifications

Model No.	Item No.	Discharge	Listings	HP	Volts	Hertz	Amps	Watts	Performance (GPH @ Head)					Shut Off		Pwr. Cord (ft)	Weight (Lbs.)
									1'	3'	5'	8'	10'	Feet	PSI		
PE-2.5F-PW	566633	1/2" MNPT	UL/CSA	1/28	115	60	1.4	80	475	440	395	270	205	13.4	5.8	15	5.33

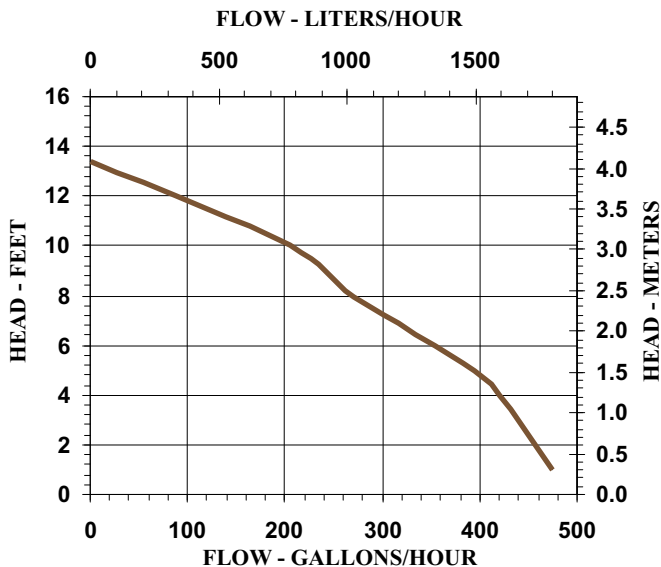

Replacement Parts

Volute	118357
Impeller	118444
Screen	118911
Seal Ring	928011