

10S SERIES

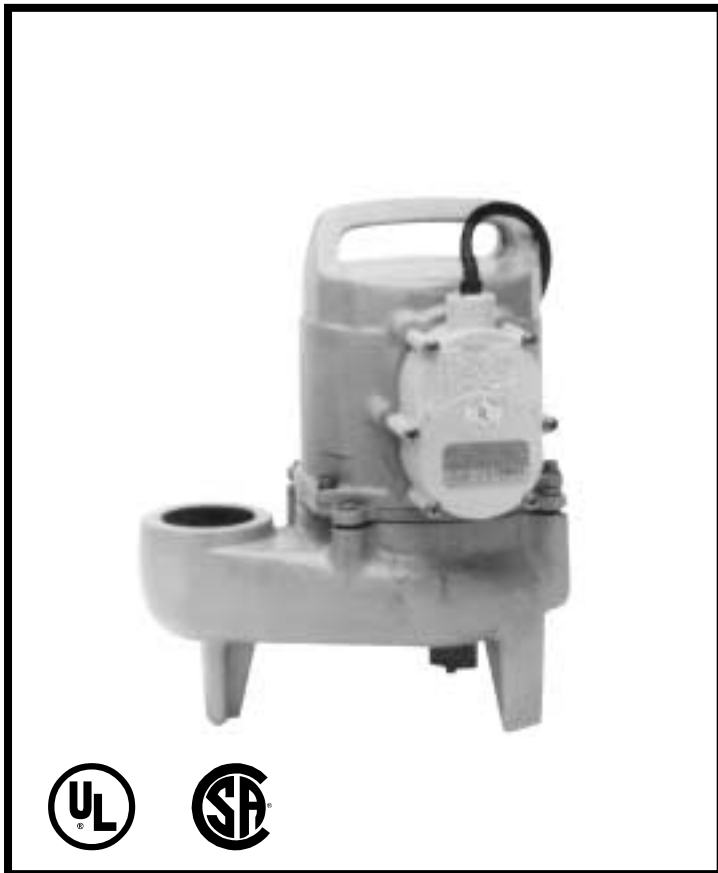

Features

- Handles liquids and solid waste materials up to 2" diameter.
- Cast iron pump housing and volute with protective epoxy coating for corrosion and rust resistance
- Oil-filled motor housing for lifetime lubrication and rapid heat dissipation
- Stainless steel fasteners
- Mechanical seals (stainless steel spring, nitrile parts, carbon and ceramic faces)
- Thermal overload protection
- Manual and Automatic models
- Automatic operation has 14 "On" level and 8 to 12 "Off" level range with piggyback mechanical float switch
- All models are UL/CSA listed.

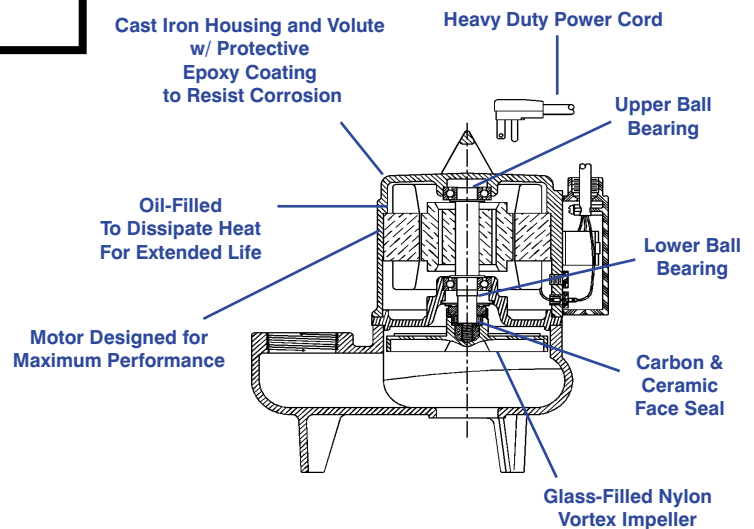

For increased pumping demands, the Model 10S Series Wastewater and Sewage Ejector pumps offer greater capacities than the 9S Series. Pumps feature a 2" discharge, with a lift of 20'. Cast iron housing and volute with protective epoxy coating.

Little Giant Pump Co.

10S SERIES SEWAGE EJECTOR PUMP

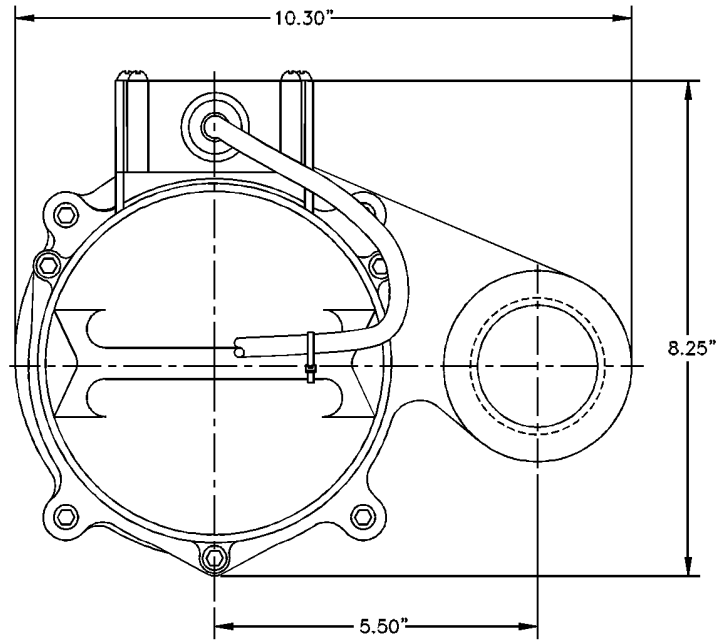
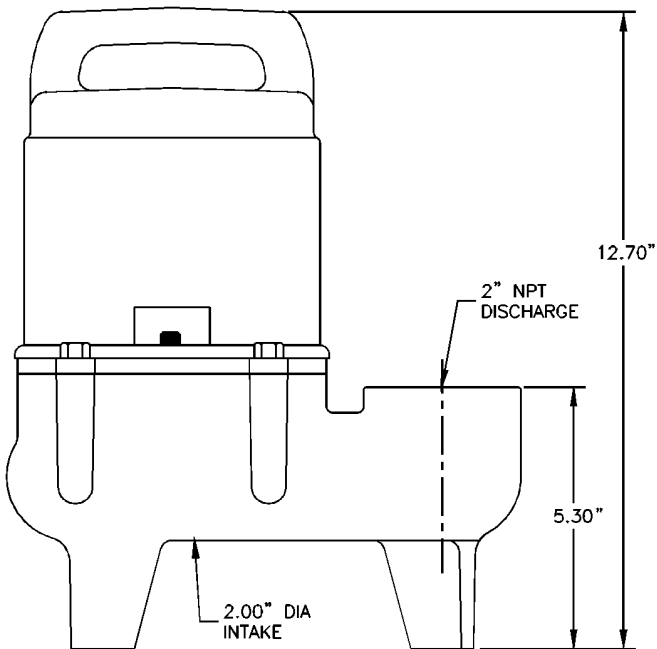

Specifications

MODEL NO.	ITEM NO.	LISTING	HP	VOLTS	SOLIDS SIZE (Dia. In.)	RUNNING AMPS/WATTS	PERFORMANCE (GPM @ HEAD)			SHUTOFF (Ft.)	PWR. CRD. P.S.I.	WEIGHT (Lbs.)	DIMENSIONS (H x L x W in.)	
							5'	10'	15'					
10S-CIM	511400	UL/CSA	1/2	115	2	12/1000	110	85	45	20	8.7	15	47	12.70 x 10.3x 8.25
10S-CIM	511501	UL/CSA	1/2	127	2	12/1000	150	100	54	20	8.7	15	44	12.70 x 10.3x 8.3
10S-CIM*	511450	UL/CSA	1/2	115	2	12/1000	110	85	45	20	8.7	15	49	12.70 x 10.3x 8.25
10S-CIM	511475	UL/CSA	1/2	208/230	2	6.6/1100	110	85	45	20	8.7	15	47	12.70 x 10.3x 8.25

* 3 inch Discharge

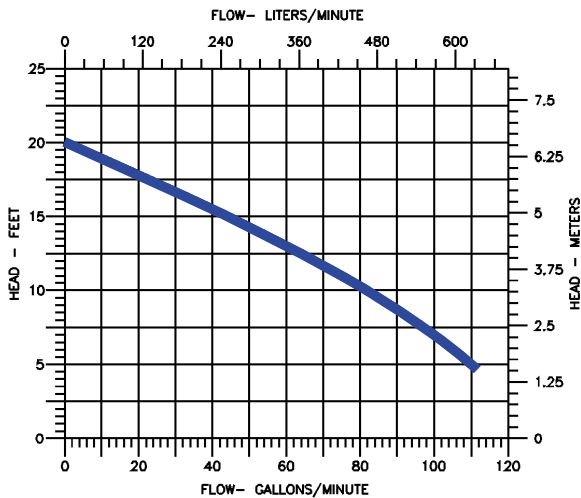

Construction

Motor Housing	Epoxy coated cast iron
Impeller Material	Nylon
Impeller Type	Vortex
Volute	Epoxy coated cast iron
Power Cord	SJTW
Mechanical Shaft Seal	Nitrile with carbon and ceramic faces
Fasteners	Stainless steel
Shaft	Steel
Bearings	Upper and lower ball bearings



ISO 9001 CERTIFIED

Little Giant Pump Co.

PO Box 12010
Okla. City, OK 73157

Phone: 405.947.2511
Fax: 405.951.5674

www.LittleGiantPump.com

Form No. 994344 - 02/01