

*Instruction Manual*

*AQUA JET*

*Wash Down Systems*

*WD 3.4 12/24 VDC*

*WD 5.0 12/24 VDC*

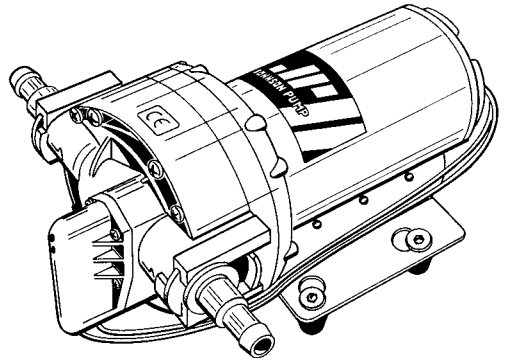

## Wash Down Systems 3.4 and 5.0 mounted to DC motor 12/24 V

### Typical applications

The WD 3.4 and the WD 5.0 are both five chamber positive displacement diaphragm pumps.

These pumps are the ideal choice for wash down applications as they provide 5 bar pressure (70psi), making clean-up faster and easier.

### Features

- Quiet operation
- Smooth flowing
- Self priming
- Integrated pressure switch turns pump on and off automatically when the spray nozzle is opened and closed
- Dry running without damage
- Low power consumption
- Quick disconnect fittings

### Working principle

As the pump runs, pressure builds until reaching 5 bar/ 70 psi. At this point, the integrated pressure switch automatically shuts the pump off.

The pump is equipped with positively checking outlet valves which ensure that the pressure is maintained after the pump shuts off.

When water is demanded the pressure decreases. After a moderate drop in pressure, the integrated pressure switch automatically turns the pump back on.

Due to their durable construction and thoughtful design, the WD 3.4 and the WD 5.0 pumps will provide many years of service.

Important! The pressure setting of this pump is made at the factory. Warranty invalidated by pressure switch interference.

### Technical description

Body:	Nylon
Valve housing:	Polypropylene
Valves:	Nitrile
Diaphragm:	Santoprene
Connection:	3/8" BSP, 1/2" hose (Ø 13 mm) or US: 1/2" NPT, 3/4" hose (Ø 13 mm) US: 3/4" Garden hose thread (GHT)

Max. liquid temperature:	Max +50°C/+120°F
Fasteners:	Stainless steel
Max. suction lift:	WD 3.4 – 2.5 m/8.2 ft WD 5.0 – 3 m/9.8 ft
Cut in pressure:	3.7 Bar/54 psi
Cut-off pressure:	5 Bar/70 psi
Duty cycle:	Intermittent, max 20 min
Motor:	WD 3.4 – 130 W WD 5.0 – 185 W 12/24 V DC with built in thermal protection

The motor is ignition protected according to ISO 8846 (Small craft – Electrical devices – Protection against ignition of surrounding flammable gases).

### Type designation

See page 39

## Pressure and capacity data

(based on water at +20°C/68°F and at full voltage of the motor)

### WD 3.4

Pressure Bar	kPa	psi	Flow l/min	USGPM	Amp. draw	
					12 V	24 V
0	0	0	13	3,4	2,3 A	1 A
0,5	50	7,3	12,1	3,2	3,3 A	1,4 A
1	100	14,5	10,9	2,9	4,5 A	2 A
1,5	150	21,8	10	2,6	5,5 A	2,5 A
2	200	29	9	2,4	6,4 A	2,8 A
2,5	250	36,3	8,3	2,2	7,2 A	3,2 A
3	300	43,5	7,5	2,0	8,1 A	3,6 A
3,5	350	50,8	6,8	1,8	8,9 A	4 A
4	400	58	6	1,6	9,7 A	4,4 A
4,5	450	65,3	5,3	1,4	11 A	4,8 A
5	500	72,5	4,5	1,2	11 A	5,1 A
Fuse required					15 A	8 A

### WD 5.0

Pressure Bar	kPa	psi	Flow l/min	USGPM	Amp. draw	
					12 V	24 V
0	0	0	18,9	5	3,6 A	1,7 A
0,5	50	7,3	17,8	4,7	5 A	2,4 A
1	100	14,5	16,6	4,4	6,6 A	3 A
1,5	150	21,8	15,5	4,1	7,8 A	3,6 A
2	200	29	14,5	3,8	9,1 A	4,2 A
2,5	250	36,3	13,4	3,5	10,4 A	4,8 A
3	300	43,5	12,4	3,3	11,7 A	5,2 A
3,5	350	50,8	11,4	3	13 A	5,7 A
4	400	58	10,6	2,8	13,8 A	6,2 A
4,5	450	65,3	9,7	2,6	14,8 A	6,5 A
5	500	72,5	8,7	2,3	15,9 A	7 A
Fuse required					20 A	10 A

## Installation and maintenance

### Installation

#### Locate the pump in a dry location.

If the pump is mounted vertically, the motor shall face up.

Mark screw positions and drill pilot holes (see drilling template page 45).

Mount the pump using stainless steel screws taking care not to over compress the vibration dampening rubber feet.

Reinforced, high pressure flexible tubing is recommended.

If rigid pipe is used, a length (225 mm/9 inches minimum) of flexible tubing shall be installed between the pump

and the rigid pipe. This will address noise and/or damage caused by vibration transmitted to rigid pipe.

Use stainless steel hose clamps to secure tubing to quick disconnect fittings and other hose bars in the system.

**The strainer that follows the pump must be installed** in line before the pump intake, to prevent debris from entering pump and interfering with proper functioning of valves.

### Electrical installation

The pump must be installed according to ISO 10133 (Small craft – Electrical system – Extra low voltage DC installation for continuous current). Note: The fuse must be ignition protected.

The motor is equipped with built in thermal protection to prevent the motor from overheating. The protection is automatically restored when the motor is cooled.

If the pump is connected with separate earth lead, this should be yellow/green and connected to the motor base.

See the wiring table (next page) for correct installation. Negative wire must be black.

Choose wire size in accordance with total wire length (see table next page).

The wire connections must be sealed with a marine sealant.

Note: Before installation with electrical control systems, check that equipment to be used is of sufficient rated capacity to accept amperage draw of motor. Low voltage will cause motor to overheat.

### Wiring table

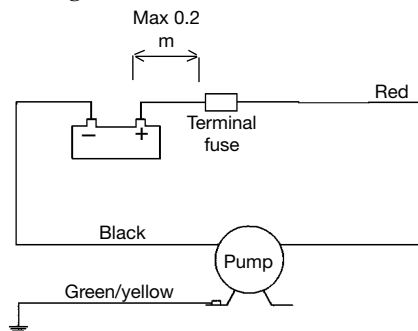

Other electrical devices, eg switch, circuit breaker, must be installed between the pump and the positive (+) lead on the battery (on the red wire).

### Wiring dimensions

(based on 3% voltage drop)

#### WD 3.4

Wire size	Max wirelength* in m	12 V 24 V	
		12 V	24 V
2.5 mm <sup>2</sup>	# 14 AWG	5.4	20.6
4 mm <sup>2</sup>	# 12 AWG	8.6	32.9
6 mm <sup>2</sup>	# 10 AWG	12.9	
10 mm <sup>2</sup>	# 6 AWG	21.4	
16 mm <sup>2</sup>	# 4 AWG	34.3	

#### WD 5.0

Wire size	Max wirelength* in m	12 V 24 V	
		12 V	24 V
2.5 mm <sup>2</sup>	# 14 AWG	3.9	17.6
4 mm <sup>2</sup>	# 12 AWG	6.2	28.2
6 mm <sup>2</sup>	# 10 AWG	9.3	42.3
10 mm <sup>2</sup>	# 6 AWG	15.5	
16 mm <sup>2</sup>	# 4 AWG	24.8	

\* The wire length is the total distance from the battery to the pump and back to the battery. It is recommended to use a relay with a light wire from main cable to switch to shorten the main leaders.

### Start-up procedure

After pump installation, the system can be started by using the following procedure:

- Make sure suction hose is connected to the water supply.
- Open the spray nozzle and start the pump.
- Close the spray nozzle when water begins flowing and all air has been purged from the system.
- If additional spray nozzles or taps are in use after the pump, open each additional nozzle/tap until all air has been purged from the system.
- Pump will cut off after taps are closed and pressure builds to the setpoint of the pressure switch

### Self-priming

Pump is self-priming up to 2.5 m/8.2 ft. for WD 3.4 and 3 m/9.8 ft. for WD 5.0. Intake lines must be air-tight to ensure self-priming.

### Dry running

Pump will not be damaged by shorter period of dry running. It will, however, unnecessary reduce your battery power.



### Caution

Do not use pump for any other liquids than fresh-water and sea-water.

### Temperature

Max liquid temperature: +50°C/+120°F  
Max ambient temperature: +60°C/+140°F

### Winterizing

If water is not drained from the system during freezing temperatures, damage is likely to be sustained in the plumbing and in the pump. To prevent damage follow the instructions beneath:

1. Disconnect suction hose from water supply (sea water supply) or if water supply is taken from a tank, drain water storage tank.

2. Open all spray nozzles/taps.
3. Run pump until remaining water is expelled.
4. Disconnect inlet and outlet tubes.
5. Run pump briefly to confirm that water has been expelled.
6. Spray nozzles/taps shall remain open and pump fittings shall remain disconnected until temperatures are above freezing

Never start a frozen pump. Even if it is drained it might contain a small amount of frozen water that locks the rotor.

## Service instructions (see page 42-43)

### Change of Switch (pos A)

1. Remove the screws (28) and then remove the complete switch including diaphragm (19).
2. Remove the cables (30 and 31) from the motor cable and power source.
3. Take the new switch and attach the cables to motor and power source.
4. Locate the new diaphragm (19) and then the new complete switch.

### Change of Diaphragm kit (pos B)

1. Remove the screws (18) with a Torx #20 tool (a standard Phillips type screw #20 tool). (Pos 18 screws should be fitted to the through holes which can be seen on the backside of the motor end bell).
2. Separate the pump assembly from motor.
3. Remove the screws (17) with a Torx #20 tool (a standard Phillips type screw #20 tool).
4. Hold the black pumpbody (14) towards the ground. Carefully remove the diaphragm kit (B) from pump body (14). Ensuring that pos 10-14 still remains together with pump body (14).
5. Locate the diaphragm kit into pump body (14) incl pos 10-14 and mount the five short screws (17) into the threaded holes in the motor flange.

6. Mount the complete pumphead kit onto the motor coupling flange taking notice to fit the slot in cam (5) in right position against motor shaft and the three slots on motor end bell.
7. Assemble the remaining long screws (18) which will hold the motor/pump unit together. (pos 18 screws should be fitted to the through holes that can be seen on the backside of the motor end bell).

### Change of complete Pump kit (pos C)

1. Remove the screws (28) and then remove complete switch including diaphragm (19).
2. Remove the cables pos (30 and 31) from the motor cable and power source.
3. Remove the screws (18) with a Torx #20 tool (a standard Phillips type screw #20 tool). (pos 18 screws has a through hole on the backside of the motor end bell).
4. Separate the pump assembly from the motor.
5. Mount the complete pumphead kit onto the motor coupling flange taking notice to fit the slot in cam (5) in right position against motor shaft and the three slots on the motor end bell.
6. Assemble the long screws (18) which will hold the motor/pump unit together. (pos 18 screws should be fitted to the through holes that can be seen on the backside of the motor end bell).
7. Locate the diaphragm (19) and then the complete switch.

## Accessories

See page 44

## Trouble-shooting chart

<i>Symptom</i>	<i>Cause</i>	<i>Remedy</i>
<b>1. Pump does not run.</b>	1.1 Tripped thermal protector or blown fuse.	1.1.1 Check fuse. If motor is overheated let it cool down prior to restart.
	1.2 Faulty wire connection or power source.	1.1.2 Check battery/power supply, main switch and wiring.
	1.3 Pressure switch malfunctioning.	1.1.3 Change pressure switch.
	1.4 Motor malfunctioning.	1.1.4 Change pump.
	1.5 Pump/motor frozen.	1.1.5 Thaw pump and system and check for damage. The pump/motor is liable to damage when a frozen pump is started
<b>2. Pump does not prime.</b>	2.1 Water tank empty.	2.1.1 Fill up tank.
	2.2 Debris under valves.	2.1.2 Carefully flush pump with tap water at nominal pump flow. Note! Flush in nominal flow direction.
	2.3 Perforated diaphragm.	2.1.3 Replace diaphragm kit.
	2.4 Leak on inlet side of pump.	2.1.4 Check tightness of hose connections at pump, filter and tank.
	2.5 Inlet or outlet plumbing restricted.	2.1.5 Check plumbing.
<b>3. Pump cycles on and off rapidly while water is demanded.</b>	3.1 Restriction on outlet side of pump/too high pressure.	3.1.1 Outlet hose too small, must be of same diameter as pump connection.
<b>4. Pump cycles on and off rapidly while water is not demanded.</b>	4.1 Leak on outlet side of pump.	4.1.1 Check tightness of hose connections, check hose for possible damage.
<b>5. Pump will not stop running when water is not demanded.</b>	5.1 Leak on inlet side of pump.	5.1.1 Check tightness of hose connections, check hose for possible damage.
	5.2 Leak on outlet side of pump.	5.1.2 Check tightness of hose connections, check hose for possible damage.
	5.3 Perforated diaphragm.	5.1.3 Replace diaphragm kit.
	5.4 Water tank empty	5.1.4 Fill up tank.
	5.5 Pressure switch malfunctioning.	5.1.5 Change pressure switch.
	5.6 Low voltage to pump.	5.1.6 Change battery/power supply.
<b>6. Low flow/pressure.</b>	6.1 Leak on inlet side of pump.	6.1.1 Check tightness of hose connections, check hose for possible damage.
	6.2 Leak on outlet side of pump.	6.1.2 Check tightness of hose connections, check hose for possible damage.
	6.3 Perforated diaphragm.	6.1.3 Replace diaphragm kit.
	6.4 Motor malfunction.	6.1.4 Change pump.
	6.5 Debris under valves.	6.1.5 Carefully flush pump with tap water at nominal pump flow. Note! Flush in nominal flow direction.
	<b>7. Pump is excessively noisy.</b>	7.1 Pump is plumbed directly to rigid tubing.
7.2 Pump head loose on motor.		7.1.2 Tighten screws.
7.3 Pump mounting is loose.		7.1.3 Tighten screws.
7.4 Pump mounting is too rigid.		7.1.4 Use flexible tubing and make sure the dampening rubber feet are used.
7.5 Defective motor.		7.1.5 Change pump.

**Dimensioner och vikter**  
**Dimensions and weights**  
**Abmessungen und Gewichte**

**Dimensions et poids**  
**Dimensiones y pesos**  
**Dimensioni e peso**

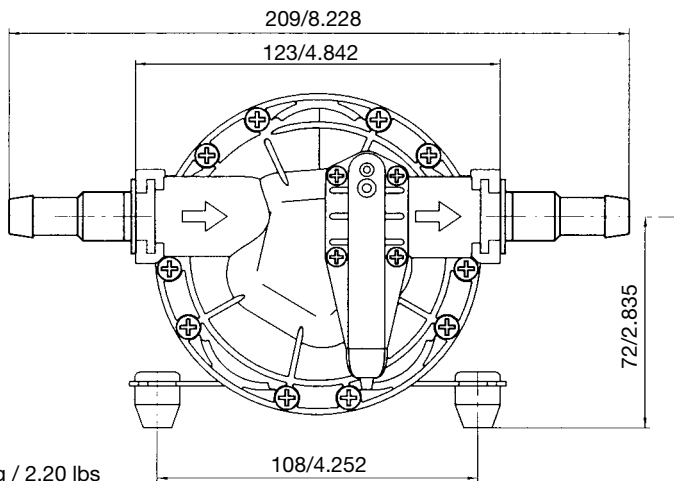

Vikt 2 kg  
Weight 2 kg / 2.20 lbs  
Gewicht 2 kg  
Poids 2 kg  
Peso 2 kg

Dim. mm/inches

# Reservdelslista

## Parts list

## Teilliste

# Liste des pièces Lista de piezas Elenco delle parti

Artikel Nr Part No Artikel Nr Part No Pieza No. Art. No	Pump typ Pump type Pumpe typ Modèle Tipo	<b>A</b> Brytare kpl Switch cpl Schalter kompl. Contacti complet Interruptor compl. Pressostato compl.	<b>B</b> Membransatz Diaphragm kit Membransatz Kit de diaphragme Juego de membrana Kit del diafragma	<b>C</b> Pumplus kpl Pump head kit Pumpensatz Cors de pompe complet Juego de cabezal de bomba Kit della testa della pompa	<b>15 a</b> Anslutningsatts x 2 3/4" hose/ 1/2" BSP Fittings x 2 3/4" hose/ 1/2" BSP Fittings x 2 3/4" hose/ 1/2" NPT Anschlüsse x 2 3/4" hose/ 1/2" BSP Kit de raccordement x 2 3/4" hose/ 1/2" BSP ones x 2 3/4" hose/ 1/2" BSP Raccordi x 2 3/4" hose/ 1/2" BSP	<b>2</b> Gummifuß x 4 Rubber foot x 4 Gummifuß x 4 Pied en caoutchouc x 4 Conexi/Pies de goma x 4 Prede di gomma x 4	<b>16</b> Låstring Fitting Retainer Sicherungstring Clips Reten Anello di fermo	<b>15 b</b> Anslutningsatts x 2 1/2" hose/ 3/8" BSP Fittings x 2 1/2" hose/ 3/8" BSP Fittings x 2 1/2" hose/ 3/8" NPT Anschlüsse x 2 1/2" hoses/ 3/8" BSP Kit de raccordement x 2 1/2" hose/ 3/8" BSP Conexiones x 2 1/2" hose/ 3/8" BSP Raccordi x 2 1/2" hose/ 3/8" BSP
--	--	--	--	---	---	--	---	--

Part No.	Pump Type	A	B	C	15 a	15 b	2	16	GHT*
10-13251-01/03	WD 3.4-12V/BSP	09-46779-02	09-46779-01	09-46782-03	09-46783	09-46784	09-46780	09-46956	-
10-13251-02/04	WD 3.4-24V/BSP	09-46781-02	09-46779-01	09-46782-03	09-46783	09-46784	09-46780	09-46956	-
10-13251-05/07	WD 5.0-12V/BSP	09-46781-02	09-46779-01	09-46782-03	09-46783	09-46784	09-46780	09-46956	-
10-13251-06/08	WD 5.0-12V/BSP	09-46781-02	09-46779-01	09-46782-03	09-46783	09-46784	09-46780	09-46956	-
10-13251-101/103	WD 3.4-12V/NPT	09-46781-02	09-46779-01	09-46782-03	09-46957	09-46958	09-46780	09-46956	09-46785
10-13251-102/104	WD 3.4-24V/NPT	09-46781-02	09-46779-01	09-46782-03	09-46957	09-46958	09-46780	09-46956	09-46785
10-13251-105/107	WD 5.0-12V/NPT	09-46781-02	09-46779-01	09-46782-03	09-46957	09-46958	09-46780	09-46956	09-46785
10-13251-106/108	WD 5.0-12V/NPT	09-46781-02	09-46779-01	09-46782-03	09-46957	09-46958	09-46780	09-46956	09-46785

GHT\* = Garden Hose Thread only US



**Pos A (19-31)**

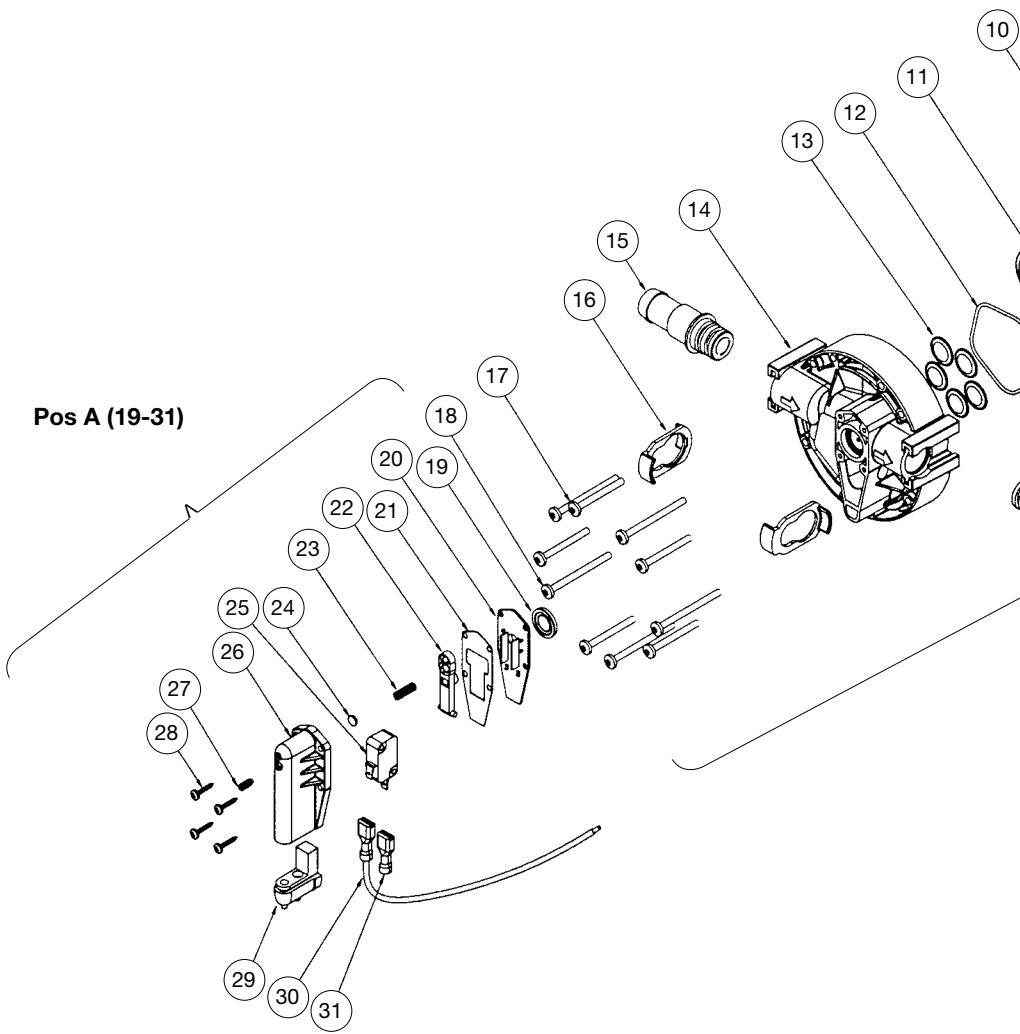

**Pos B (4-9)**

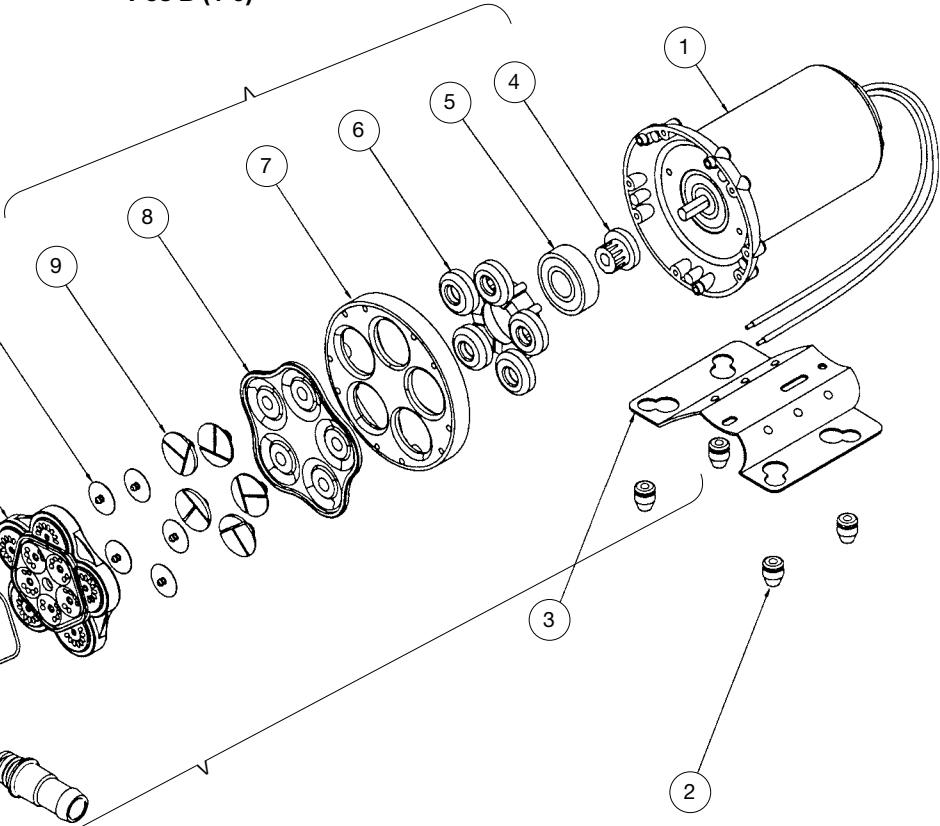

**Pos C (4-18 except 15)**

**Tillbehör**  
**Accessories**  
**Zubehör**

**Accessoires**  
**Accesorios**  
**Accessori**

**PUMProtector™ Universal Strainer**

Part. No	Mesh	KlickTite™ Connector
09-24652-01	40	2x 1/2" barb / 3/8" BSP 2x 3/4" barb / 1/2" BSP
09-24652-02	40	2x 1/2" barb / 3/8" NPT 2x 3/4" barb / 1/2" NPT
09-24652-03	20	2x 1/2" barb / 3/8" BSP 2x 3/4" barb / 1/2" BSP
09-24652-04	20	2x 1/2" barb / 3/8" NPT 2x 3/4" barb / 1/2" NPT

**PUMProtector™ Inlet Strainer**

Part. No	Mesh	KlickTite™ Connector
09-24653-01	40	Built-in KlickTite™ 1x 1/2" barb / 3/8" BSP 1x 3/4" barb / 1/2" BSP
09-24653-02	40	Built-in KlickTite™ 1x 1/2" barb / 3/8" NPT 1x 3/4" barb / 1/2" NPT
09-24653-03	40	Built-in KlickTite™ Bulk pack w/o connectors

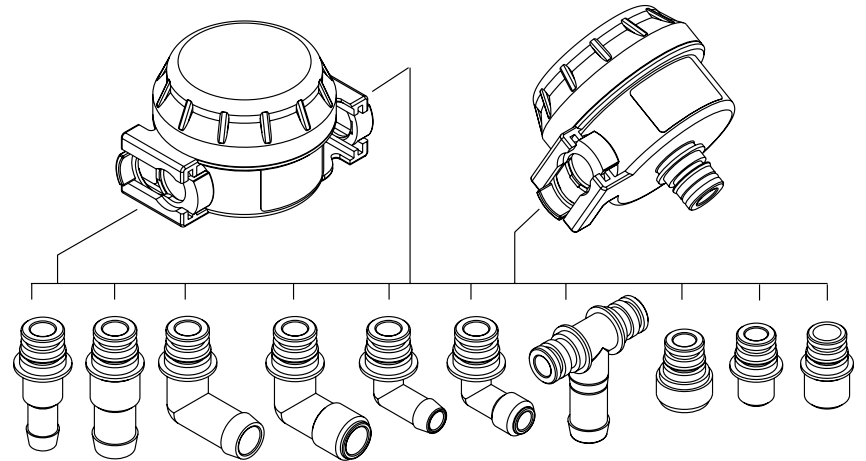

**KlickTite™ port connectors available**

Part. No.	Connector
09-46783	2 x 1/2" barb and 3/8" BSP
09-46784	2 x 3/4" barb and 1/2" BSP
09-46939	2 x 90°, 3/4" barb
09-47087	2 x 90°, 1/2" BSP
09-46938	2 x 90°, 1/2" barb
09-47026	2 x 90°, 3/8" BSP
09-46957	2 x 1/2" barb and 3/8" NPT

**KlickTite™ port connectors available**

Part. No.	Connector
09-46958	2 x 3/4" barb and 1/2" NPT
09-47088	2 x 90°, 1/2" NPT
09-47089	2 x 90°, 3/8" NPT
09-47092	1 x T-connection, 3/4" barb
09-47094	2 x Garden hose adapter
09-47096	2 x 3/8" BSP
09-47098	2 x 1/2" BSP

**Filter,  
 Inline-strainer,  
 Inline-Sieb,  
 Crépine de conduite d'arrivée,  
 Alcachofa de aspiración en línea,  
 Filtro del tubo d'entrada**

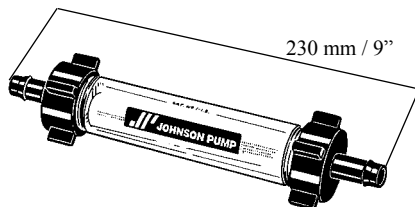

Hålschema 1:1

Hole layout 1:1

Lochsablonen 1:1

Schéma de perçage 1:1

Croquis agujeros 1:1

Schema per l'esecuzione dei fori 1:1

