

PAR MANUAL MARINE TOILET

MODEL : 59128-0000

Installation Operating and Service Instructions

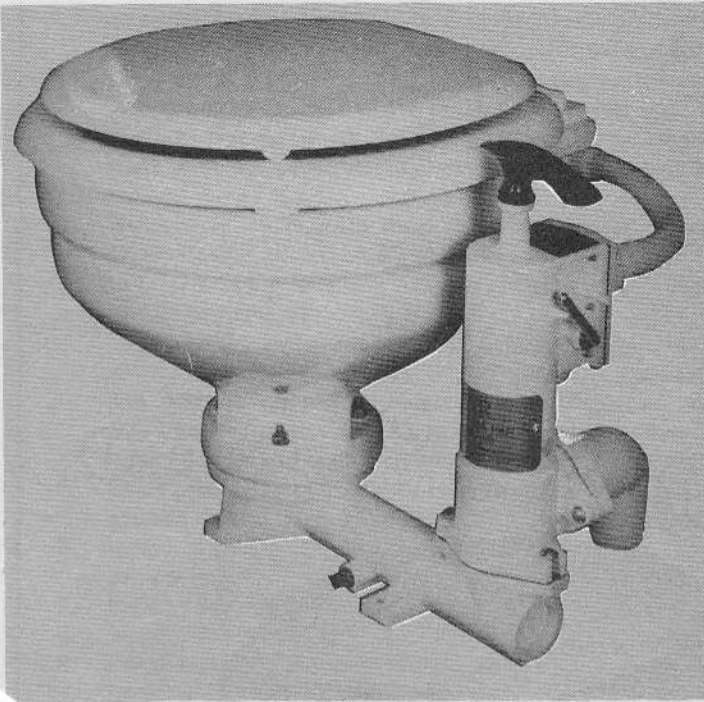

DESIGN FEATURES

- White Vitreous China Bowl
- Baked Enamel Seat and Cover
- Compact, Low Profile Design
- Smooth Action Pump for Easy Flushing and Pump Out
- Flush and Dry Bowl Valve for Minimum Water Usage
- Base and Pump of Tough Cyclocac Plastic
- All Stainless or Bronze Fastenings for Sea Water Service

Specifications

¾" Hose Inlet, 1½" Hose Outlet
12¾" High, 17¼" Wide, 16" Deep
Weight 23 lbs.

MODEL : 59128-0000

INSTALLATION INSTRUCTIONS

The PAR manual toilet may be installed above or below the waterline. Seacocks should be used for intake and discharge hull fittings. Securely fasten all four mounting feet on flat surface.

PLUMBING CONNECTIONS. Make sure all inlet connections are airtight and free of sharp bends or restrictions. Discharge hose should be as direct as possible and free of sharp bends or restrictions. Use heavy wall non-collapsible hose or tubing.

For installations below waterline, use vented loop in all discharge hoses about 8" above waterline at all angles of heel or trim. A vented loop can be installed between the bowl and pump outlet (fresh water) to protect below waterline installations.

For installations above waterline, make a loop in the discharge line about 8" above base of bowl to retain water in bowl.

OPERATING INSTRUCTIONS

Make sure inlet and discharge seacocks or valves are open. Move valve lever to "Flush" position and operate pump, return valve lever to "Dry Bowl" position and empty bowl. Leave valve lever in "Dry Bowl" position when toilet is not in use. Close seacocks when boat is unattended.

To drain for winter lay-up, remove drain plug in the base and operate pump with valve lever in dry bowl position. In salt water areas, a thorough flushing with fresh water will assure trouble-free use the following season. Do not use antifreeze or other chemicals.

ITT JABSCO

Form 43000-0020 Rev. 10/80

EXPLODED VIEW

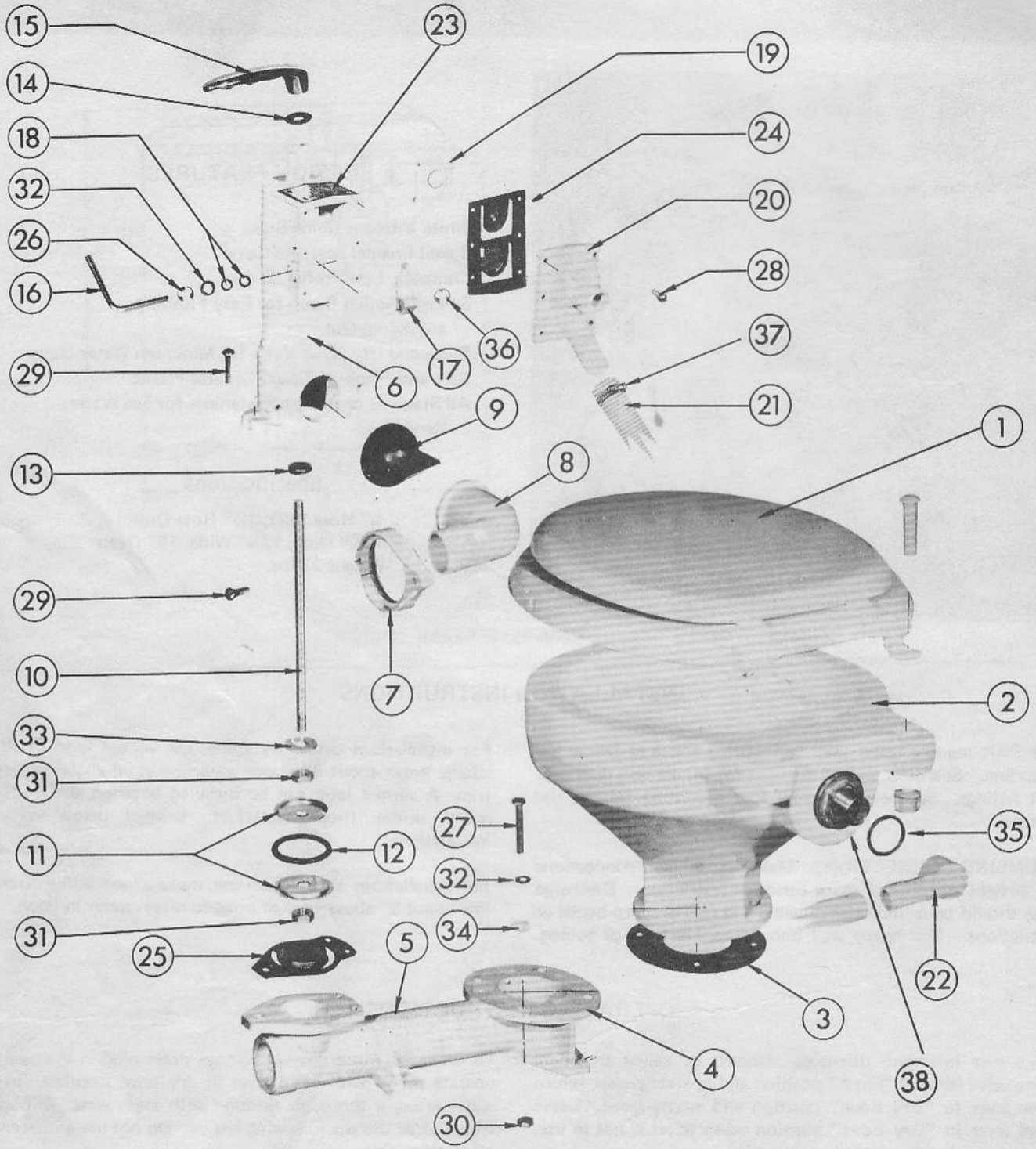

ASSEMBLY

1. Replace seal in the body making sure that the lip of the seal is facing piston end of the pump. This is done by sliding the seal on the piston shaft (10) and piston assembly. Insert the shaft into the pump body bore and slide up the pump bore until the handle (15) can be attached to the shaft. Slowly pull the handle and shaft through the handle end of pump body until the seal contacts the seal bore in pump body. Lightly tap the seal into the bore by repeatedly pulling the handle until it bottoms out or by tapping the piston (11) end of the shaft with a wooden dowel until the seal is completely seated.
2. Remove all burrs from piston end and shank of rod attach handle, slide bumper washer up against handle.
3. Lubricate pump bore and rod, insert rod from top until handle bottoms on bumper washer.
4. Slide washer over end of rod, tighten top nut with socket wrench, install top piston, lubricate 'O' ring and position on piston, locate bottom piston on rod and tighten bottom nut. Be sure 'O' ring is centered in piston flanges and sealing all around bore.
5. Check operation of pump to be sure piston slides freely and rod rotates easily in housing.
6. Install retaining ring, washer and 2 'O' rings on valve control handle.
7. Install valve control handle in pump body.
8. Install valve cam on shaft and secure with retaining ring.
9. Install intake valve seat in body.
10. Install double valve flap assembly on body with hinge at top.
11. Install valve cover on body with down port at bottom and secure with screws.
12. Install joker valve in discharge port.
13. Install discharge port on body (secure with clamp, screws and nuts).
14. Install base flap assembly on base with weight on top.
15. Install pump assembly on base and secure with screws.
16. Install bowl assembly on base and secure with nuts, bolts and washers.
17. Install elbow on bowl.
18. Install hose between elbow and pump connection.

DISASSEMBLY

1. Remove fresh water hose from top of pump.
2. Remove 4 bolts, washers and nuts and remove bowl assembly and gasket.
3. Remove 2 screws and clamp from discharge elbow and remove same.
4. Remove 6 screws from dry bowl valve cover and remove cover, valve assembly and intake valve seat.
5. Remove retaining ring from valve cam shaft and remove cam, then remove valve control handle and 'O' rings.
6. Remove 3 screws, and remove pump body and valve from base.
7. To remove handle, use socket wrench on piston nut and unscrew handle.
8. Push shaft on through and remove from bottom of pump body.
9. Remove nuts, piston and 'O' ring from shaft.
10. Remove seal from pump body by using a stiff wire or coat hanger. Flatten the wire end and bend it at 90° angle. This is done by inserting the wire from the piston end of the pump body and placing the flattened end behind the seal. Repeat this action on each side of the seal until seal pulls from the pump body.
11. Remove port elbow from bowl.
12. Remove nuts from seat and cover assembly and remove same.
13. Remove base plugs from base.

KEY	DESCRIPTION	PART NUMBER	QTY. REQ.	KEY	DESCRIPTION	PART NUMBER	QTY. REQ.
1	Seat & Cover	59127-7001	1	21	1" Vinyl Hose	59127-7029	1
2	Bowl	59127-7002	1	22	Intake Elbow	59127-7030	1
3	**Bowl Gasket	59127-7004	1	23	Dry Bowl Decal	59127-7033	1
4	Base	59128-7001	1	24	**Double Flap Valve Gasket	59127-7040	1
5	*1/4" Base Plug	59127-7006	1	25	**Base Flap Valve Gasket	59127-7041	1
6	Pump Cylinder	59127-7009	1	26	Retaining Ring	59127-7042	1
7	Discharge Flange	59127-7011	1	27	*1/4-20x1 1/2 Hex Head Bolt	57000-8395	4
8	Discharge Elbow	59127-7012	1	28	*3/4"xNo. 10 Round Hd. Screw	57000-8515	6
9	**Joker Valve	59127-7013	1	29	*1"xNo. 14 Round Hd. Screw	57000-8510	5
10	Piston Rod	59127-7014	1	30	*1/4-20 Brass Hex Nut	91085-0050	4
11	Piston	59127-7015	2	31	3/8-16 Brass Hex Nut	57000-8105	2
12	**Piston 'O' Ring	59127-7016	1	32	*1/4 Flat St. St. Washer	91603-0090	5
13	**Seal	59127-7017	1	33	3/8" Flat Brass Washer	57000-8160	1
14	**Bumper Washer	59127-7018	1	34	*11/16" Flat Plastic Washer	57000-8195	4
15	Pump Handle (Long)	59127-7019	1	35	Intake O-Ring	59127-7051	1
15A	Pump Handle (Round)	92330-0092	1	36	Cam Retaining Ring	59127-7052	1
16	Valve Control Handle	59127-7031	1	37	Hose Clamp	93002-0170	1
17	Valve Cam	59127-7021	1	38	Spud Assembly	59127-7057	1
18	'O' Ring Seal	59127-7023	2		Service Kit (Hardware)	59300-1001	
19	Intake Valve Seat	59127-7026	1		Service Kit (Gaskets)	59300-1002	
20	Valve Cover	59127-7027	1				

*Parts included in 59300-1001 Service Kit.

**Parts included in 59300-1002 Service Kit.

DIMENSIONAL DRAWING

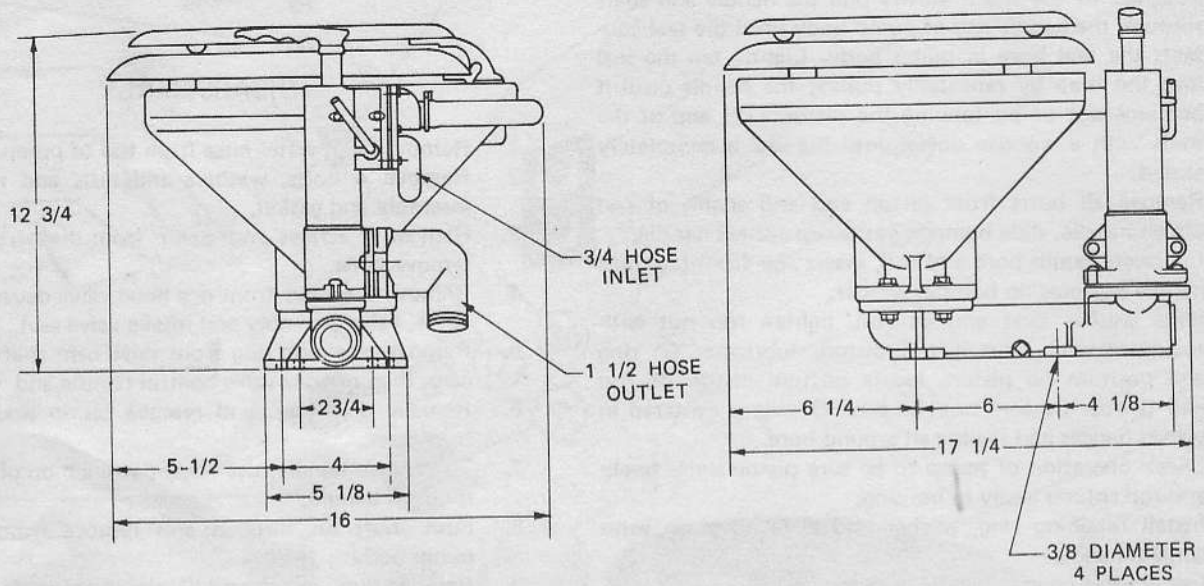

Model 59128-0000

ITT JABSCO

MARC Division

International Telephone and Telegraph Corporation

1485 Dale Way, Costa Mesa, California 92626

Telephone: (714) 545-8251