



010 Size Flexible Impeller AC Motor Pump Unit

2/99

53010 Series

Stainless Steel Flexible Impeller Pump

Features

- Self prime from dry up to 1.5 metres
- Flows up to 12 litres per minute
- Pressure up to 3.5 bar
- Handles hard or soft solids
- Tolerates abrasive wear
- Non pulsating flow
- Handles viscosities up to 500 centiPoise
- Uses standard IEC motor



Typical Applications

- **Industrial** : Industrial filling systems, utility shop pump, transfer systems, recharge water softeners, sump emptying, cooling tower circulation, line cleaning, heat exchangers, air scrubbers, laboratory circulation, oil changing.
- **Food, Beverage & Dairy** : Vending Machines, refrigeration condensate pump out, wash down equipment & floor cleaning.
- **Further applications** in the industrial, marine farming & plumbing sectors, see our Bronze range of Flexible Impeller pumps

Specifications

Seal : Mechanical face, Carbon on Ceramic. Butyl elastomers.

Pump Head : Stainless steel 316

End Cover : Stainless steel 316

Bearings : Uses motor bearings

Shafts : Stainless steel shaft extension

Ports : 1/2" BSP External

Motor Adaptor : Stainless steel, fixed to pump head

Weight : 6.3kg

Model Options

Impeller option				Neoprene 3A	Neoprene	Nitrile	Neoprene HT
Temperature range				4°C to 65°C	4°C to 80°C	-5°C to 90°C	4°C to 105°C
Poles	Volts	Amps	RPM				
4	230	2.13	1450	53010-2115	53010-2111	53010-2113	
2	230	1.88	2850	53010-02-2115			
4	115	4.20	1450	53010-03-2115			
Pump head only				53011-2115	53011-2111	53011-2113	

All motors are single phase, 180 Watt, 50 Hertz, AC. Face & Foot mounting B3-B14.

Enclosure IP55, frame size 63 all IEC 72 standard. Fitted with manual reset thermal overload.

Note : it is not recommended to start the pump at extreme ends of the temperature range, impeller damage may occur

For Installation, Operating, Maintenance and Safety Instructions refer to form 43001-0543

WARNING Explosion hazard. Do not pump gasoline, solvents, thinners or other flammable liquids. To do so can cause an explosion resulting in injury or death.



WARNING Fire hazard. Wiring must comply with applicable electrical standards and include a properly sized fuse or circuit breaker. Improper wiring can cause a fire resulting in injury or death.



JABSCO

010 Size Flexible Impeller AC Motor Pump Unit

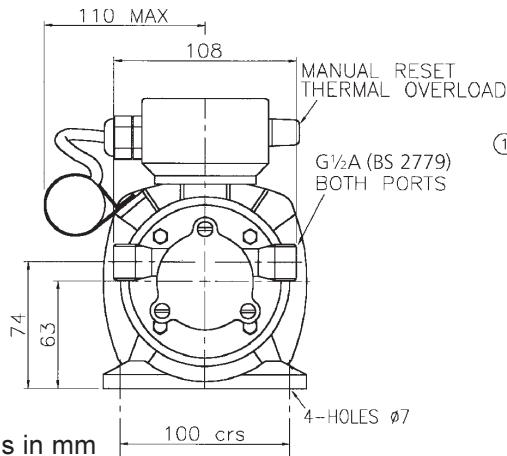
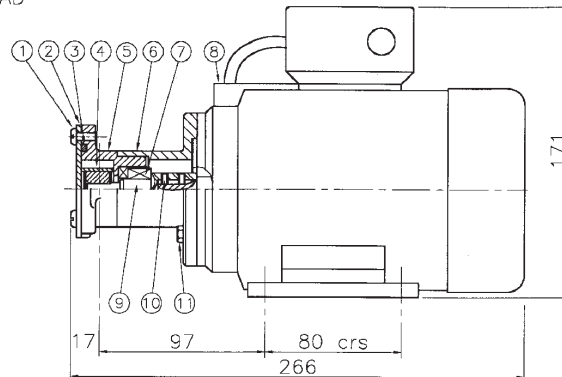
2/99**53010 Series**

Dimensions in mm

Parts List

Key	Description	Qty	Part Number
1	Screw *	3	X3002-151F
2	Endcover	1	11154-0020
3	O'Ring *	1	SP2000-58
4	Impeller	1	12298-0015
	Neoprene 3A	1	9200-0001
	Neoprene	1	9200-0003
	Nitrile	1	23250-0065
5	Body	1	22174-2100
6	Adaptor	1	53016-000
7	Seal Assembly *	1	SP8021-0301
8	Motor	1	SP8012-0260
	4 Pole 230V	1	SP8012-9266
	2 Pole 230V	1	98012-9279
9	Shaft Extension Kit	1	53017-0000
10	Set Screw	2	X3009-093F
11	Screw M4 x 16	4	X3001-153F
Parts marked * Contained in service kit			
Service Kit	Neoprene 3A	1	SK320
	Neoprene	1	SK320-02
	Nitrile	1	SK320-0113
	Neoprene HT	1	SK320-0115T

Motor Spares

Capacitor	1	X5501-033	
Fan Cowl	1	X5501-034	
Fan	1	X5501-035	
Foot	1	X5501-036	
Thermal overload switch	1	X5501-037	
Terminal box	1	X5501-038	
Screw	Terminal box	4	X5501-039

Performance

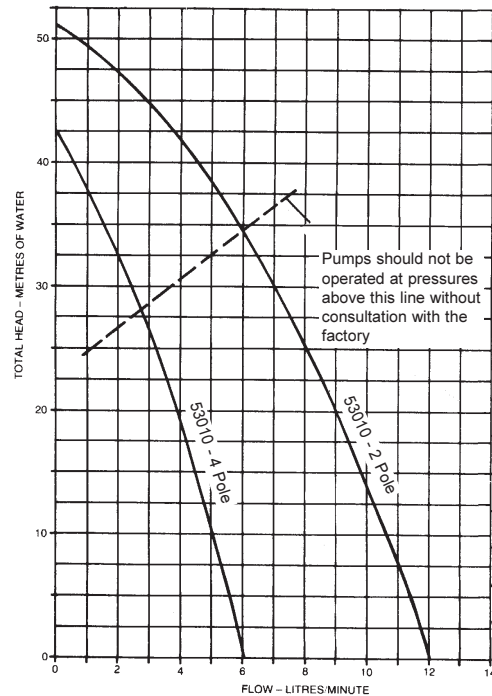

Note : Performance shown is for a new pump fitted with a Neoprene impeller pumping water at 20°C, performance may vary by up to 15%. Consult factory for performance of alternative impeller compounds.

Jabsco**ITT Industries****USA**

Jabsco
1485 Dale Way
Costa Mesa
CA 92628-2158

Tel : +1 714 545 8251
Fax : +1 714 957 0609

UK

Jabsco
Bingley Road
Hoddesdon
Hertfordshire, EN11 0BU

Tel : +44 (0) 1992 450 145
Fax : +44 (0) 1992 467 132

GERMANY

Jabsco GmbH
Oststraße 28
22844 Norderstedt

Tel : +49 (0) 40 53 53 73 0
Fax : +49 (0) 40 53 53 73 11