

JABSCO[®]

Models 45710-0000 45710-0020

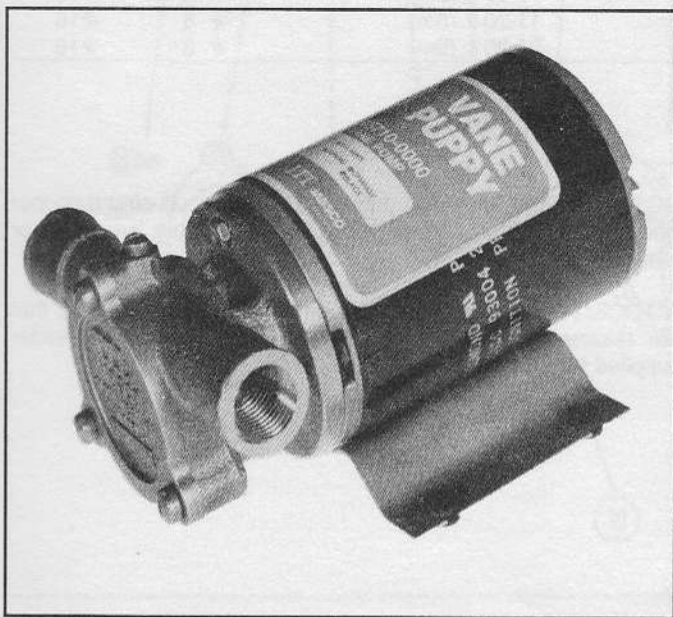

ROTARY VANE PUMP FEATURES

- Body:** Bronze
- Rotor:** VECTRA™* LCP
- Vanes:** VECTRA™* LCP
- Seal:** Lip Type, Nitrile
- Motor:** Permanent Magnet Type, Fully enclosed, Stainless Steel Shaft
- Ports:** ½ Inch Internal Pipe Threads
1 Inch External Hose Barb
- Height:** 3¾ Inches
- Length:** 6⅞ Inches
- Width:** 4¾ Inches
- Weight:** 5½ Pounds

MODELS AVAILABLE

- 45710-0000 12 Volt DC
- 45710-0020 32 Volt DC

Models 45710-0000, 45710-0020

WARNING: DO NOT OPERATE WITH RIVETS REMOVED FROM MOTOR CASE. EXPLOSION RESULTING IN PERSONAL INJURY, DEATH OR PROPERTY DAMAGE MAY OCCUR. CASE OPENINGS MUST BE SEALED TO AVOID EXPLOSION AND MAINTAIN IGNITION PROTECTED RATING.

Motor meets USCG Electrical Standards (Title 33, Chapter I, Part 183; Subpart I) for IGNITION PROTECTION on gasoline powered vessels. SEE WARNING Note.

APPLICATION

The Jabsco Rotary Vane pump is ideal for pumping oil or transferring diesel fuel. The vectra rotor and vectra vanes are not affected by petroleum products. It is self-priming with a suction lift of up to three feet and can pump against a discharge head of up to thirty feet.

WARNING: DO NOT PUMP VOLATILE LIQUIDS WITH A FLASH POINT BELOW 100°F (38°C). DOING SO MAY CAUSE AN EXPLOSION OR FIRE RESULTING IN INJURY OR DEATH.

Note: Diesel fuel has a flash point of 100° - 190°F (43° - 88°C).

PLUMBING CONNECTIONS

Pump ports have external 1" hose barb and internal ½" pipe threads. Use hose that does not kink when bent and with sufficient wall thickness to prevent collapse when used on suction side of pump. Hoses should be routed so that some fluid will be retained in pump body to wet the rotor and vanes. Wetting the rotor and vanes aids in priming. Use a strainer on the intake hose if debris or solids are present in the fluid being pumped. ALL HOSES MUST HAVE AIRTIGHT CONNECTIONS TO ENABLE FAST PRIMING.

INSTALLATION

The pump must be mounted in a dry location – the motor is not waterproof and must not be submerged. SELECTION OF A COOL, VENTILATED location will generally extend pump motor life. The unit can be mounted in any desired position. It is best to mount so that fluid dripping from a loose port connection will not wet the motor. The pump head may be mounted at 90 degree increments on the motor to allow mounting as needed.

PSI	TOTAL HEAD		CAPACITY	
	FEET	METRES	GPM	l/MIN
2.1	5	1,5	6.2	23,5
4.3	10	3,0	6.0	22,7
8.7	20	6,1	5.7	21,6
13.0	30	9,1	5.3	20,0

Table shows approximate Head-Flow for new pump.

* VECTRA™ is a registered trademark of Celanese Corporation.

ELECTRICAL CONNECTIONS

WARNING: EXPLOSION HAZARD. IF PUMP IS OPERATED IN AN AREA WHICH MAY CONTAIN FLAMMABLE VAPORS, WIRE LEADS MUST BE JOINED BY INSULATED MECHANICAL LOCKING CONNECTORS. LOOSE OR INADEQUATE WIRE CONNECTIONS CAN SPARK RESULTING IN AN EXPLOSION. PROPERTY DAMAGE, INJURY OR DEATH MAY OCCUR.

Connect black wire to negative (-) terminal of battery. The orange wire with the fuse holder should run to an overload protected switch or circuit breaker, with a wire from switch or breaker to positive (+) terminal of battery. Electrical circuit must be independent of all other accessories. A reversing switch (Jabsco model No. 96070-0110) may be used to reverse pump for intermittent duty cycles. Preferred motor rotation is clockwise looking at shaft end of motor. To prolong motor life, install pump so normal motor rotation is clockwise. Use proper wire size as determined by wire table elsewhere on this sheet. The proper fuse has been included in the fuse holder. Should this fuse blow, replace with the same size fuse after determining reason for blown fuse.

WIRING DIAGRAM

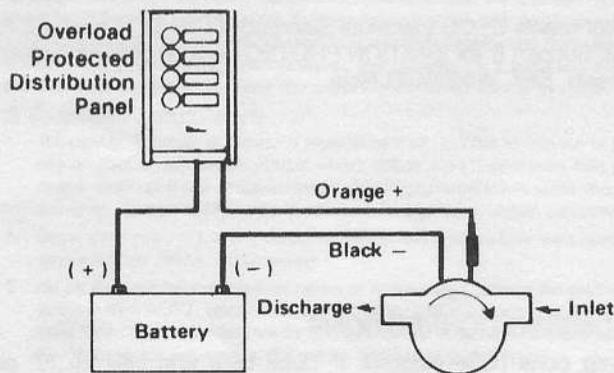

MINIMUM WIRE SIZES

CONNECTION LENGTH BETWEEN BATTERY AND MOTOR	12 V	32 V
1-10 ft. (3m)	#12	#16
11-20 ft. (6m)	# 8	#16
21-30 ft. (9m)	# 8	#16

NOTICE: To prevent motor damage, use only multi-strand copper wire in size recommended. DO NOT use ordinary lamp cord or other substitutes.

NOTICE: No warranty consideration will be given to pumps that are returned without the properly sized fuse and fuse holder supplied with the pump.

OPERATION

Rotary Vane pumps must NOT be run dry, as the pumped liquid is the lubricant for the rotor and vanes. Observe the outlet and shut off pump as soon as liquid stops flowing.

The pump cannot run against a closed outlet such as encountered when using a garden hose type shut-off nozzle. Pressure for normal operation should not exceed 20 feet of head (8.7 PSI). Excessive pressures will cause fuse to blow.

Temperature of pumped liquid may be in the range of 45°-165° F (10°-78° C).

MODELS	VOLTAGE	AMP DRAW	FUSE SIZE
45710-0000	12 Vdc	8	10 Slow Blow
45710-0020	32 Vdc	3	4 Slow Blow

EXPLODED VIEW

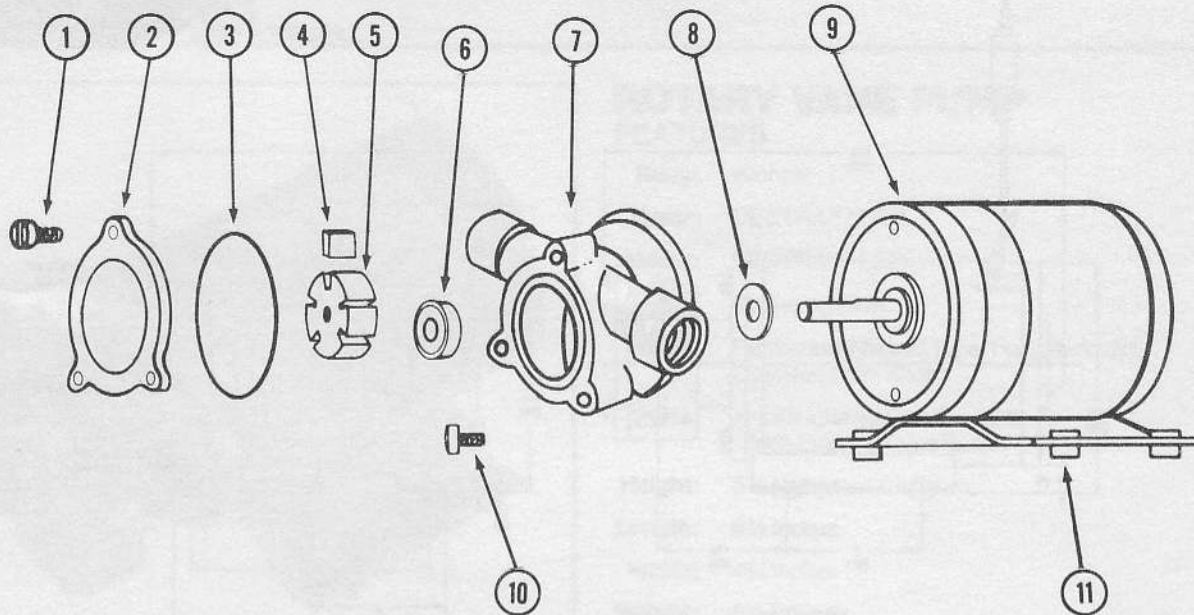

KEY	PART NUMBER	DESCRIPTION	QTY. REQ.
1	91004-0090	Screw (End Cover)	3
2	18753-0070	*End Cover	1
3	18753-0071	*O-Ring	1
4	18753-0072	*Vanes (set of 5)	1
5	18753-0073	*Rotor	1
6	93000-0100	*Seal	1
7	18753-0135	Body	1
8	6342-0000	Slinger	1
9		Motor	1
	18753-0050	Model 45710-1000 12Vdc	
	18753-0052	Model 45710-1020 32 Vdc	
10	98019-0020	Screw (Pump to Motor)	2
11	92900-0120	†Grommet	4
	90200-0000	Service Kit	

* Parts contained in Service Kit.
 † Parts supplied with Motor.

MAINTENANCE

Check wires and connections to be sure corrosion is not adding additional resistance to the motor circuit and causing a low voltage condition at the motor. Low voltage can inhibit motor from starting and cause fuse to blow. Full voltage should be available to prevent motor damage.

If pump is to be in freezing temperatures, drain by loosening end cover screws.

DISASSEMBLY

1. Remove end cover screws, end cover and O-ring.
2. Withdraw rotor and vanes.
3. Loosen and remove two slotted hex screws, which attach body to motor.
4. Tap body lightly between ports and remove body from motor.
5. Deform seal and remove from body cavity.

ASSEMBLY

1. Lubricate seal. Deform seal and install in cavity with open side of seal facing rotor/vane bore.
2. Lubricate motor shaft and install body on motor.
3. Aligning flat in rotor with flat on motor shaft, install rotor. Install vanes in vane slots of rotor.
4. Install O-ring, end cover and end cover screws.

DIMENSIONAL DRAWING
INCHES (MILLIMETRES)

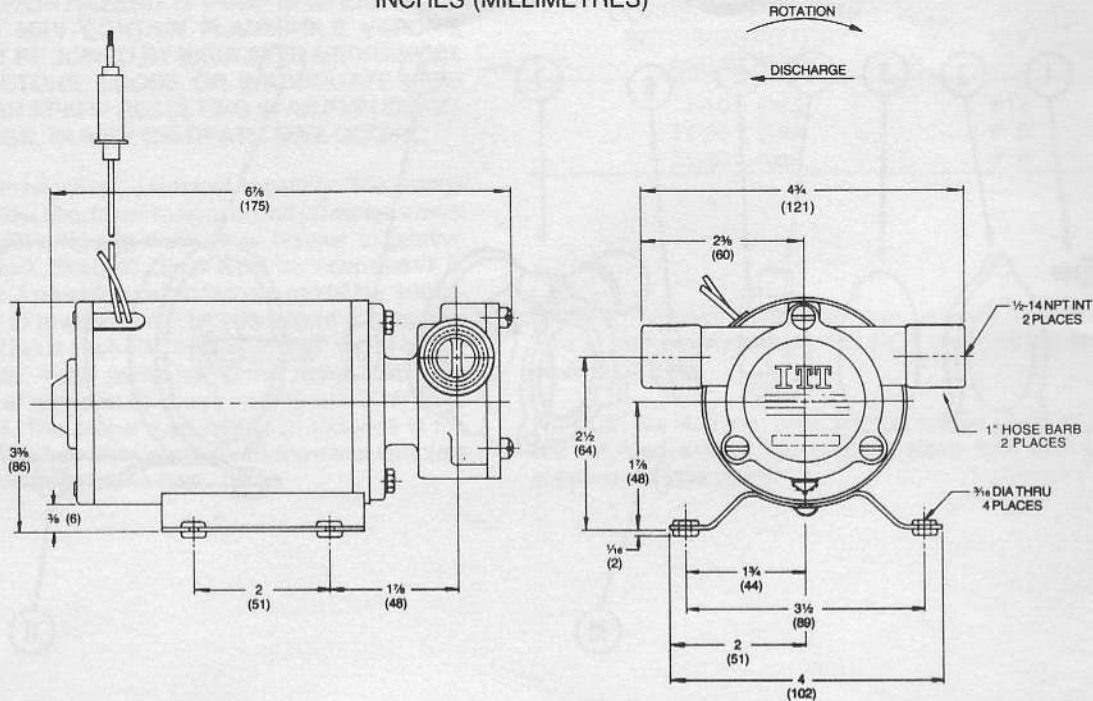

ONE YEAR LIMITED WARRANTY

A. WARRANTY: ITT warrants that at the time of shipment, the products manufactured by ITT and sold hereunder shall be in conformity with applicable written specifications and descriptions referred to or set forth herein, free from defects in material and workmanship, merchantable, and suitable for a particular purpose, provided such is implied by State law under the circumstances of this sale.

B. WARRANTY ADJUSTMENT:

1. ITT agrees to repair or furnish a replacement for, but not to remove or install, any product or component thereof which, within one (1) year from date of purchase, shall upon test and examination by ITT prove defective within the above warranty. Receipt verifying purchase date is required to obtain adjustment.
2. Buyer shall notify ITT of any defect within this warranty no later than ninety (90) days after the defect is discovered.
3. No product will be accepted for return or replacement without the prior written authorization of ITT. Upon such authorization, and in accordance with instructions from ITT, the product will be returned to ITT, shipping charges prepaid by Buyer. Products returned to ITT will be addressed as follows:

ITT JABSCO
1485 Dale Way
Costa Mesa, California 92626-3998

or to such alternate locations as may be designated
on the product, its container, or this sheet.

Repair or replacement made under this warranty will be shipped prepaid to Buyer.

C. EXCLUSIONS FROM WARRANTY:

1. The foregoing warranty is limited solely as set forth herein and applies only for the period designated above.
2. **ITT SHALL NOT BE LIABLE FOR ANY LOSS, DAMAGE, SPECIAL OR CONSEQUENTIAL DAMAGE OF ANY KIND, WHETHER BASED UPON WARRANTY, CONTRACT, NEGLIGENCE, OR STRICT LIABILITY ARISING IN CONNECTION WITH THE SALE, USE, OR REPAIR OF THE PRODUCT.**
3. **THE MAXIMUM LIABILITY OF ITT IN CONNECTION WITH THIS WARRANTY SHALL NOT IN ANY CASE EXCEED THE CONTRACT PRICE FOR THE PRODUCT CLAIMED TO BE DEFECTIVE OR UNSUITABLE.**
4. This warranty does not extend to any product manufactured by ITT which has been subjected to misuse, neglect, accident, improper installation, or use in violation of instructions furnished by ITT.
5. This warranty does not extend to or apply to any unit which has been repaired or altered at any place other than ITT's factory, or by persons not expressly approved by ITT, nor to any unit the serial number, model number, or identification of which has been removed, defaced or changed.
6. Components manufactured by any supplier other than ITT shall bear only that warranty made by the manufacturer of that product.
7. This warranty applies to products defined as "consumer products" by the Consumer Product Warranties Act as from time to time amended.

STANDARD WARRANTY: If the products manufactured and sold hereunder are not Consumer Products, the warranty extended to Buyer shall be as set forth in subparagraphs (a), (b), and (c), **EXCEPT THAT ALL EXPRESS OR IMPLIED WARRANTIES OR MERCHANTABILITY OR SUITABILITY FOR ANY PARTICULAR PURPOSE ARE EXCLUDED.**

ITT Jabsco
ITT Fluid Technology Corporation
1485 Dale Way, P.O. Box 2158
Costa Mesa, California 92628-2158
Telephone: (714) 545-8251
TELEX: 67-8357 ITT JABSCO CSMA
FAX: (714) 957-0609