



## Model 45510-1000

### TWO POSITION Y-VALVE

#### FEATURES

- Corrosion Resistant Polyester and Stainless Construction
- Includes Stainless Steel Locking Ring to secure valve in Holding Tank position
- Ideal for Marine Sewage and Bilge Pumpout Systems
- Full Port Openings

#### SPECIFICATIONS

Ports:	1-1/2" ID Hose
Body Material:	Polyester
Shipping Weight:	1.1 lb (0,5 kg)
Mounting:	No. 10 Screw (4)

#### APPLICATION

The Jabsco Y-Valve was designed for installation in on-board sewage handling systems and bilge evacuation systems.

**SEWERAGE SYSTEMS:** Current U.S. Coast Guard Marine Sanitation Regulations allow the boat operator to discharge untreated human waste when outside the 3 mile coastal limit. When the Y-Valve is installed in the holding tank discharge line (diagram 1), it allows the operator to choose between pumpout through a deck fitting or directly through the seacock.

IT IS IMPORTANT TO NOTE THAT IT IS ILLEGAL TO DISCHARGE SEWAGE EFFLUENT THAT IS NOT TREATED TO U.S. COAST GUARD STANDARDS WITHIN THE 3 MILE COASTAL LIMIT. IT IS NOT ILLEGAL TO HAVE A SYSTEM THAT ALLOWS OVERBOARD DISCHARGE OF UNTREATED SEWAGE INSTALLED ON BOARD A BOAT AS LONG AS OVERBOARD SYSTEM IS NOT USED WITHIN THE 3 MILE COASTAL LIMIT.

*Be environmentally responsible. Do not discharge waste in discharge restricted areas. Do not discharge bilge water contaminated with oil or fuel.*

When the Y-Valve is installed in the marine toilet discharge line (diagram 2) it allows the operator to choose between storing the toilet discharge effluent in the holding tank, or discharging directly overboard (when legal).

**BILGE SYSTEMS:** For boats with 2 separate bilge areas, the Y-Valve allows the operator to pump out either bilge section with only one pump. By simply selecting the appropriate valve selector lever either of the 2 bilges can be evacuated. (Diagram 3.)

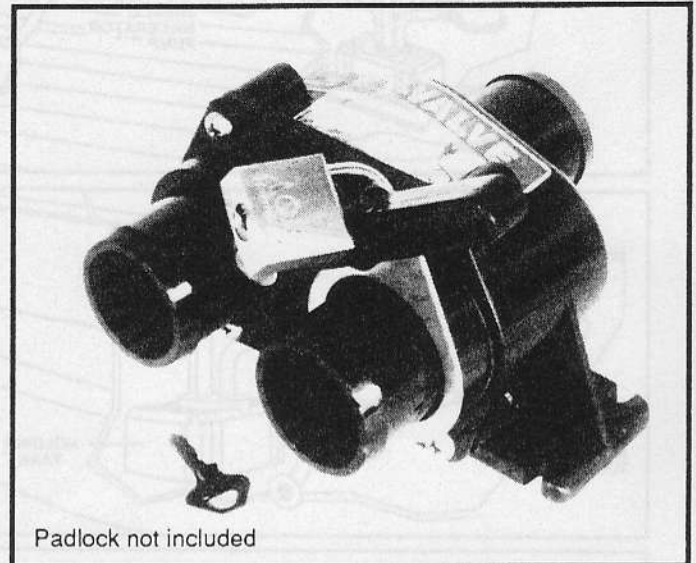

Padlock not included

Model 45510-1000

#### INSTALLATION

Lay out the system that the Y-Valve will be installed in so that all hoses can be installed without sharp bends, kinks or loops that trap fluids. After choosing a convenient, accessible location for the Y-Valve, be sure that there is adequate room to swing the selector lever. Mark locations for mounting screw holes. Be sure to choose a mounting location which is as flat as possible to prevent damage to the Y-Valve from mounting on uneven surfaces. Fasten the Y-Valve using #10 stainless steel fasteners. Before connecting hoses to the Y-Valve, position the selector lever locking ring on the port that is to be connected with the waste holding tank. This will allow the valve to be secured in the holding tank position with either a small padlock or wire seal when operating in no-discharge zones. Attach inlet and outlet hoses to the appropriate ports and secure with stainless steel band clamps.

It is recommended that all hoses used in waste systems should be the heavy, non-collapsible fabric reinforced hose. Vacuum cleaner type hose and vinyl hoses will collapse under the vacuum of a dockside pumpout system, or will allow sewer gas to permeate into the boat. All hoses should be double clamped with stainless steel band type clamps. Generally, sealing compounds are not necessary when making hose connections.

#### OPERATION

The Y-Valve is designed with a simple and positive diverter mechanism. When choosing the discharge hose system to use, simply orient the selector lever on the Y-Valve over the hose desired to be open to flow. When selecting the particular hose for flow, be sure that the lever is securely positioned against the positive stop. This will prevent bypass into the hose that has been chosen to be shut off. When fitted with a selector lever locking ring, the lever may be secured in the holding tank position by inserting a small padlock\* (with 1/4" or smaller shackle) through the hole in the locking ring and the hole in the selector lever.

\* padlock not included

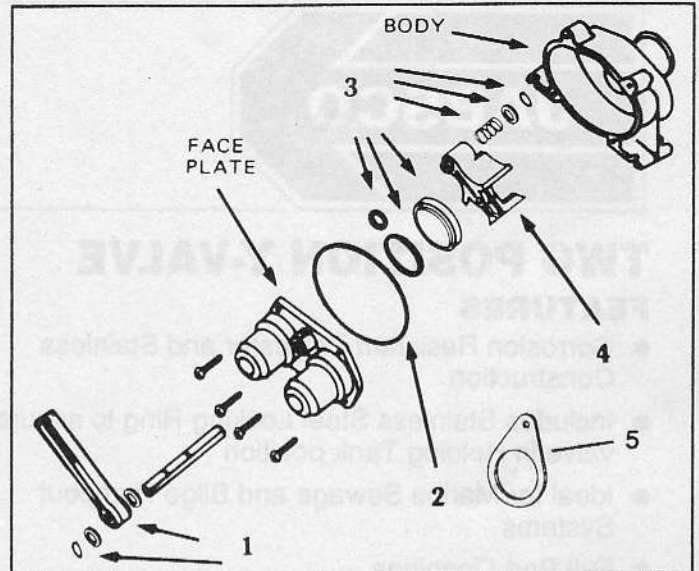
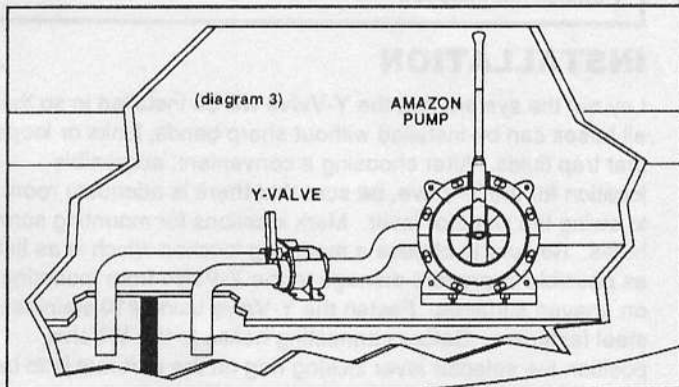
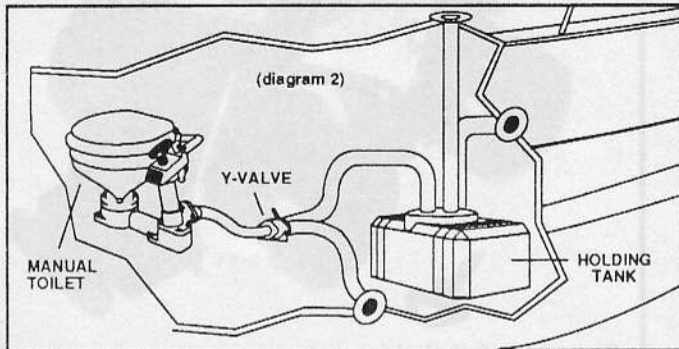
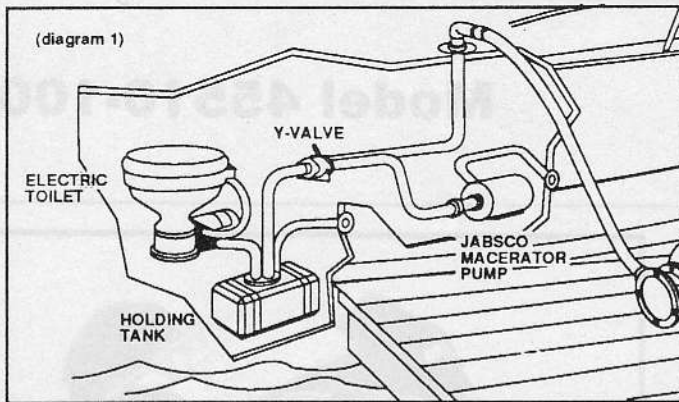

## PARTS LIST

Key	Description	Part Number	Qty.
1	Selector Lever <sup>1</sup>	45559-0000	1
2	O-Ring Gasket	45559-0001	1
3	Valve Seal Mechanism <sup>2</sup>	45559-0002	1
4	Swivel Block	45559-0003	1
5	Locking Ring <sup>3</sup>	45507-0001	1

<sup>1</sup> Includes Shaft Spring Retainer

<sup>2</sup> Includes Seal Disk and O-Ring, Shaft O-Ring, Shaft Spring, Shaft Snap Ring

<sup>3</sup> To update an old style Y-Valve, order both a locking ring and selector lever-part numbers 45507-0001 and 45559-0000.

## MAINTENANCE

If the Y-Valve becomes damaged or clogged with debris during service, it will be necessary to disassemble the unit. Empty all hoses and the Y-Valve of waste liquids and thoroughly flush the system with clean water. Re-flush the system with a water and bactericide mixture and flush again with clean water.

Remove all hoses from the Y-Valve and remove the Y-Valve to an area where it can be conveniently disassembled. Remove the 4 screws located on the face plate. Remove face plate and shaft/handle assembly from body. Remove all debris from the valve and inspect for damaged components.

If any parts of the shaft/handle, or port seal assembly need to be replaced, the shaft/handle assembly must be disassembled. **DO NOT REMOVE THE RETAINING RING AT THE SPRING END OF THE SHAFT.** Remove the retaining ring at the handle end of the shaft. SLIDE the handle and washers off the shaft and slide shaft and swivel block out of the bore in the face plate. Replace all damaged parts and reassemble items on the shaft. The spring must be compressed to allow the retainer ring to snap into the slot on the shaft. Reassemble the Y-Valve and reinstall in the waste system. **CHECK SYSTEM FOR LEAKS.**

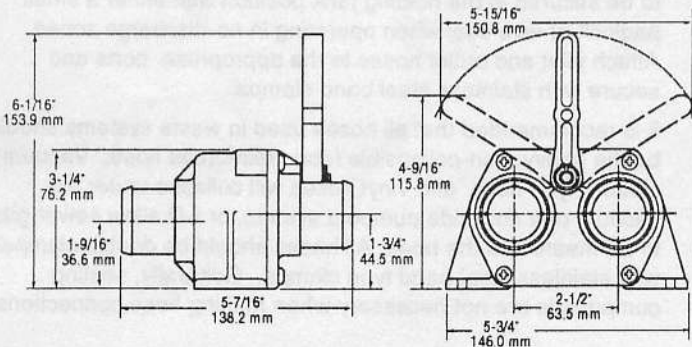

THE PRODUCT DESCRIBED HEREIN IS SUBJECT TO THE JABSCO ONE YEAR LIMITED WARRANTY, WHICH IS AVAILABLE FOR YOUR INSPECTION UPON REQUEST.



## ITT Jabsco

A unit of ITT Fluid Technology Corporation

U.S.A.  
ITT Jabsco  
1485 Dale Way, P.O. Box 2158  
Costa Mesa, CA 92628-2158

UNITED KINGDOM  
ITT Jabsco  
Bingley Road, Hoddesdon  
Hertfordshire EN11 0BU

CANADA  
ITT Fluid Products  
55 Royal Road  
Guelph, Ontario N1H 1T1

JAPAN  
NHK Jabsco Company Ltd.  
3-21-10, Shin-Yokohama  
Kohoku-Ku, Yokohama, 222

GERMANY  
MINTEC GmbH  
Oststrasse 28  
22844 Norderstedt