



Model 37215-Series

ELECTRIC WATER SYSTEM PUMPS

Automatic Multi-Fixture

FEATURES

- Self-Priming
- Diaphragm Design Allows Dry Running
- Built-in Discharge Check Valve
- Low Current Draw
- Built-in Hydraulic Pulsation Dampener
- Meets USCG Electrical Regulation Title 33, Chapter I, Part 183, Subpart I



Model 37215-Series

APPLICATION

A PAR automatic water system pump designed for smaller, self contained recreational vehicles and pleasure boats. This pump is automatic – when a faucet is opened, the pump begins operation instantly to provide a constant flow from tank to faucet. Closing the faucet automatically discontinues pump operation. The Model 37215-Series pump is especially suited for small distribution systems.

SPECIFICATIONS

	U.S. GPM	Liters/min.	Imp. GPM
Open Flow:	2.1	7.9	1.7

Cut-in Pressure: (Nominal) 20psi (138kPA)

Cut-off Pressure: (Nominal) 40psi (276kPA)

Ports: Slip-on 1/2" or 5/8" ID Hose

Vert. Dry Suction Lift: 5 feet (1, 52M)

Approx. Ship. Weight: 5 lb (2,3 kg)

DIMENSIONAL DRAWING

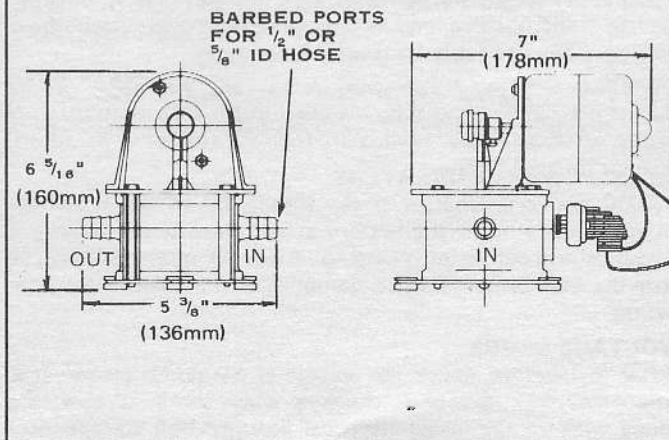

STANDARD MODELS

MODEL	VOLTAGE	NOM. AMP DRAW	FUSE RATING
37215-1000	12VDC	5.5	7Amp
37215-1010	24VDC	4.0	5 Amp

INSTALLATION

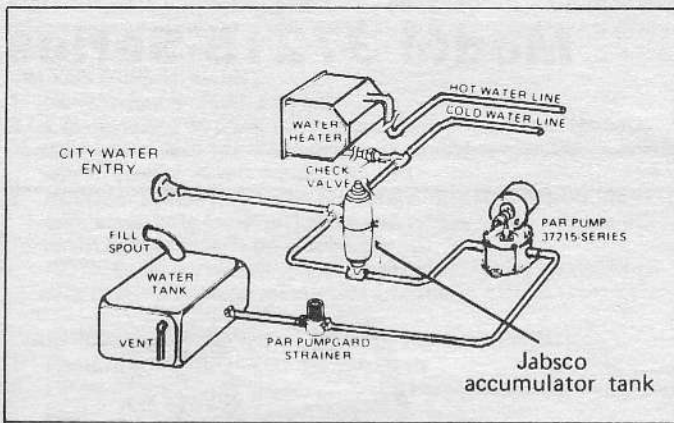

MOUNTING

PAR diaphragm pumps are self-priming. They may be located above or below the fresh water tank. The pump is equipped with vibration pads which are most effective when the pump is mounted upright on a solid surface.

PLUMBING

To minimize water pressure drop, the size of water supply line should not be less than sizes shown in the table below. Valves, elbows, etc., used should be the same size as pipe or tubing. Use gate valves only. Fresh water tank must be vented.

MINIMUM PIPING SIZE

Supply Line Length	Tubing I.D.	Pipe Size
Less than 48"	1/2"	3/8"
48" or more	5/8"	1/2"

PRESSURE REGULATOR. It is recommended that systems having a connection for a city water entry be equipped with a pressure regulating check valve set at approximately 35 PSI. This valve automatically regulates the incoming water pressure to avoid damage to the pump and plumbing from excessive pressures. PAR Models 44410-1000 (permanent flush mount) and 44410-1010 (in-line) pressure regulating valves are recommended for this purpose.

CHECK VALVE

PAR pumps are designed to withstand normal working pressures. However, higher pressures are sometimes encountered with unregulated water hookups. Models 37215-1000/-1010 features a built-in port check valve to protect the pump. An additional check valve should be installed in the cold water inlet of the water heater to minimize heat transfer to the cold water line and isolate excessive pressure from the heater in case of relief valve failure. PAR offers qualified check valves, Models 34344-0000, 35027-0000, and 35195-0000.

SUCTION FILTER. A PAR Pumpgard Model 36400-0000 (strainer/filter) is recommended installed between the pump and fresh water tank. It helps prevent valve clogging caused by foreign material entering the pump.

WATER PURIFIER. Water purifiers should be installed with separate outlets for drinking water use only. Many purifiers cause excessive back pressure.

ACCUMULATOR TANK. The use of an accumulator tank (Jabsco Model 12573-2000 or 18810-0000), although not required, is recommended for a more effective water distribution system. It eliminates "water hammer," stores pressures to allow a limited use of water without restarting pump (desirable at night-time), assures a constant, even stream of water at faucets farthest from pump and prolongs pump life by cutting down rapid start/stop operation.

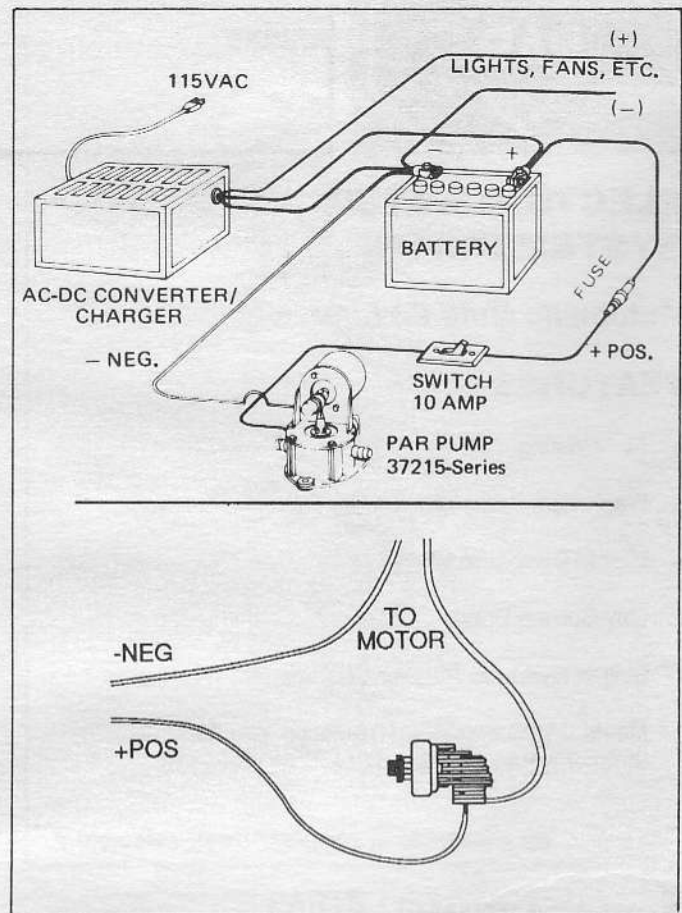

WIRING

Pump should be wired in an independent circuit according to the following chart:

WIRE SIZE CHART (A.W.G. - COPPER)

Length of circuit in feet (sum of + pos. & - neg. wire lengths).

Voltage	Up to 80'	80' to 100'	100' to 150'
12 Volts Two Wire	14	12	10
24 Volts Two Wire	16	14	14

Above wire size recommendation is based on pump load only. If other electrical fixtures share common service with the pump, larger wire sizes must be used.

MOTOR PROTECTION

The pump wiring must include a fuse or equivalent protective device in the positive lead to protect against overcurrent draw. See specification table for proper fuse rating.

SWITCH

An on-off switch should be installed in the circuit to turn off pump when vehicle or boat is unattended, stored, or in transit.

AC-DC POWER CONVERTERS

AC-DC converter/charger packs should be wired to operate pump directly from the battery at all times. If the battery is bypassed and converter is used to service the pump directly, be sure the total electrical loads do not exceed the converter Amp rating.

VOLTAGE CHECK

After installation, check the voltage at the pump motor. It is important that voltage is checked when pump is operating along with all the inside electrical fixtures. Full voltage must be available at the pump motor at all times.

OPERATION

- Check level of water in tank.
- Check all strainers or any aerators and clean thoroughly.
- Open all faucets, hot and cold.
- Turn on power to pump and wait for hot water tank and water lines to fill.
- Close each faucet when it starts to deliver a steady stream of water (close cold water faucet first).
- Observe the pump. Check to be sure pump stops soon after closing last faucet.
- Pump is now ready for automatic operation. It will start when a faucet is opened and stop when the faucet is closed.
- Turn off pump and relieve system pressure before hooking up to city water or prior to leaving pump idle.

MAINTENANCE

WINTER STORAGE. PAR pumps, with their unique pulsation dampener, will withstand frozen water without damage, provided the system is not under pressure prior to freezing. To prevent accidental damage, the entire water system should be protected from freezing during winter storage. This requires complete draining, using the following directions and/or vehicle manufacturers instructions:

1. Open all faucets and drains and allow pump to empty water tank and intake line. Run the pump dry for 1 to 2 minutes before turning off.
2. With all drains open, blow air through city water entry. Allow time for the water heater to empty.
3. Disconnect discharge and intake hoses from the pump. Start the pump and allow to run until all water is expelled from unit. (Running dry will not harm the pump.)
4. Reconnect the hoses, close the drains but leave faucets open. The water distribution system is now dry and ready for winter storage.

An alternate method is to use **POTABLE WATER SYSTEM ANTI-FREEZE** solution. Follow directions from anti-freeze manufacturer.

⚠ WARNING Do not use automotive type anti-freeze. It is poisonous and can cause illness or death.

TROUBLE SHOOTING

Problems

Pump operates but no water flows through faucet

Pump cycles on and off although all faucets are closed.

Pump operates roughly and has excessive noise and vibration.

Pump fails to start when faucet is opened.

Pump fails to stop when faucets are closed.

Causes

- Low water level in tank.
- Suction line clogged or kinked.
- Loose hose clamps or fittings in suction line.
- Water leak in plumbing.
- Water leak in flush toilet valve.
- Internal leak in pump.
- Outlet valve not sealing.
- Flow through intake line is restricted, kink in hose.
- Pump mounted on flimsy board.
- Deformed or ruptured pulsation dampener in pump.
- Worn connecting rod bearing.
- No voltage to pump.
- Blown fuse.
- Clogged piping.
- Kink in outlet line.
- Defective pressure switch.
- Empty water tank.
- Outlet valve not sealing.
- Air in system.
- Very low voltage.
- Defective pressure switch.

SERVICE

NOTICE: Before servicing pump, turn off power and open faucets to relieve pressure in water system. Failure to do so may cause flooding.

VALVES REPLACEMENT

1. Remove four tie down screws.
2. Expose valves by lifting motor mount from pump base. Remove valves from pockets. Clean all foreign materials from valves and seats. Inspect rubber flappers for cuts.
3. Reinstall valves into same pockets, being sure rubber valve with small hole is UP on intake and rubber valve without the small hole is DOWN on discharge.

NOTICE: Do not use valve with small hole in rubber on discharge side of pump or pump will operate incorrectly.

DIAPHRAGM AND CONNECTING ROD REPLACEMENT

1. Remove four motor mount tie down bolts.
2. Lift motor mount and the attached diaphragm assembly from pump base.
3. Remove two diaphragm retainer screws and the diaphragm retainer.
4. Pull connecting rod assembly and diaphragm from motor mount, then, unscrew bolt to separate diaphragm plates.
5. Loosely reassemble new diaphragm, diaphragm plates, washer and diaphragm bolt onto new connecting rod assembly.
6. Slide connecting rod on shaft. Ensure that eccentric is firmly seated on motor shaft and tighten set screw firmly against flat side of shaft.
7. Tighten connecting rod bolt while maintaining alignment of rod bearing eccentric. **NOTICE:** Avoid misalignment or twisting of rod on eccentric shaft or excessive bearing wear will result.

PULSATION DAMPENER REPLACEMENT

1. Remove four tie down screws and one bottom plate screw to separate bottom plate from base.
2. Pull out rubber pulsation dampener from base. Inspect for excessive deformation, ruptures and cuts.
3. When installing new dampener, check that its three-rib section is placed in the discharge side of the pump. Be sure that flange is well-seated to effect a proper water and air sea.

SWITCH REPLACEMENT – PROCEDURE A

Direct replacement of switch with threaded stem directly into pump body.

1. Disconnect power leads from switch and remove switch from pump.
2. Moisten rubber side washer with water. Thread washer onto switch threads with metallic side of washer facing switch. Apply a thin film of sealing compound to the replacement switch threads. Keep compound clear of passage-way hole.
3. Screw replacement switch into pump base/body until snug.
4. Reconnect switch power leads.

SWITCH REPLACEMENT – PROCEDURE B

For pump base-body with flange mount and two screw holes only.

1. Disconnect power leads from switch. Remove two screws on switch flange and save. **CAREFUL:** These screws hold down a strong spring. Remove switch housing, spring, plunger, and diaphragm from base/body.
2. Remove stem, retainer, and screws from switch and discard leaving switch housing, spring, plunger, and diaphragm.
3. Insert plunger and spring assembly into base/body noting stack-up in diagram.
4. Cover with switch housing assembly. Hold firmly and retain with two screws saved from old switch.
5. Reconnect switch power leads.

MOTOR REPLACEMENT

1. Disconnect one motor wire from pressure switch terminal, the other from splice connector.
2. Loosen eccentric set-screw on motor shaft.
3. Remove two motor nuts and pull motor away from motor mount, while holding back eccentric/connecting rod assembly.
4. When installing new motor, adjust eccentric on motor shaft so little or no contact is made between teflon washer and connecting rod bearing.
5. Rewire motor leads to terminal on pressure switch, and splice connector.

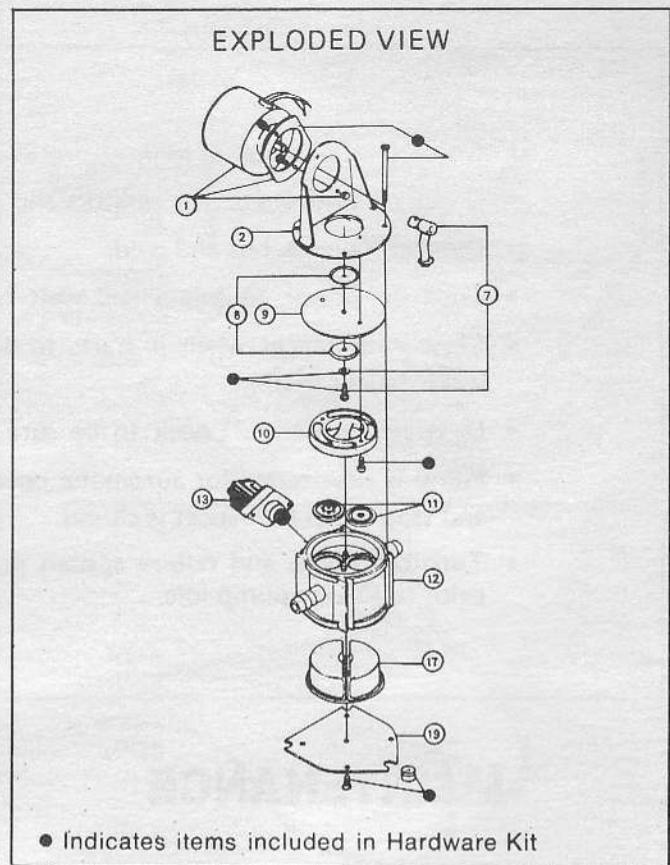

PARTS LIST

37215-Series

Key	Part Description	Part Number	Qty
1	Motor Kit 12 Volt D.C.	30201-0000	1
1	Motor Kit 24 Volt D.C.	30201-0010	1
2	Motor Mount	35812-0000	1
7	Connecting Rod Assembly	30033-0000*	1
8	Diaphragm Plate	35479-0000	2
9	Diaphragm	37174-0000*	1
10	Retainer	35799-0000	1
11	Valve Set (Inlet & Outlet)	30130-0000*	1 Set
12	Base	35787-1000	1
13	Pressure Switch	37121-0000—See Note 2	1
		37121-0010—See Note 3	1
17	Pulsation Dampener	37179-0000*	1
19	Bottom Plate	35798-0000	1
	Hardware Kit	37168-0000	1 Set
	Service Kit*	30127-0000	1

* Indicates Parts Contained in Service Kit.

NOTE 2 — Includes Switch and Conversion Kit to Mount New Style Onto Older Style -J and -0000 Pumps.

NOTE 3 — Replacement Switch Only for -1000 Series Pumps. Meets USCG Electrical Standards

ITT Jabsco

ITT Fluid Technology Corporation
 1485 Dale Way, P.O. Box 2158, Costa Mesa, CA 92628-2158
 Tel: (714) 545-8251; Fax: (714) 957-0609
 Bingley Road, Hoddesdon, Hertfordshire EN11 0BU England
 Tel: 0992-467191; Tlx: 263251 G; Fax: 0992-467132

THE PRODUCTS DESCRIBED HEREIN ARE SUBJECT TO THE JABSCO® ONE YEAR LIMITED WARRANTY, WHICH IS AVAILABLE FOR YOUR INSPECTION UPON REQUEST.