



**Model 37205-0000**

## **ELECTRIC WATER SYSTEM PUMP**

*Single Outlet, Manually Operated*

### **FEATURES**

- Self-priming
- Diaphragm Design Allows Dry Running
- Built-in Hydraulic Pulsation Dampener
- Meets USCG Electrical Requirements

### **SPECIFICATIONS**

Open Flow:	US 1.7 GPM (6,4 LPM)
Voltage:	12 Volt dc
Amp. Draw:	5 Amps Nominal
Vertical Dry Suction Lift:	5 Feet (1,52 m)
Ports:	Slip-on 1/2" or 5/8" ID Hose
Shipping Weight:	5 lb (2,3 kg) approx.
Fuse Rating:	7 Amp Normal

### **APPLICATIONS**

This Jabsco water system pump is designed for single outlet water systems in recreational vehicles and pleasure boats. The installation of a switch permits manual control of the pump. A generous flow of water is delivered through any of the Jabsco galley hand



Model 37205-0000

pumps or a standard faucet fixture with seals removed. No bypass plumbing required with this flow-through pump and does not affect use of hand pump fixture when power is not available.

### **DIMENSIONAL DRAWING**

inches (millimetres)

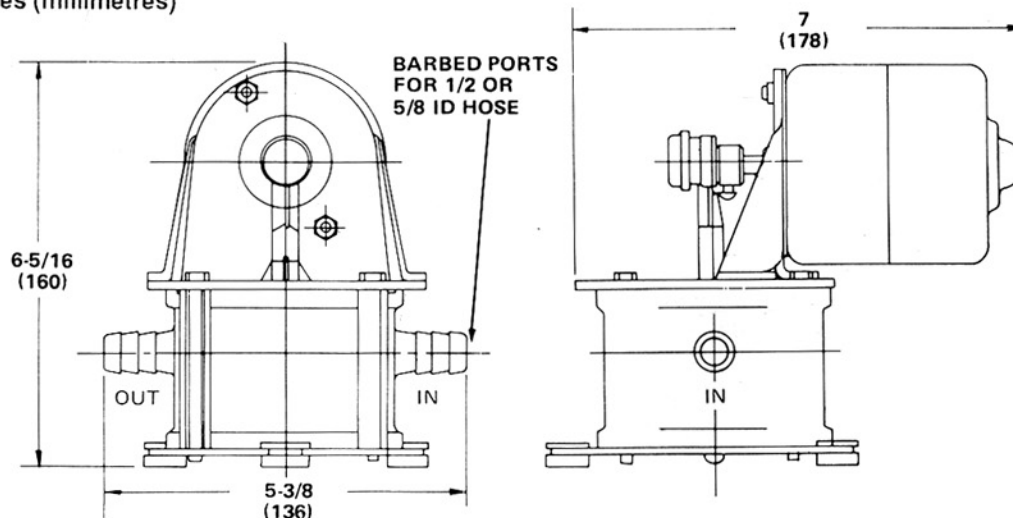

## INSTALLATION

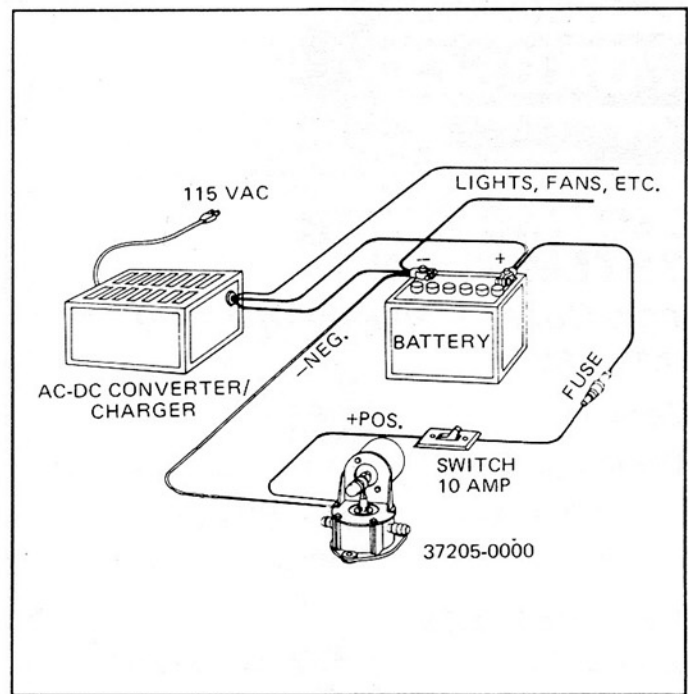
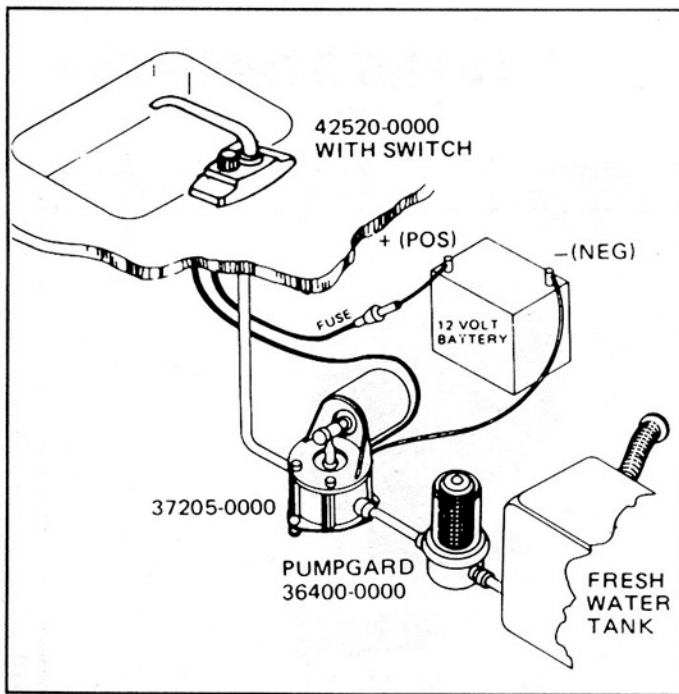

## MOUNTING

Jabsco diaphragm pumps are self-priming. They may be located above or below the fresh water tank. The pump is equipped with vibration dampening grommets that are most effective when the pump is mounted upright on a solid surface.

## PLUMBING

To minimize water pressure drop, use 3/8" tubing or larger. Valves, elbows, etc., used should be the same size as pipe or tubing. Fresh water tank must be vented. See plumbing diagram.

In the single outlet installation, pump delivers water through a standard household faucet WITH SEALS REMOVED. A Jabsco galley hand pump may be used in place of the faucet as a backup when power source is disconnected. Also Electric Faucet Model #42520-0000 may be used in place of faucet and switch.

Do not close off discharge when pump is operating; use the switch to control pump.

**SUCTION FILTER.** A Pumpgard Model 36400-0000 (strainer/filter) is recommended to be installed between the pump and fresh water tank. It helps prevent valve clogging caused by foreign material entering the pump.

**WATER PURIFIER.** Many water purifiers cause excessive restriction to flow, especially when element is in use for some time. If water purifiers must be used in the distribution line, provide a relief valve (set at 20 psi) for pressure bypass.

## WIRING

Pump should be wired in a circuit independent of all other electrical fixtures. Use stranded copper wire #16 AWG for a total positive (+) and negative (-) wire length of up to fifty feet and #14 AWG for lengths up to one hundred feet.

**MOTOR PROTECTION.** The pump wiring must include a fuse or equivalent protective device in the positive lead to protect against overcurrent draw.

**SWITCH.** An on-off switch or push-button with a minimum rating of 10 amps must be installed in the positive lead of the circuit to operate the pump.

## OPERATION

- Check level of water in tank. Be sure valves are open and strainers or aerators are clean
- Activate electric pump using your manual on-off switch or push button.
- If a Jabsco galley hand pump fixture is installed, the electric pump will deliver water with no adjustment to the hand pump needed.
- If power is not available to the pump, operate your Jabsco hand pump normally, with no adjustments to the electric pump.

## MAINTENANCE

**WINTER STORAGE.** The Jabsco pump, with its unique pulsation dampener, will withstand frozen water without damage. To prevent accidental plumbing damage, the entire water system must be made ready for winter storage. This requires complete draining, using the following directions and/or vehicle manufacturer's instructions:

1. Operate pump to empty water tank and intake lines. Run pump dry for 1 to 2 minutes before turning off.
2. Open all drains and blow air through city water entry (if used).
3. Disconnect discharge and intake hoses from pump. Start pump and allow to run until all water is expelled from unit. (Running dry will not harm the pump.)
4. Reconnect the hoses, close the drains and leave faucets open. The water distribution system is now winter protected.

An alternate method is to use **POTABLE WATER SYSTEM ANTI-FREEZE** solution. Follow directions from anti-freeze manufacturer.

**⚠ DANGER** DO NOT USE AUTOMOTIVE TYPE ANTI-FREEZE. IT IS POISONOUS. USE OF THIS TYPE ANTI-FREEZE WILL CAUSE SERIOUS INTERNAL INJURY OR DEATH.

## TROUBLESHOOTING

### PROBLEMS

### CAUSES

Pump operates but no water flows through faucet.

- Low water level in tank.
- Water lines are clogged.
- Kink in water hose.
- Air leak in suction line.
- Dirty or hard-to-open in-line check valve.
- Defective pump valve.
- Ice in line.

Pump operates roughly and has excessive noise and vibration.

- Intake line is restricted, kink in suction hose or fittings too small.
- Pump mounted on flimsy board.
- Deformed or ruptured pulsation dampener in pump.
- Loosened eccentric screw.
- Worn connecting rod bearing.

Pump fails to start.

- No voltage to pump.
- Blown fuse.
- Defective switch in electrical circuit.
- Defective motor.

**VALVES REPLACEMENT**

1. Turn off power to pump and drain water from system.
2. Remove four tie down screws.
3. Expose valves by lifting motor mount and attached diaphragm assembly from pump base. Remove valve retainer and lift valves from pockets. Clean all foreign materials from valves and seats.
4. Reinstall valves into same pockets, being sure rubber valve with small hole is UP on intake and rubber valve without the small hole is DOWN on discharge. **NOTICE:** Do not use valve with small hole in rubber on discharge side of pump.

**DIAPHRAGM AND CONNECTING ROD REPLACEMENT**

1. Turn off power to pump and drain water from system.
2. Remove four tie down screws, then lift motor mount and attached diaphragm assembly from pump base.
3. Expose diaphragm by removing two diaphragm retainer screws and detaching retainer. Disengage connecting rod by pulling off from eccentric.
4. Remove diaphragm screw to separate diaphragm and plates from connecting rod. Inspect diaphragm for cuts and ruptures. Check connecting rod assembly for breaks, cracks or excessive wear on rod and bearing. Original lubricant normally lasts lifetime of pump.
5. When reassembling, be sure to align diaphragm and connecting rod so that eccentric slips straight into connecting rod and diaphragm rests squarely on diaphragm retainer.

**PULSATION DAMPENER REPLACEMENT**

1. Turn off power to pump and drain water from system.
2. Remove four tie down screws and one bottom plate screw to separate bottom plate from base.
3. Pull out rubber pulsation dampener from base. Inspect for excessive deformation, ruptures and cuts.
4. When installing new dampener, place the three-rib (on bottom of dampener) section in discharge side of the base. Make sure the flange is well-seated to effect a proper water and air seal.

**MOTOR REPLACEMENT**

1. Turn off power to pump.
2. Disconnect motor wires.
3. Remove two motor nuts to separate motor.
4. Loosen set screw to remove eccentric from motor shaft.
5. When reassembling, check that Teflon\* washers are on eccentric shaft.

Teflon\* is a trademark of E. I. Du Pont de Nemours and Company.

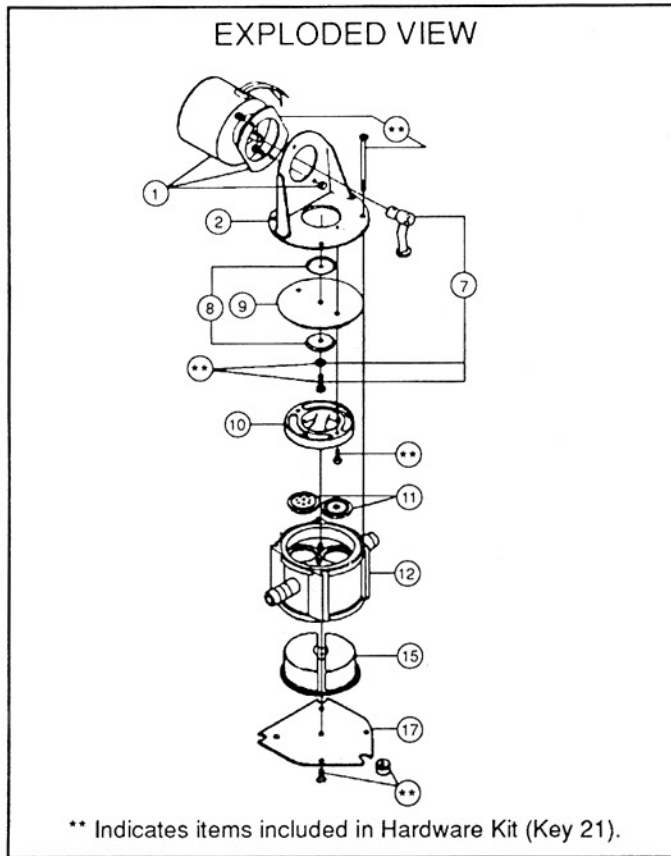

\*\* Indicates items included in Hardware Kit (Key 21).

**PARTS LIST**

**37205-Series**

Key	Part Description	Part Number	Qty
1	Motor Kit 12 Vdc	30202-0000	1
2	Motor Mount	35812-0000	1
7	Connecting Rod Assembly	30033-0000*	1
8	Diaphragm Plates	35479-0000	2
9	Diaphragm	37174-0000*	1
10	Retainer	35799-0000	1
11	Valve Set (Inlet & Outlet)	30130-0000*	1 Set
12	Base	35790-0000	1
15	Pulsation Dampener	37179-0000*	1
17	Bottom Plate	35798-0000	1
21	Hardware Kit	37168-0000	1 Set
	Service Kit*	30127-0000	1

\*Indicates Parts Contained in Service Kit.

THE PRODUCT DESCRIBED HEREIN IS SUBJECT TO THE JABSCO ONE YEAR LIMITED WARRANTY, WHICH IS AVAILABLE FOR YOUR INSPECTION UPON REQUEST.



A unit of ITT Fluid Technology Corporation  
 U.S.A. ITT Jabsco, 1485 Dale Way, P.O. Box 2158, Costa Mesa, CA 92628-2158  
 Tel: (714) 545-8251; Fax: (714) 957-0609

UNITED KINGDOM  
 ITT Jabsco  
 Hoddesdon, Herts.

CANADA  
 ITT Fluid Products  
 Guelph, Ontario

JAPAN  
 NHK Jabsco Co., LTD.  
 Yokohama, Kanagawa

GERMANY  
 Mintec, GmbH  
 Norderstedt