

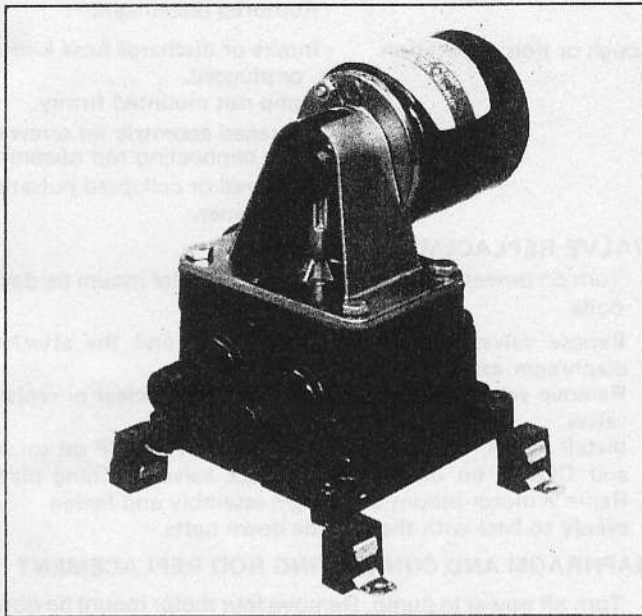

Model 36960-SERIES

Model 36960-SERIES



INSTALLATION

MOUNTING

Mount upright in a dry location (above highest bilge water level) on a solid surface. Selection of a dry, cool, ventilated location will generally extend pump life. Locate Pumpgard strainer in accessible spot in suction hose.

PLUMBING

For intake and discharge use 3/4" I.D. non-collapsible hose. Keep intake and discharge lines free of kinks and restrictions. To protect pump from debris, use the 3/4" in-line strainer, PAR Model 36200-0000 in the intake line from the bilge.

WIRING

Wire pump in a circuit independent of all other electrical fixtures. Use stranded copper wire. Install fuse in positive circuit. See table for recommended wire and fuse size. See diagram for wiring instructions. Use a 10 amp-rated switch (PAR 44960-Series). After installation, it is recommended that voltage be checked at the motor terminals with motor operating under full load. Voltage should not be less than 90% of rated motor voltage.

FEATURES

- Self-Priming
- Diaphragm Design Allows Dry Running
- Built-in Hydraulic Pulsation Dampener
- Pumpgard® Strainer Included with Pump
- Corrosion Resistant Materials Throughout for Sea Water Service
- Meets USCG Electrical Standards

SPECIFICATIONS

Open Flow:	4.0 GPM
Vert. Dry Suction Lift:	7 feet (2,1 m)
Ports:	3/4" Slip-on Hose
Weight:	7 Lbs (3,2 kgs)

STANDARD MODELS

Model	Voltage	Nominal Current	Fuse Size	
			Slow-Blow	Normal
36960-0000	12 VDC	6 AMP	6 1/4 AMP	8 AMP
36960-0010	24 VDC	5 AMP	5 AMP	7 AMP
36960-0020	32 VDC	2 AMP	2 AMP	3 AMP

WINTER STORAGE: When possible it is preferred that the complete pump be removed and stored in a warm dry place. If this is not possible the pump must be completely drained, hoses removed and pump run until all water is expelled.

WIRING

Wire Length Between Battery and Motor	Model 36960-0000 12 Volt	Model 36960-0010 24 Volt	Model 36960-0020 32 Volt
1 - 25 feet	12 AWG	14 AWG	16 AWG
25 - 50 feet	10 AWG	14 AWG	14 AWG

DIMENSIONAL DRAWING

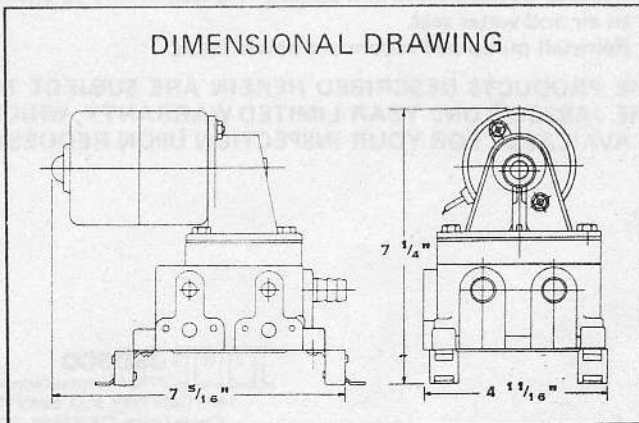

WIRING DIAGRAM FOR AUTOMATIC OPERATION

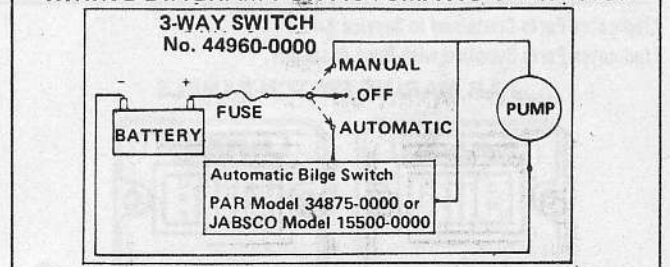

EXPLODED VIEW

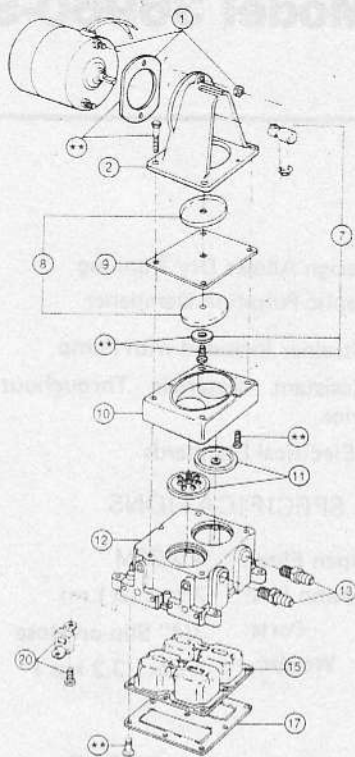

**Indicates items included in Hardware Kit (Key 21).

PARTS LIST

36960-Series

Key	Part Description	Part Number	Qty
1	Motor Kit 12 Volt D C.....	30202-0000	1
1	Motor Kit 24 Volt D C.....	30201-0010	
1	Motor Kit 32 Volt D C.....	30202-0020	
2	Motor Mount	35487-0000	1
7	Connecting Rod Kit.....	30040-0000*	1
8	Diaphragm Plate.....	35688-0000	2
9	Diaphragm	30015-0000*	1
10	Retainer	35455-0000	1
11	Valve Set (Inlet & Outlet).....	30003-0000*†	1 Set
12	Base Assembly†	35620-0000†	1
13	Ports (Inlet & Outlet).....	37175-0000†	1 Set
15	Pulsation Dampener	37178-0000*†	1
17	Bottom Plate	35686-0000†	1
20	Vibration Pad Kit.....	37180-0000†	1 Set
21	Hardware Kit.....	37167-0000	1 Set
	Service Kit*	30120-0000	

*Indicates Parts Contained in Service Kit.

†Indicates Parts Supplied with Base Assembly.

PAR MARINE SWITCH PANELS

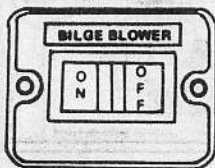

44960-0000
LIGHTED SWITCH
W/BOOT SPST

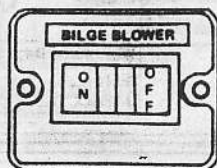

44960-0001
UNLIGHTED
SPST

SERVICE

TROUBLE SHOOTING

Problems

Causes

- | | |
|--|---|
| <p>Loss of suction to pump.</p> <p>Rough or noisy operation.</p> | <ul style="list-style-type: none"> - Air leak in suction line. - Bilge pickup not submerged. - Intake hose kinked or plugged. - Fouled intake or discharge valve. - Ruptured diaphragm. - Intake or discharge hose kinked or plugged. - Pump not mounted firmly. - Loosened eccentric set screw or worn connecting rod assembly. - Ruptured or collapsed pulsation dampener. |
|--|---|

VALVE REPLACEMENT

1. Turn off power to pump. Remove four motor mount tie down bolts.
2. Expose valves by lifting motor mount and the attached diaphragm assembly from pump base.
3. Remove valve retaining plate. Remove and clear or replace valves.
4. Install valves, making sure rubber flapper is UP on intake and DOWN on discharge. Replace valve retaining plate.
5. Replace motor-mount-diaphragm assembly and fasten evenly to base with the four tie down bolts.

DIAPHRAGM AND CONNECTING ROD REPLACEMENT

1. Turn off power to pump. Remove four motor mount tie down bolts.
2. Lift motor mount and the attached diaphragm assembly from pump base.
3. Remove two diaphragm retainer screws and the diaphragm retainer.
4. Pull connecting rod assembly and diaphragm from motor mount, then, unscrew bolt to separate diaphragm plates.
5. Loosely reassemble new diaphragm, diaphragm plates, washer and diaphragm bolt onto new connecting rod assembly.
6. Slide connecting rod on shaft. Ensure that eccentric is firmly seated on motor shaft and tighten set screw firmly against flat side of shaft.
7. Tighten connecting rod bolt while maintaining alignment of rod bearing eccentric. NOTICE: Avoid misalignment or twisting of rod on eccentric shaft or excessive bearing wear will result.

PULSATION DAMPENER REPLACEMENT

1. Disconnect power leads from pump and remove from mount.
2. Remove nine bottom plate screws and the bottom plate. Pull out and replace pulsation dampener.
3. Replace bottom plate and screws. Tighten evenly to ensure an air and water seal.
4. Reinstall pump and reconnect power leads.

THE PRODUCTS DESCRIBED HEREIN ARE SUBJECT TO THE JABSCO® ONE YEAR LIMITED WARRANTY, WHICH IS AVAILABLE FOR YOUR INSPECTION UPON REQUEST.

ITT Jabsco
ITT Fluid Technology Corporation
1485 Dale Way, P.O. Box 2158
Costa Mesa, CA 92628-2158
Telephone: (714) 545-8251