

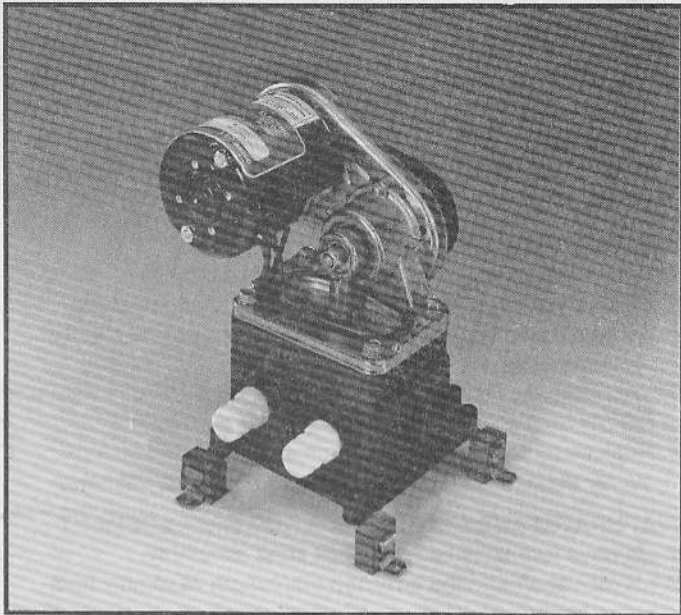

Model 36680-2 SERIES

Model 36680-2 SERIES



INSTALLATION

MOUNTING

Mount upright in a dry location (above highest bilge water level) on a solid surface. Selection of a dry cool ventilated location will generally extend pump life. Adjust belt tension for 1/4 inch play between pulleys.

PLUMBING

For intake and discharge use 3/4" ID non-collapsible hose. Keep intake and discharge lines free of kinks and restrictions. Use a 3/4" bilge strainer (PAR Model 35890-0000) or a 3/4" in-line strainer (PAR Model 36200-0000) in the intake line from the bilge to protect pump from debris. Use a 3/4" thru-hull fitting located above the waterline at all angles of heel or pitch.

WIRING

Wire pump in a circuit independent of all other electrical fixtures. Use stranded copper wire. Install fuse/breaker in positive lead. See table for recommended wire and fuse size. See diagram for wiring connections. Use a 10 amp-rated switch (PAR 44960-Series). After installation, it is recommended that voltage be checked at the motor terminals with motor operating under full load. Voltage should not be less than 90% of rated motor voltage.

ELECTRIC BILGE PUMP

FEATURES

- Self-Priming
- Diaphragm Design Allows Dry Running
- Quiet Operation
- Built-in Hydraulic Pulsation Dampener
- Permanently Lubricated Ball Bearings on Shaft and Connecting Rod
- Corrosion Resistant Materials Throughout for Sea Water Service
- NMMA Type Accepted

SPECIFICATIONS

	U.S. GPM	Liters/Min.	Imp. GPM
Open Flow:	5.5	21	4.5
Vert. Dry Suction Lift:	7 Feet (2,1m)		
Ports:	3/4" Slip-on Hose		
Weight:	8 lbs (3,6 kgs)		

STANDARD MODELS

Model	Voltage	Amperage (Nominal)
36680-2000	12 VDC	7
36680-2010	24 VDC	5
36680-2020	32 VDC	3

MAINTENANCE

WINTER STORAGE: When possible, it is preferred that the complete pump be removed and stored in a warm dry place. If this is not possible, the pump must be completely drained, hoses removed and pump run until all water is expelled.

WIRING AND FUSE SIZE

Wire Length Between Battery and Motor	Model 36680-2000 12 Volt	Model 36680-2010 24 Volt	Model 36680-2020 32 Volt
1-25 feet	12 AWG	14 AWG	16 AWG
25-50 feet	10 AWG	14 AWG	14 AWG
Fuse/Breaker*	10 AMP	6 AMP	4 AMP

*Customer supplied, not included with pump.

DIMENSIONAL DRAWING

INCHES (MILLIMETRES)

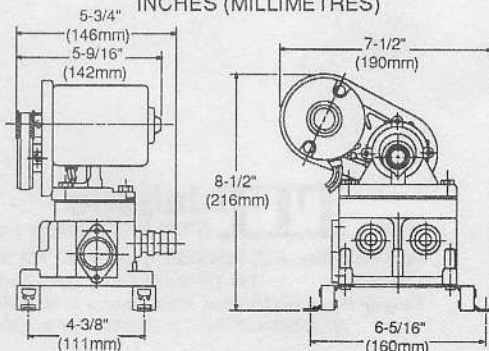

WIRING DIAGRAM FOR AUTOMATIC OPERATION

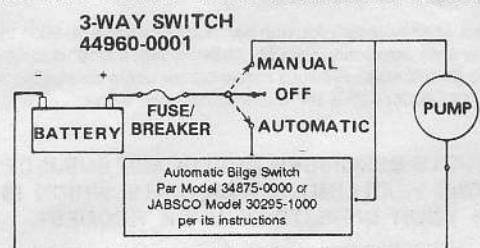

EXPLODED VIEW

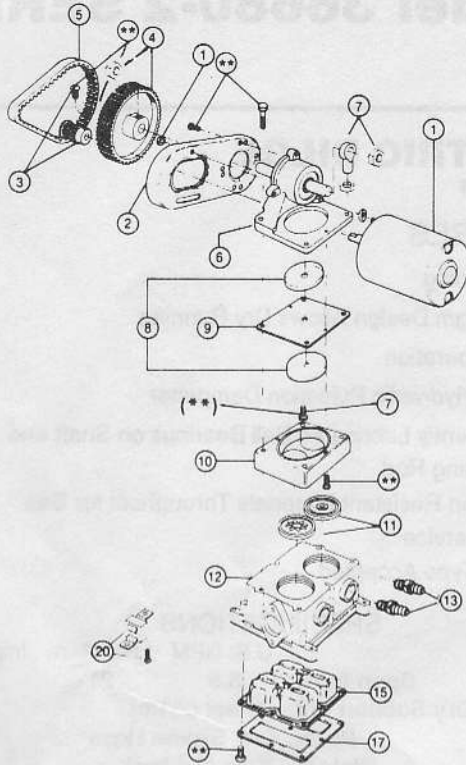

** Indicates items included in Hardware Kit (Key 21).

PART LIST

36680-Series

Key	Part Description	Part Number	Qty
1	Motor Kit 12 Vdc.	30200-0000	1
1	Motor Kit 24 Vdc.	30200-0010	1
1	Motor Kit 32 Vdc.	30200-0020	1
2	Motor Mount	34628-0000	1
3	Small Pulley	37169-0000	1
4	Large Pulley	37171-0001	1
5	Belt	30022-0000*	1
6	Jack Shaft Assembly	35690-0001 - See Note 1	1
7	Connecting Rod Kit	37173-0001 - See Note 1	1
8	Diaphragm Plate	35212-0000	2
9	Diaphragm	30016-0000*	1
10	Retainer	35173-0000	1
11	Valve Set (Inlet & Outlet)	30003-0000*†	1 Set
12	Base Assembly†	44114-1000	1
13	Ports (Inlet & Outlet) Barb	37175-0000†	1 Set
15	Pulsation Dampener	44127-1000	1
17	Bottom Plate	35686-0000†	1
20	Vibration Pad Kit	43990-0058†	1 Set
21	Hardware Kit	43990-0071	1 Set
	Service Kit*	43990-0062	

* Indicates Parts Contained in Service Kit.

† Indicates Parts Supplied with Base Assembly.

NOTE 1 - Jack shaft assembly kit, with part number ending in -0001 includes new style connecting rod (37173-0001) with a 5/16" diameter hole and two (2) locknuts. Previous model pumps use a connecting rod (37173-0000) with a 1/4" diameter hole and a bolt.

THE PRODUCTS DESCRIBED HEREIN ARE SUBJECT TO THE JABSCO® ONE YEAR LIMITED WARRANTY, WHICH IS AVAILABLE FOR YOUR INSPECTION UPON REQUEST.

TROUBLESHOOTING

Problems

Loss of suction to pump

SERVICE

Causes

- Air leak in suction line.
- Bilge pickup not submerged.
- Intake hose kinked or plugged.
- Fouled intake or discharge valve.
- Ruptured diaphragm.

Rough or noisy operation.

- Intake or discharge hose kinked or plugged.
- Pump not mounted firmly.
- Loosened eccentric screw.
- Ruptured or collapsed pulsation dampener.

NOTICE: Turn off power to pump before servicing. Failure to do so could cause leakage of water during repair.

VALVE REPLACEMENT

1. Remove four bolts securing jack shaft assembly.
2. Expose valves by lifting jack shaft and the attached diaphragm assembly from pump base. Remove and clean or replace valves.
3. Install valves, making sure rubber flapper is UP on intake and DOWN on discharge.
4. Replace motor-mount-diaphragm assembly and fasten evenly to base with the four tie down bolts and washers.

DIAPHRAGM AND CONNECTING ROD REPLACEMENT

1. Remove four bolts securing jack shaft assembly.
2. Lift jack shaft and the attached diaphragm assembly from pump base.
3. Remove two diaphragm retainer screws and the bottom diaphragm retainer.
4. Remove lock nut. Remove connecting rod and diaphragm from the top of diaphragm retainer, then unscrew bolt to separate diaphragm plates.
5. Check diaphragm for cuts and cracks. Check rod assembly bearing for excessive wear. Replace if badly worn.
6. Loosely reassemble diaphragm, diaphragm plates, connecting rod spacer and diaphragm bolt onto connecting rod. Using lock nut, firmly secure connecting rod to jack shaft. Secure diaphragm to upper diaphragm retainer with the bottom diaphragm retainer and two screws.
7. Tighten connecting rod bolt.
8. Replace motor-mount-diaphragm assembly and fasten evenly to base with the four tie down bolts and washers.

PULSATION DAMPENER REPLACEMENT

1. Disconnect power leads from pump and remove from mount.
2. Remove nine bottom plate screws and the bottom plate. Pull out and replace pulsation dampener.
3. Replace bottom plate and screws. Tighten evenly to ensure an air and water seal.
4. Reinstall pump and reconnect power leads.

ITT Jabsco

ITT Fluid Technology Corporation
 1485 Dale Way, P.O. Box 2158, Costa Mesa, CA 92628-2158
 Tel: (714) 545-8251; Fax: (714) 957-0609
 Bingley Road, Hoddesdon, Hertfordshire EN11 0BU England
 Tel: 0992-467191; Tlx: 263251 G; Fax: 0992-467132