

# PAR<sup>TM</sup>

## ELECTRIC BILGE PUMPS

# MODEL 36600-Series

### PRODUCT DATA

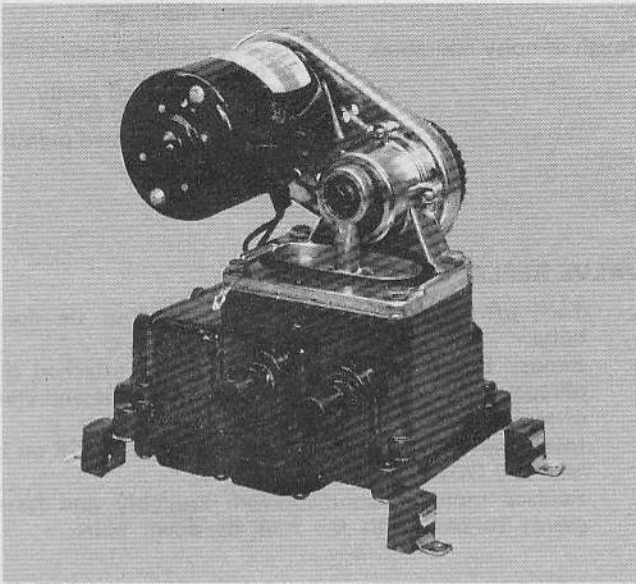

### INSTALLATION

#### MOUNTING

Mount upright in a dry location (above highest bilge water level) on a solid surface. Adjust belt tension for 1/4 inch play between pulleys.

#### PLUMBING

For intake and discharge use 3/4" I.D. non-collapsible hose. Keep intake and discharge lines free of kinks and restrictions. Use the 3/4" bilge in-line strainer (PAR Model 36200-0000) in the intake line from the bilge to protect pump from debris. Use a 3/4" thru-hull fitting (PAR Model 59431-0000) for discharge.

#### WIRING

Wire pump in a circuit independent of all other electrical fixtures. Use stranded copper wire. Install fuse in positive circuit. See table for recommended wire and fuse size. See diagram for wiring connections. Use a 10 amp-rated switch (JABSCO 3-way switch Model 96070-0110 or PAR 44960-0000). After installation, it is recommended that voltage be checked at the motor terminals with motor operating under full load and all other appliances in the circuit operating. Voltage should not be less than 90% of rated motor voltage.

### DIMENSIONAL DRAWING

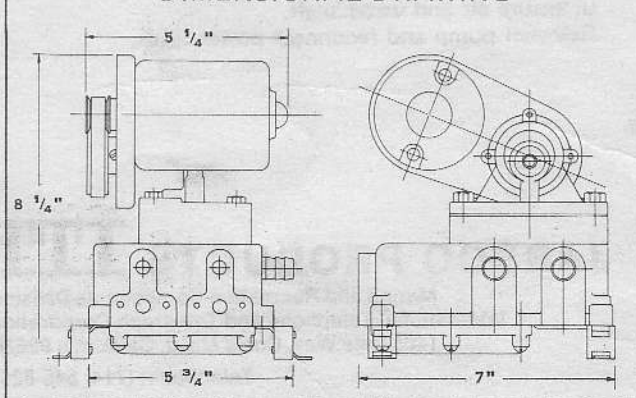

### FEATURES

- Self-Priming
- Diaphragm Design Allows Dry Running
- Quiet Operation
- Built-in Hydraulic Pulsation Dampeners
- Permanently Lubricated Ball Bearings on Shaft and Connecting Rod
- Large Vibration Absorbing Pads
- Corrosion Resistant Materials Throughout for Sea Water Service
- Meets USCG Electrical Standards

### SPECIFICATIONS

Open Flow:	8.0 GPM
Vert. Dry Suction Lift:	10 feet (3m)
Ports:	3/4" Slip-on Hose
Weight:	11 Lbs.

### STANDARD MODELS

Model	Voltage	Amperage Nominal
36600-0000	12 VDC	11.0
36600-0010	24 VDC	5.5
36600-0020	32 VDC	4.0

### MAINTENANCE

**WINTER STORAGE:** When possible it is preferred that the complete pump be removed and stored in a warm dry place. If this is not possible the pump must be completely drained, hoses removed and pump run until all water is expelled.

### WIRE AND FUSE SIZE

Wire Length Between Battery and Motor	Model 36600-0000 12 Volt	Model 36600-0010 24 Volt	Model 36600-0020 32 Volt
1-25 feet	12 AWG	14 AWG	16 AWG
25-50 feet	10 AWG	14 AWG	14 AWG
Fuse Size: Slo-Blo	10 AMP	6 1/2 AMP	4 AMP
	15 AMP	8 AMP	5 AMP

### WIRING DIAGRAM FOR AUTOMATIC OPERATION

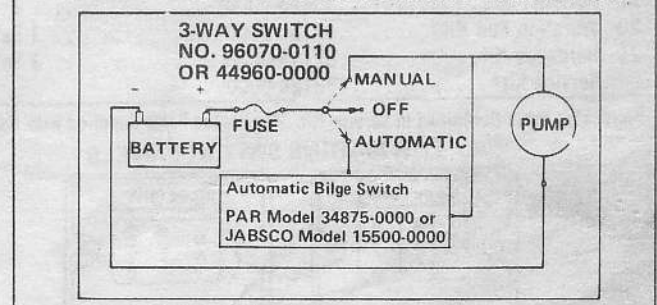

# JABSCO PRODUCTS **ITT**

Form 43000-0107 Rev. 12/79

MODEL 36600-SERIES

## EXPLODED VIEW

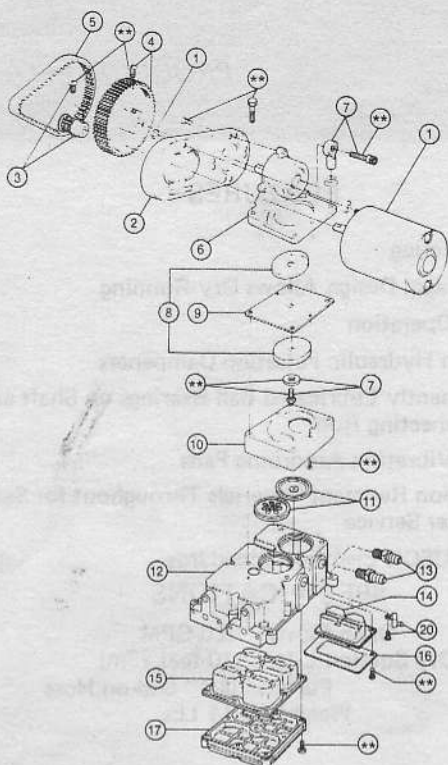

\*\*Indicates items included in Hardware Kit (Key 21).

## PARTS LIST

### 36600-Series

Key	Part Description	Part Number	Qty
1	Motor Kit 12 Volt D.C.	30200-0000	1
1	Motor Kit 24 Volt D.C.	30200-0010	1
1	Motor Kit 32 Volt D.C.	30200-0020	1
2	Motor Mount	34628-0000	1
3	Small Pulley	37169-0000	1
4	Large Pulley	37171-0000	1
5	Belt	30022-0000*	1
6	Jack Shaft Assembly	35691-0000	1
7	Connecting Rod Kit	37173-0000	1
8	Diaphragm Plate	35212-0000	2
9	Diaphragm	30016-0000*	1
10	Retainer	35173-0000	1
11	Valve Set (Inlet & Outlet)	30003-0000*†	1 Set
12	Base Assembly†	35630-1100	1
13	Ports (Inlet & Outlet)	37175-0000†	1
14	Small Pulsation Dampener	37177-0000*†	1
15	Pulsation Dampener	37178-0000*†	1
16	Small Bottom Plate	35628-0000†	1
17	Bottom Plate	35623-0000†	1
20	Vibration Pad Kit	37180-0000†	1 Set
21	Hardware Kit	37165-0000	1 Set
	Service Kit*	30124-0000	

\*Indicates Parts Contained in Service Kit. †Indicates Parts Supplied with Base Assembly.

### PAR MARINE SWITCH PANELS

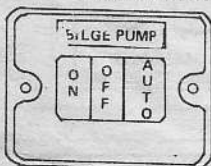

44960-0000  
LIGHTED SWITCH  
W/BOOT SPDT

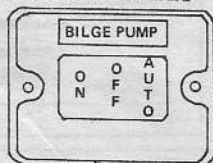

44960-0001  
UNLIT  
SPDT

## SERVICE

### TROUBLE SHOOTING

Problems	Causes
Loss of suction to pump.	- Air leak in suction line. - Bilge pickup not submerged. - Intake hose kinked or plugged. - Fouled intake or discharge valve. - Ruptured diaphragm.
Rough or noisy operation.	- Intake or discharge hose kinked or plugged. - Pump not mounted firmly. - Loosened eccentric screw. - Ruptured or collapsed pulsation dampener.

### VALVE REPLACEMENT

1. Turn off power to pump. Remove four tie down bolts.
2. Expose valves by lifting jack shaft and attached diaphragm assembly from pump base. Remove and clean or replace valves.
3. Install valves, making sure rubber flapper is UP on intake and DOWN on discharge.
4. Replace motor-mount-diaphragm assembly and fasten evenly to base with the four tie down bolts.

### DIAPHRAGM AND CONNECTING ROD REPLACEMENT

1. Turn off power to pump. Remove four tie down bolts.
2. Lift jack shaft and the attached diaphragm assembly from pump base.
3. Remove two diaphragm retainer screws and the diaphragm retainer.
4. Remove eccentric screw. Remove connecting rod and diaphragm from jack shaft, then unscrew bolt to separate diaphragm and plates.
5. Check diaphragm for cuts and cracks. Check rod assembly bearing for excessive wear. Replace if badly worn.
6. Loosely reassemble diaphragm, diaphragm plates, washer and diaphragm bolt onto connecting rod. Firmly secure connecting rod to jack shaft with the eccentric screw. Secure diaphragm to motor mount with the diaphragm retainer and two screws.
7. Tighten connecting rod bolt.

### PULSATION DAMPENERS REPLACEMENT

1. Disconnect power leads from pump and remove from mount.
2. Remove nine bottom cap screws and three bottom plate screws. Remove bottom cap and plate. Pull out and replace pulsation dampeners.
3. Replace bottom cap, plate and screws. Tighten evenly to ensure air and water seals.
4. Reinstall pump and reconnect power leads.

# JABSCO PRODUCTS ITT

Marine and Recreation Components Division  
International Telephone and Telegraph Corporation  
1485 Dale Way, Costa Mesa, California 92626  
Telephone: (714) 545-8251