

**PAR**<sup>®</sup>

# Model 34739-SERIES

Model 34739-SERIES

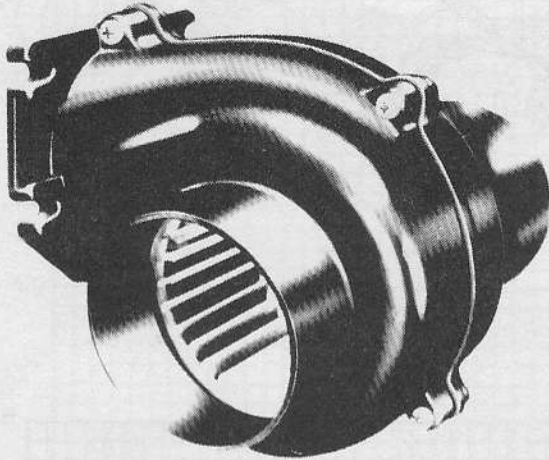

## INSTALLATION

**INSTALLATIONS MUST MEET APPLICABLE SECTIONS OF TITLE 33, PART 183; SUBPART K, USCG VENTILATION REGULATIONS.**

**MOUNTING:** Mount blower on flat bulkhead surface in highest part of compartment free from spray or deck wash. Cut 2-3/4" hole in bulkhead and secure blower with washers and No. 10 screws. (**NOTICE:** Tighten screws evenly to avoid flange damage). Use outlet collar No. 34856-0000 to connect ducting to discharge vent. Use a suitable discharge fitting so that static pressure of blower will not be affected by change in wind direction. Route inlet ducting with as few bends as possible to lower 1/3 of bilge compartment where vapors are likely to accumulate. Be sure ducting is positioned below top of engine stringers but not so low as to become submerged in bilge water. Locate pickup to take advantage of natural air flow direction. PAR flexible ducting No. 34959-0100 is easy to cut and install.

**NOTICE:** Blower should be mounted away from extreme heat (more than 130°F) to prevent distortion of blower wheel or housing.

For an exposed inlet, PAR ventilator intake screen No. 34764-0000 provides a safe and attractive protected inlet. **NOTE:** This blower may also be mounted with inlet through bulkhead, using intake collar No. 34943-0000.

PAR blowers are primarily intended for intermittent duty cycles such as evacuating fuel vapors from bilge areas. If desired, they also may be used for other general air circulation applications with longer duty cycles. However, when doing so, it should be noted that the maximum motor life is approximately 1000 hours. Therefore, the blower should only be used for applications if this length of service is acceptable.

**OPERATION:** See following warning placard statement:  
**"WARNING - GASOLINE VAPORS CAN EXPLODE. BEFORE STARTING ENGINE, OPERATE BLOWER FOR 4 MINUTES AND CHECK ENGINE COMPARTMENT BILGE FOR GASOLINE VAPORS. RUN BLOWER BELOW CRUISING SPEED. FAILURE TO DO SO MAY RESULT IN INJURY OR DEATH."**

THE "WARNING" PLACARD SUPPLIED WITH BLOWER MUST BE MOUNTED ADJACENT TO ENGINE IGNITION SWITCHES (ALL LOCATIONS) TO COMPLY WITH TITLE 33, PART 183; SUBPART K, USCG VENTILATION REGULATIONS.\*

\* Additional warning placards are available from factory by requesting form 43003-0418

## FLANGEMOUNT 3" BLOWER

### FEATURES

- Tough Reinforced Plastic Housing
- Mount To Any Flat Surface
- Slip-on Inlet Ducting Connection
- Efficient High Volume Air Flow
- Low Current Draw
- Corrosion-Resistant Materials Throughout
- N.M.M.A. Type Accepted
- Meets Requirements Of Title 33, Chapter I, Part 183; Subpart I, USCG Electrical Regulations

### SPECIFICATIONS

Model	Air Flow	Volts	Amps	Fuse Size	Weight Lbs.
34739-0010	150 CFM (4,2 m <sup>3</sup> /min.)	12DC	6.5	10A	5 (2,3 kg)
34739-0020	150 CFM (4,2 m <sup>3</sup> /min.)	24DC	3.3	5A	5 (2,3 kg)
34739-0030	150 CFM (4,2 m <sup>3</sup> /min.)	32DC	2.5	5A	5 (2,3 kg)
34739-0031	140 CFM (4,0 m <sup>3</sup> /min.)	115AC	0.8	1.25A 125V	5 (2,3 kg)

**WIRING FOR DC MODELS:** Use stranded copper wire. For lengths up to 25 feet (7,6m) from power source: Use 12 gauge wire for 12 Volt, 14 gauge wire for 24 Volt, and 16 gauge wire for 32 Volt models. Use larger wire for longer lengths. Use a 10 amp rated on-off switch in positive side of circuit (PAR Model 44960-0003). Circuit must be protected with a fuse. Suggested fuse sizes are listed in the specifications table.

**WIRING FOR AC MODEL:** Use 16 gauge stranded copper wire for lengths up to 100 feet from power source. Connect the grounded, unswitched conductor (white) to the white motor lead. Connect the undergrounded, switched conductor (black) to the black motor lead. This conductor should include, at the power source, a 1.25 amp 125 Volt fuse. The green motor lead must be connected to the AC circuit ground.

### INSTALLATION DRAWING

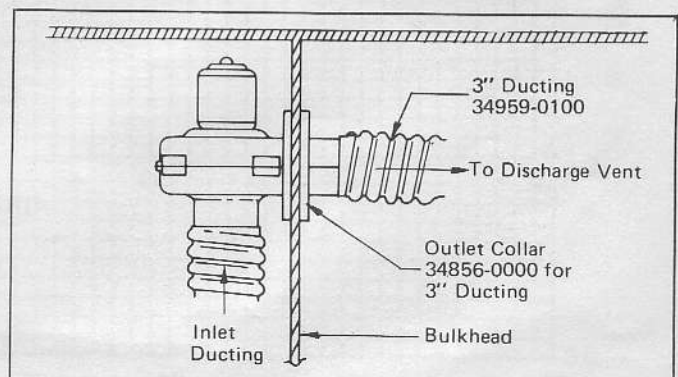

### PARTS LIST

Key	Part Description	34739-Series	Qty.
1	Motor Kit		1
	12 VDC	30200-0000	
	24 VDC	30200-0010	
	32 VDC	30200-0020	
	115 VAC	30200-0050	
2	Blower Housing	35774-0000	1
3	Blower Wheel	34742-0001	1
4	Blower Housing	35775-0000	1
5	Screw 8 x 5/8 SS	35508-0000	4
	Self Tapping Pan Head		

### PARTS VIEW

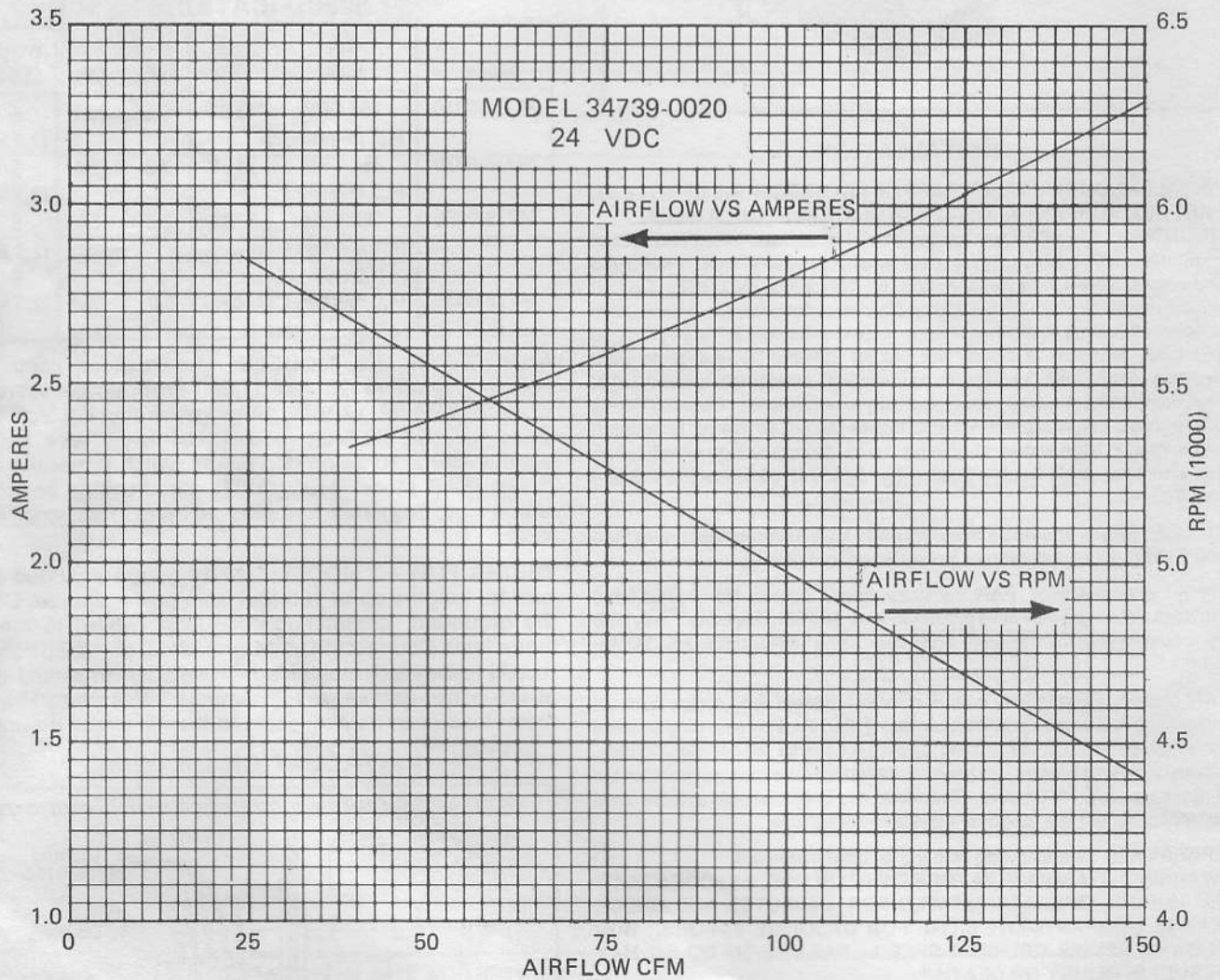
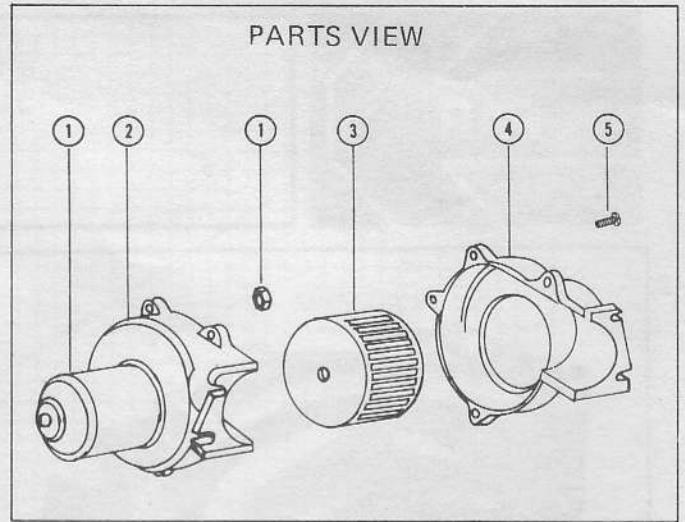

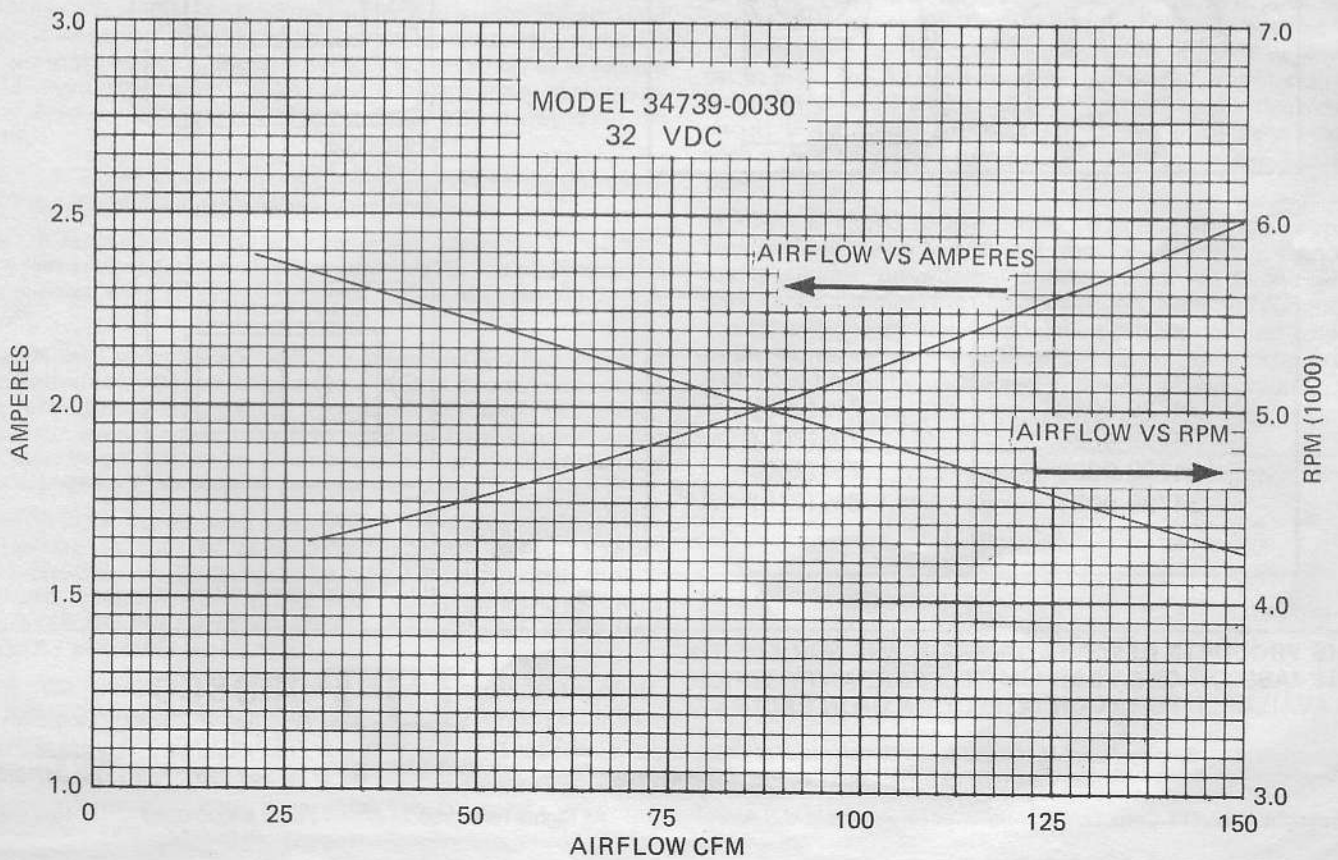
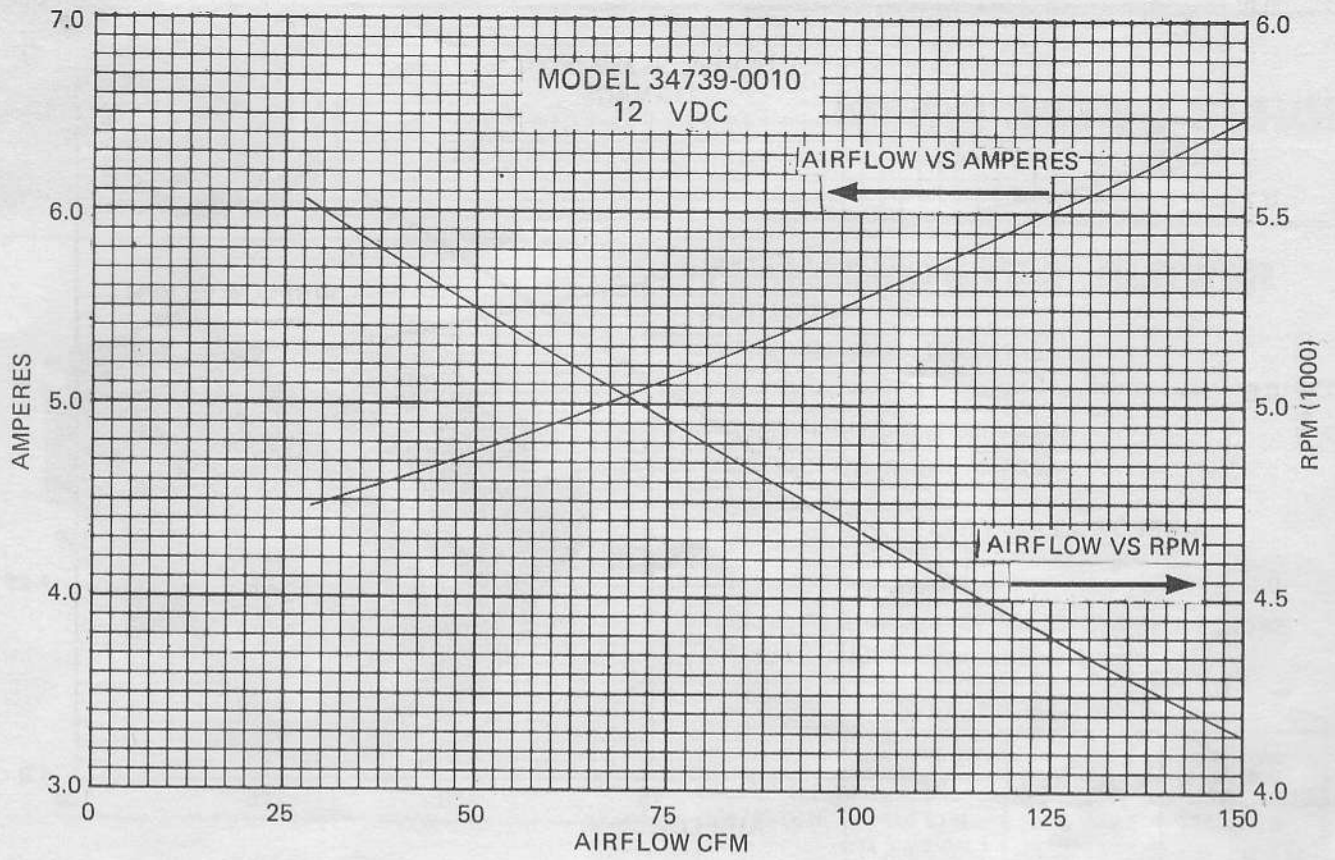

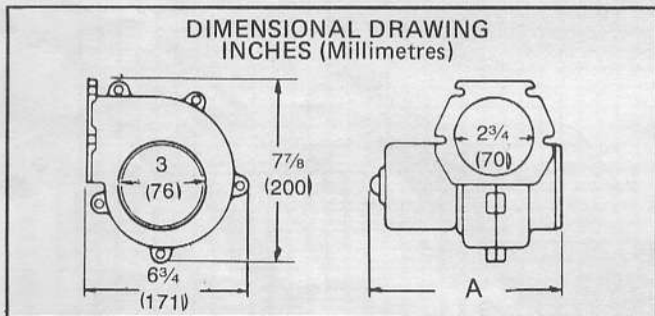
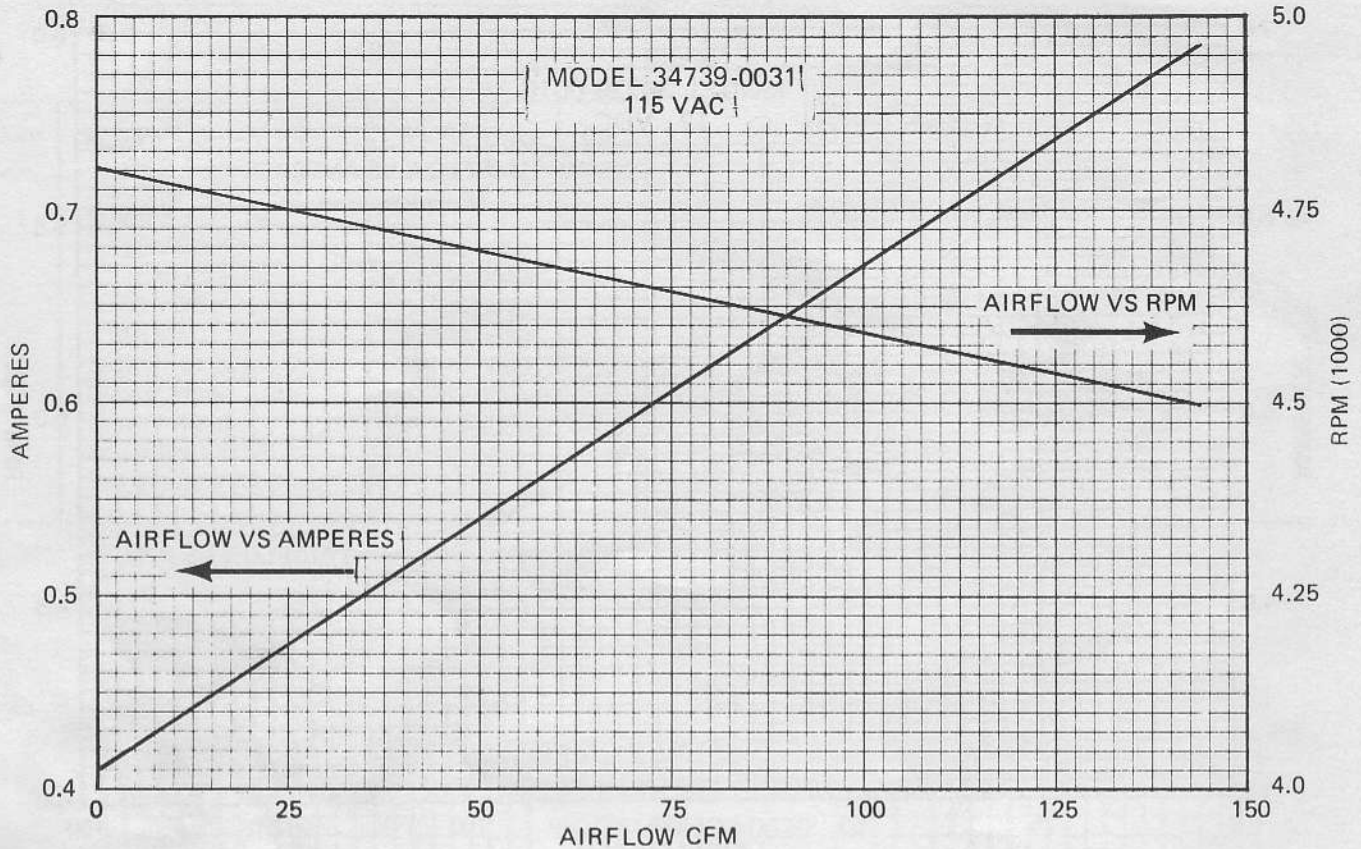

**PAR MARINE SWITCH PANELS**

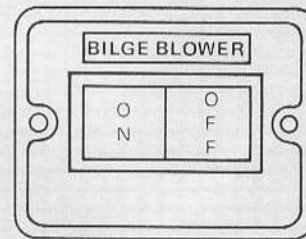

44960-0002  
LIGHTED SWITCH  
W/BOOT SPST  
(FOR DC BLOWERS ONLY)

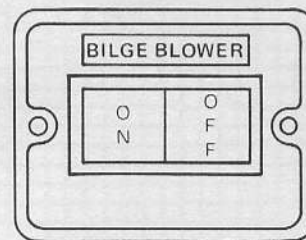

44960-0003  
UNLIGHTED  
SPST  
(FOR AC OR DC BLOWERS)

MODEL	DIMENSION A
34739-0010	7 7/8 (200)
34739-0020	7 7/8 (200)
34739-0030	7 7/8 (200)
34739-0031	8 3/8 (213)

THE PRODUCTS DESCRIBED HEREIN ARE SUBJECT TO THE JABSCO® ONE YEAR LIMITED WARRANTY, WHICH IS AVAILABLE FOR YOUR INSPECTION UPON REQUEST.

Bingley Road, Hoddesdon, Hertfordshire EN11 0BU, England  
Tel: 0992-467191; Tlx: 26351 G; Fax: 0992-467132

1485 Dale Way, P.O. Box 2158, Costa Mesa, Ca 92628-2158  
Tel: (714) 545-8251; Fax: (714) 957-0609

**ITT Jabsco**

ITT Fluid Technology Corporation